



Standard Single-Axis Linear Motor Stage **SSA**

Technical Information



Optimal Produce
Selection Tool



Catalog
Download



Linear Motor Stage

Automated transport / AOI application / Precision / Semiconductor

- With Iron Core
- Ironless Type
- Linear Turbo LMT
- Planar Servo Motor
- Air Bearing Platform
- X-Y Stage • Gantry Systems
- Single-Axis Linear Motor Stage



Linear Motor

Machine tool / Touch panel industry / Semiconductor industry / Laser manufacturing machine / Glass cutting machine

- Iron Core Linear Motor-LMSA, LMSA-Z, LMFA, LMFC, LMFP series
- Ironless Linear Motor-LMC, LMT series



Torque Motor & Direct Drive Motor

Machine Tools

- Torque Motor-TM-2/IM-2, TMRW series

Inspection / Testing Equipment / Robot

- Direct Drive Motor-DMS, DMY, DMN, DMT series



AC Servo Motor & Drive

Semiconductor / Packaging machine / SMT / Food industry / LCD

- Drives-D1, D2T/D2T-LM, E1
- Motors-50W-2000W



Linear Actuator

Hospital bed / Automatic window / Home care facility / Riveting / Press-fitting / Surface checks / Bending

- Servo Actuator-LAA series
- LAM series
- LAS series
- LAN series
- LAC series



Positioning Measurement System

Cutting machines / Traditional gantry milling machines / Programmable drilling machines

- High Resolution
- Signal Translator
- High-precision Enclosed
- High Efficiency Counter



Multi-Axis Robot

Pick-and-place / Assembly / Array and packaging / Semiconductor / Electro-Optical industry / Automotive industry / Food industry

- Articulated Robot
- Delta Robot
- SCARA Robot
- Wafer Robot
- Electric Gripper
- Integrated Electric Gripper
- Rotary Joint



Single-Axis Robot

Precision / Semiconductor / Medical / FPD

- KK, SK
- KS, KA
- KU, KE, KC



Torque Motor & Rotary Table

Medical / Automotive industry / Machine tools / Machinery industry

- RAB Series
- RAS Series
- RCV Series
- RCH Series



Ballscrew

Precision Ground / Rolled

- Super S series
- Super T series
- Mini Roller
- Ecological & Economical lubrication Module E2
- Rotating Nut (R1)
- Energy-Saving & Thermal-Controlling (C1)
- Heavy Load Series (RD)
- Ball Spline

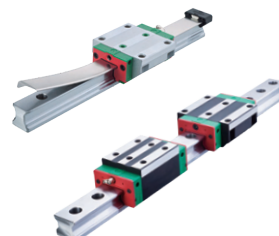

Linear Guideway

Automation / Semiconductor / Medical

- Ball Type--HG, EG, WE, MG, CG
- Quiet Type--QH, QE, QW, QR
- Other--RG, E2, PG, SE, RC

Contents

SSA (Single-Axis Linear Motor Stage)

1 Advantages	04
2 Selections and Features	06
3 Product Line	08
4 Product Specifications	12
5 08 Series	14
6 10 Series	22
7 13 Series	30
8 18 Series	42
9 20 Series	48

Drive and Accessories

1 Advantages and Selections	55
2 E1 Drive	56
3 D1 Drive	62
4 D2T-LM Drive	68
5 Pin Assignments	72
6 Encoder Extension Cable	74

SSA

Short lead time and high accuracy

Standard Single-Axis linear motor stage

Description of Internal Structure

Iron-core Motors

- High force density linear motors maximize thrust in a limited space, suitable for high dynamic response.
- High-quality magnet has the advantages of high temperature resistance and excellent stability.
- With the velocity ripple compensation function of the E1 drive, velocity ripple reaches as low as 1% (10mm/s).

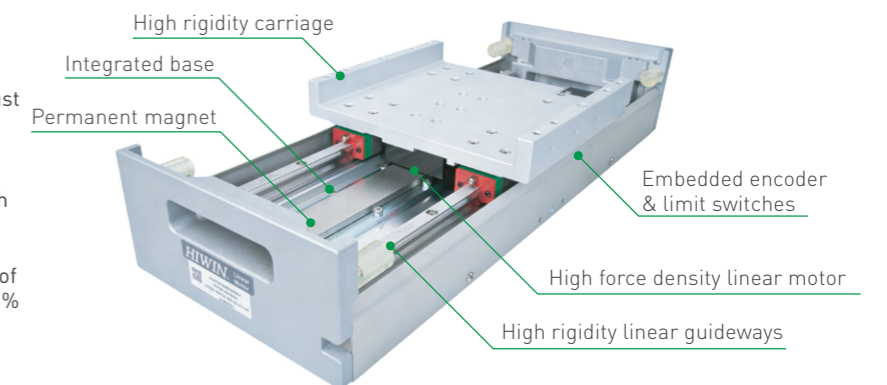

Ironless Motors

- The ironless linear motor has low inertia and is suitable for slow scanning/inspection applications.
- Utilizing a double row of high quality magnets increases the strength of magnetic field.

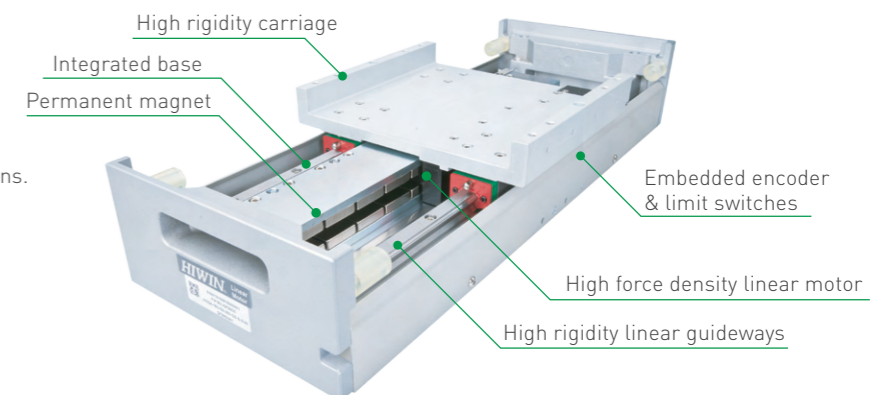

SSA Series

HIWIN MIKROSYSTEM Single-Axis Linear Motor Stage Features

- High force density design paired with high speed response (3.2kHz) which maximizes linear motor performance.
- Embedded encoders and limit switches avoid environmental interference.
- Error mapping before shipment when purchased with Hiwin drives.



Max. Acceleration 10G



Max. Velocity 5m/s

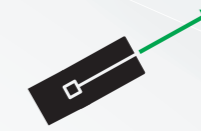



Stroke 100~2700mm

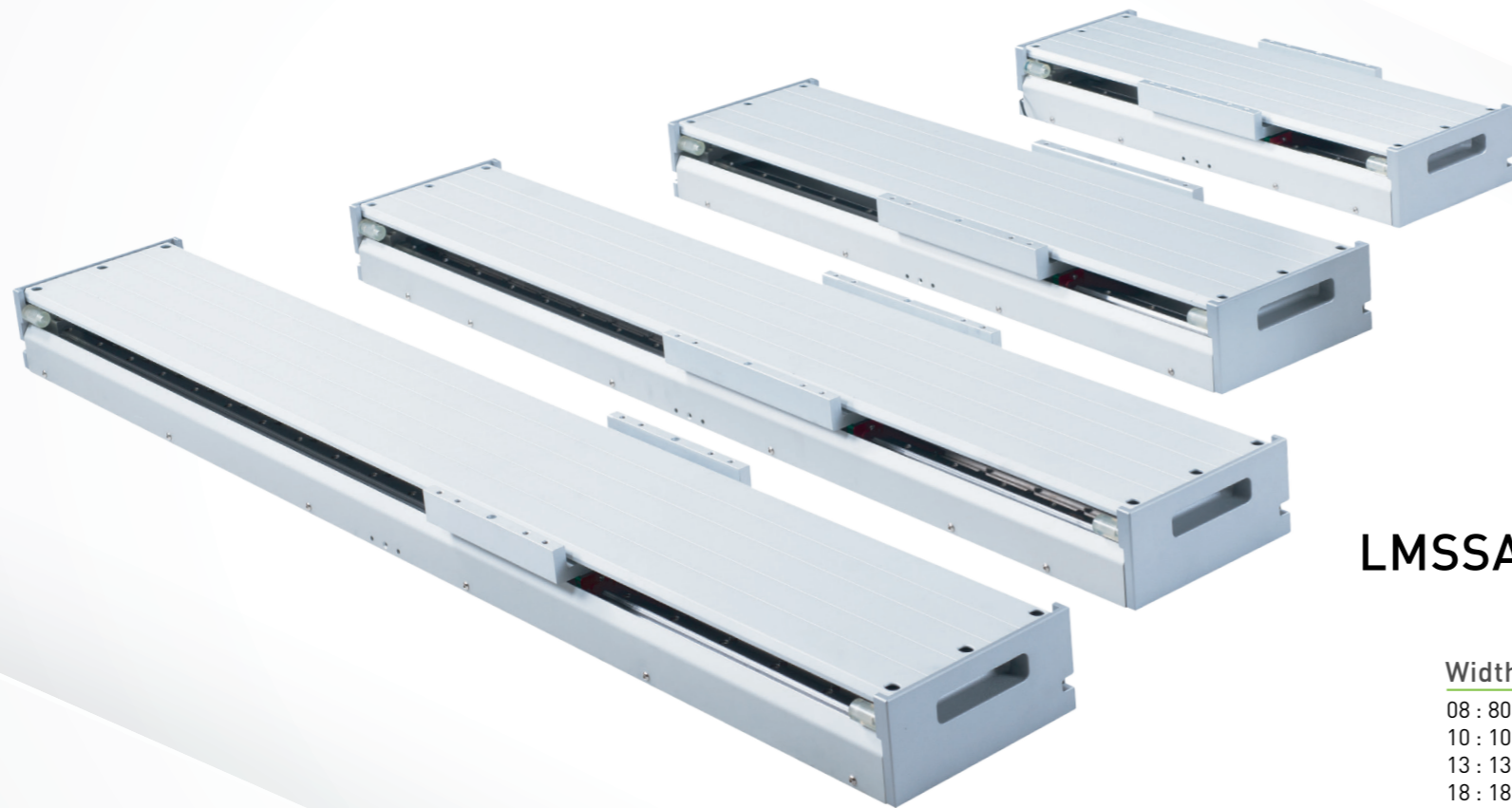

Accuracy ±1µm



Cover Type

S	M
General Application (normal environment)	Laser cutting and 3D printing (harsh environment)
	

LMSSA-13 S 100-1-800-G5.3A-S-S-A0000

Width(mm)

08 : 80
10 : 100
13 : 135
18 : 185
20 : 206

Motor type

S : Iron core
C : Ironless

Rated force level^(*)

050, 100, 200, 300, 500, 700

Number of forcers

1 : Single forcer
2 : Dual forcers

Stroke(mm)

100~2700
(Available in 50 mm increment up to 1300mm and 100 mm increments up to 2700mm)

Encoder type^(*)

A : Analog optical
D : Analog magnetic
E : Digital 1µm resolution magnetic encoder
G : Digital 1µm resolution optical encoder
K : Digital 0.1µm resolution optical encoder
H : Hall encoder (Analog)
P : Absolute optical encoder 0.5µm (BiSS-C)

Custom code

0000 : Standard

Voltage

A : Standard
B : High voltage
(For SSA-18,20)

Color

S : Aluminum color
(For SSA-18,20)
B : Black

Cover

S : S cover
M : M cover

Limit switch

A : NPN,NC
B : PNP,NC

Cable length^(*)

3.3 : Power : 3m/ Encoder : 3m (For SSA-08,10)
5.3 : Power : 5m/ Encoder : 3m
7.3 : Power : 7m/ Encoder : 3m (For SSA-13,18,20)

Note:

1. Please refer Product Dimension and Specification on p.8~p.11.
2. Encoder extension cable is sold separately (see p.58).
3. The length of cable is measured from the motor/encoder.
For the length from the forcer plate will be 0.5m shorter, eg.
Cable length 3m -> 2.5m; 5m -> 4.5m; 7m -> 6.5m

Quick selection program

01 Select motor type

Use LMSSA selection program immediately!

03 Review report and drawing

02 Set conditions

Belt driven versus linear motor driven





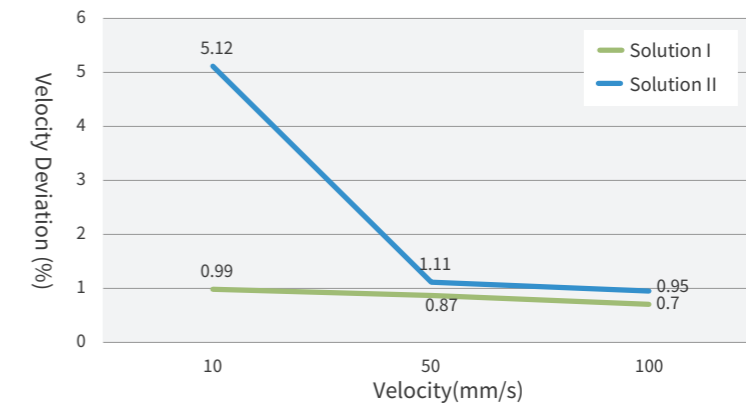

Structure	Belt	Linear Motor
Efficiency	Mechanical transmission loss	Direct drive without transmission loss
Velocity	≤ 3 m/s	≤ 5m/s
Acceleration	≤ 3G	≤ 10G
Positioning Accuracy (Stroke 300mm)	≥ 0.05mm	≥ 0.001mm
Service Life	≤ 2 years	≥ 10 years
Noise	≥ 80 dB	≤ 75dB
Speed Stability (20mm/s)	Deviation ±8%	Deviation ≤ ±1%
Friction	Mechanical friction	Mechanical friction on guideway only
Stroke	≤ 4m	Unlimited
Quantity of Sliders	1	Unlimited
Assembly Method	Straightness and concentricity need to be adjusted	Only need to pay attention to the air gap betweenforcer and stator.
Dimension	Extended length depends on servo motor dimension	Motor is already in the effective stroke.



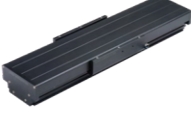



Velocity Ripple Comparison Chart



	Motor	Drive	Solution
Solution I	Iron core Linear Motor	E1 Series	Velocity Ripple Compensation
Solution II	Ironless Linear Motor	D1 Series	

Note:
 1. All solutions are tested with optical encoders.
 2. Optical encoders are recommended for low ripple applications.

Model No.	Rated force level	Appearance	Base Width (mm)	Continuous Force (N)			Motor Type	Repeatability (μm)	Max. Velocity (m/s)	Acceleration(G)	Load Capacity (kg)
LMSSA-08S	050		80	52				Repeatability ± 1 μm A: Analog optical K: Digital optical 0.1 μm	5	5	10
	100			104					5	5	
LMSSA-10S	100		100	103				Repeatability ± 2 μm G: Digital optical 1 μm	4.4	7	10
	200			205					4.4	10	
LMSSA-13S	100		135	103			Iron core	Repeatability ± 3 μm D: Analog magnetic E: Digital magnetic 1 μm	4.4	7	50
	200			205					4.4	10	
	300			308					4.4	10	
LMSSA-18S	100		185	103				Repeatability ± 1 μm A: Analog optical K: Digital optical 0.1 μm P: Absolute optical 0.5 μm	4.4	7	50
	200			205					4.4	10	
	300			308					4.4	10	
LMSSA-18C	100			75			Ironless	Repeatability ± 2 μm G: Digital optical 1 μm	5	8	50
	200			150					5	10	
LMSSA-20S	300		206	362			Iron core	Repeatability ± 3 μm D: Analog magnetic E: Digital magnetic 1 μm	2.2	10	50
	500			544					2.2	10	
	700			725					2.3	10	
LMSSA-20C	100			91			Ironless	Repeatability ± 7.5 μm H: Hall encoder	5	6.7	50
	200			145					2.8	7.6	

Model No.	Rated force level	Appearance	Cover	Color	Stroke (mm)			Standard Cable Length (M)	Features	Drives	Reference Page	
LMSSA-08S	050		M type ----- S type	Black	Single forcer : 100~1400 Dual forcers : 100~1200			Power 3M Encoder 3M ----- Power 5M Encoder 3M	<ul style="list-style-type: none"> The slimmest model among the whole series products. (80mm) Seal protection. 	D2T-400W D1-36 E1-400W	P.14	
	100				Single forcer : 100~1300 Dual forcers : 100~1000					D2T-1kW D1-36 E1-1kW	P.18	
LMSSA-10S	100				Single forcer : 100~1400 Dual forcers : 100~1200				Single forcer : 100~1300 Dual forcers : 100~1000	<ul style="list-style-type: none"> Smallest width of 100mm among all models with equivalent continuous force (205N). Seal protection. 	D2T-400W D1-36 E1-400W	P.22
	200				Single forcer : 100~1300 Dual forcers : 100~1000						D2T-1kW D1-36 E1-1kW	P.26
LMSSA-13S	100				Single forcer : 100~2700 Dual forcers : 100~2500				Single forcer : 100~2500 Dual forcers : 100~2100	<ul style="list-style-type: none"> Smallest width of 135mm among all models with 2 meters stroke. Seal protection. 	D2T-400W D1-36 E1-400W	P.30
	200				Single forcer : 100~2600 Dual forcers : 100~2300						D2T-1kW D1-36 E1-1kW	P.34
	300			Single forcer : 100~2500 Dual forcers : 100~2100	D1-36 E1-1.2kW			P.38				
LMSSA-18S	100			Single forcer : 100~2700 Dual forcers : 100~2400	Single forcer : 100~2500 Dual forcers : 100~2000			<ul style="list-style-type: none"> Suitable to be used as lower axis in stack applications. 2 colors available (Aluminum Clear & Black). 	D2T-400W D1-36 E1-400W	P.42		
	200			Single forcer : 100~2600 Dual forcers : 100~2300					D2T-1kW D1-36 E1-1kW	P.44		
	300			Single forcer : 100~2500 Dual forcers : 100~2000					D1-36 E1-1.2kW	P.46		
LMSSA-18C	100		Single forcer : 100~2700 Dual forcers : 100~2400	Single forcer : 100~2500 Dual forcers : 100~2000	<ul style="list-style-type: none"> Suitable to be used as lower axis in stack applications. Low velocity ripple even at low velocity (1% @ 10mm/s). 2 colors available (Aluminum Clear & Black). 	D2T-1kW D1-36 E1-1kW	P.42					
	200		Single forcer : 100~2500 Dual forcers : 100~2000			D2T-1kW D1-36 E1-1kW	P.46					
LMSSA-20S	300		Single forcer : 100~2600 Dual forcers : 100~2300	Single forcer : 100~2400 Dual forcers : 100~1800	<ul style="list-style-type: none"> Model with biggest force among the whole series products (continuous force 725N). High rigidity. Fast point to point movement (acceleration 10G) Suitable to be used as lower axis in stack applications. 2 colors available (Aluminum Clear & Black). 	D2T-1kW D1-36 E1-1kW	P.48					
	500		Single forcer : 100~2500 Dual forcers : 100~2000			D1-36 E1-1.2kW	P.50					
	700		Single forcer : 100~2400 Dual forcers : 100~1800			D1-36 E1-1.2kW	P.52					
LMSSA-20C	100		Single forcer : 100~2600 Dual forcers : 100~2300	Single forcer : 100~2500 Dual forcers : 100~2000	<ul style="list-style-type: none"> High rigidity. Low velocity ripple even at low velocity (1% @ 10mm/s). Suitable to be used as lower axis in stack applications. 2 colors available (Aluminum Clear & Black). 	D2T-400W D1-36 E1-400W	P.48					
	200		Single forcer : 100~2500 Dual forcers : 100~2000			D2T-400W D1-36 E1-400W	P.50					

Product Specification



		SSA-08 Series		SSA-10 Series		SSA-13 Series		
Model		08S050	08S100	10S100	10S200	13S100	13S200	13S300
Dimension	Linear Motor Type	Iron core						
	Carriage Length (mm)	160	260	160	260	160	260	360
	Carriage Width (mm)	144		164		198		
	Base Width (mm)	80		100		135		
	Total Height (mm)	78		78		98		
Spec.	Continuous Force (N)	52	104	103	205	103	205	308
	Peak Force (N)	112	224	289	579	289	579	868
	Stroke (mm)	100 ~ 1300mm (50mm increments) ; 1300 ~ 2700mm (100mm increments)						
	Encoder Resolution	Analog optical 0.1µm / Digital optical 1µm / Digital optical 0.1µm / Digital magnetic 1µm Analog magnetic 1µm						
	Repeatability	Table 1						
	Accuracy	Table 1						
	Horizontal Straightness					±8µm /300 mm (stroke below 1200mm) ※Note 2		
	Vertical Straightness					±8µm /300 mm (stroke below 1200mm) ※Note 2		
	Max. Velocity (m/s) Note 5, Note 6	5	5	4.4	4.4	4.4	4.4	4.4
	Max. Acceleration (G) Note 5	5	5	7	10	7	10	10
Moving Mass (kg)	1.8	3	2.1	3.4	3.4	5.2	7.5	

		SSA-18 Series					SSA-20 Series				
Model		18S100	18S200	18S300	18C100	18C200	20S300	20S500	20S700	20C100	20C200
Dimension	Linear Motor Type	Iron core			Ironless		Iron core			Ironless	
	Carriage Length (mm)	180	240	370	180	370	240	370	470	240	370
	Carriage Width (mm)	203					229				
	Base Width (mm)	185					206				
	Total Height (mm)	88.7/108.7					91.7/111.7				
Spec.	Continuous Force (N)	103	205	308	75	150	362	544	725	91	145
	Peak Force (N)	289	579	868	300	600	1023	1535	2048	364	580
	Stroke (mm)	100 ~ 1300mm (50mm increments) ; 1300 ~ 2700mm (100mm increments)									
	Encoder Resolution	Analog optical 0.1µm / Digital optical 1µm / Digital optical 0.1µm / Digital magnetic 1µm Analog magnetic 1µm / Absolute optical 0.5µm / Hall encoder 1µm									
	Repeatability	Table 1									
	Accuracy	Table 1									
	Horizontal Straightness	±8µm /300 mm (stroke below 1200mm) Note 2									
	Vertical Straightness	±8µm /300 mm (stroke below 1200mm) Note 2									
	Max. Velocity (m/s) Note 3, Note 4	4.4	4.4	4.4	5	5	2.2	2.2	2.3	5	2.8
	Max. Acceleration (G) Note 3	7	10	10	8	10	10	10	10	6.7	7.6
Moving Mass (kg)	3.1	4.4	6.2	3	5	6.4	8.3	11	4.2	6	

Table 1. Encoder Repeatability and Accuracy

Encoder	Repeatability (µm)	Accuracy (mm) Note 5
Analog optical 0.1µm	±1	±2
Digital optical 1µm	±2	±4
Digital optical 0.1µm	±1	±2
Analog magnetic 1µm	±3	±6
Digital magnetic 1µm	±3	±6
Absolute optical 0.5µm	±1	±2
Hall encoder 1µm	±7.5	-

Note:

1. Measurement is performed on granite platform according to HIWIN solution.
2. Horizontal and vertical straightness can be applied only in single forcer axis.
3. Max. velocity will be determined by stroke, payload, encoder resolution etc.
4. With digital 0.1µm resolution optical encoder, the max. velocity is 1.5m/s.
5. Error compensation table is provided if HIWIN drive is not included.

Schematic diagram of offset load capacity

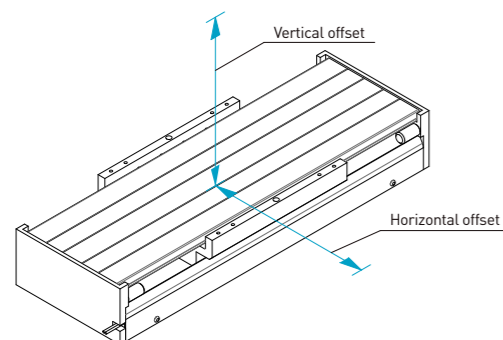

Note:

1. For the load capability, refer to the "Offset Load Capacity Curve" on the page of each specification.
2. It is recommended that the speed should not exceed 2m/s for vertical application.

SSA-08 Series Single Forcer

SSA-08S050
S cover Stroke 100~1400

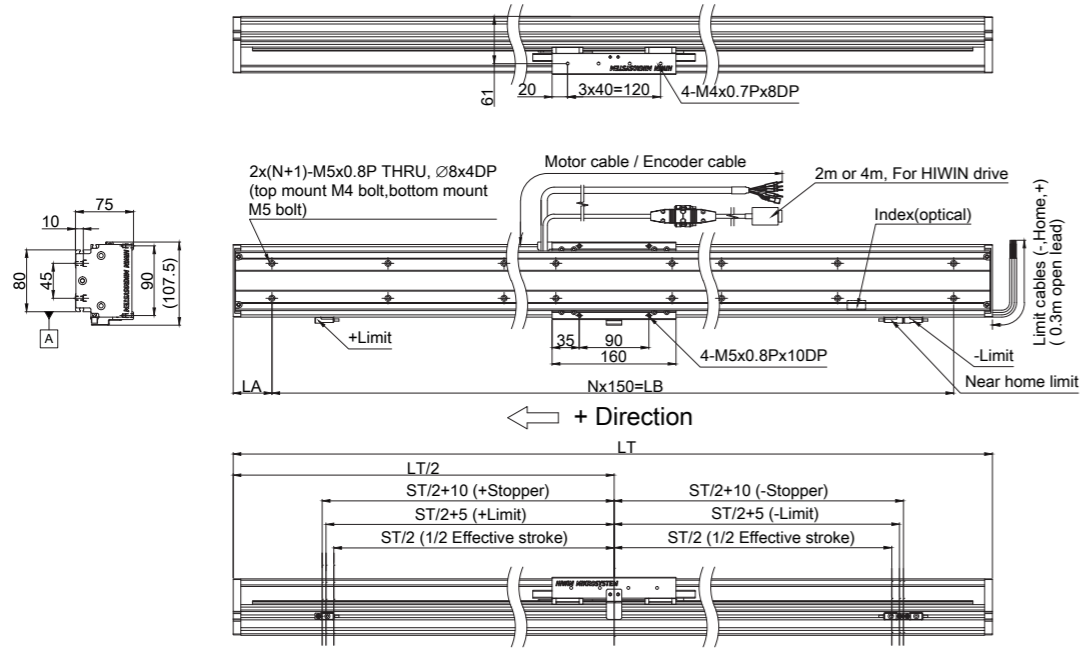

SSA-08 Series Dual Forcers

SSA-08S050
S cover Stroke 100~1200

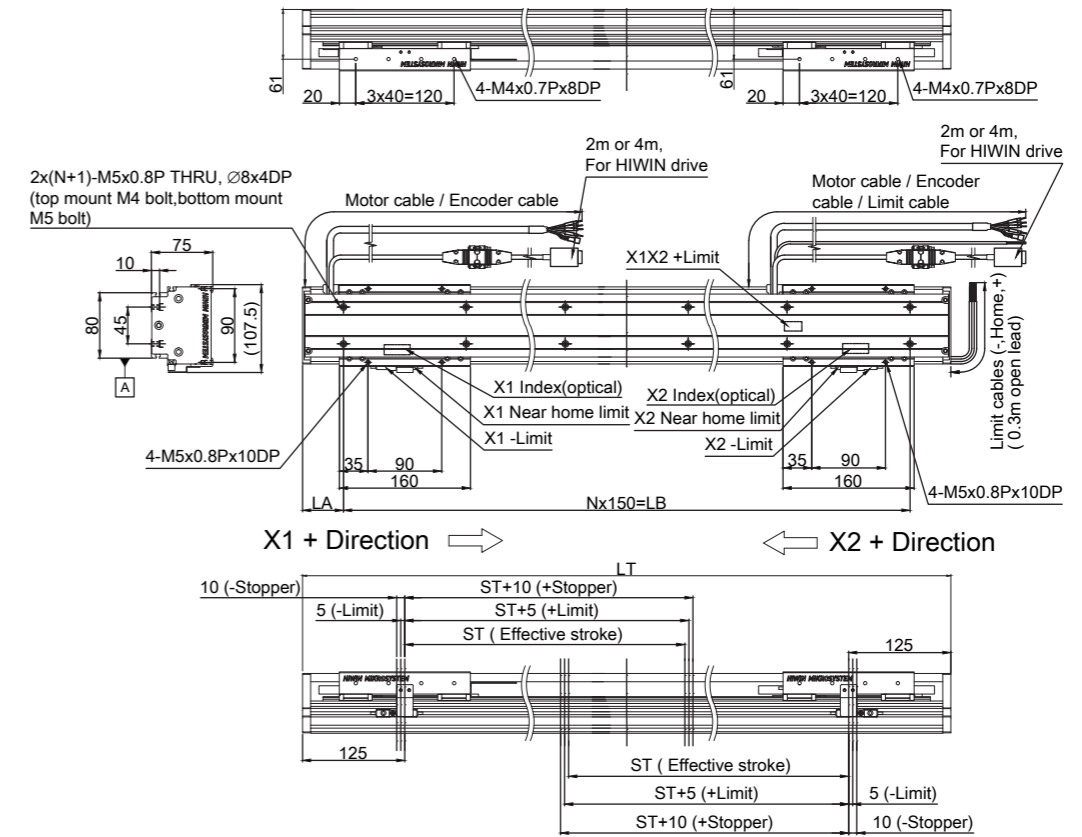

08S050																			
Specification / Effective Stroke	100	150	200	250	300	350	400	450	500	550	600	650	700	750	800	850	900	950	1000
LT	350	400	450	500	550	600	650	700	750	800	850	900	950	1000	1050	1100	1150	1200	1250
N	2	2	2	3	3	3	4	4	4	5	5	5	6	6	6	7	7	7	8
LA	25	50	75	25	50	75	25	50	75	25	50	75	25	50	75	25	50	75	25
LB	300	300	300	450	450	450	600	600	600	750	750	750	900	900	900	1050	1050	1050	1200
Weight	6.3	6.8	7.2	7.6	8.0	8.5	8.8	9.2	9.6	10.0	10.5	10.9	11.2	11.6	12.1	12.5	12.9	13.3	13.6

08S050							
Specification / Effective Stroke	1050	1100	1150	1200	1250	1300	1400
LT	1300	1350	1400	1450	1500	1550	1650
N	8	8	9	9	9	10	10
LA	50	75	25	50	75	25	75
LB	1200	1200	1350	1350	1350	1500	1500
Weight	14.1	14.5	14.9	15.3	15.8	16.1	16.9

08S050																			
Specification / Effective Stroke	100	150	200	250	300	350	400	450	500	550	600	650	700	750	800	850	900	950	1000
LT	550	600	650	700	750	800	850	900	950	1000	1050	1100	1150	1200	1250	1300	1350	1400	1450
N	3	3	4	4	4	5	5	5	6	6	6	7	7	7	8	8	8	9	9
LA	50	75	25	50	75	25	50	75	25	50	75	25	50	75	25	50	75	25	50
LB	450	450	600	600	600	750	750	750	900	900	900	1050	1050	1050	1200	1200	1200	1350	1350
Weight	9.2	9.6	10.0	10.5	10.9	11.3	11.6	12.1	12.5	12.9	13.3	13.8	14.1	14.5	14.9	15.3	15.8	16.2	16.5

08S050				
Specification / Effective Stroke	1050	1100	1150	1200
LT	1500	1550	1600	1650
N	9	10	10	10
LA	75	25	50	75
LB	1350	1500	1500	1500
Weight	16.9	17.4	17.8	18.2

Acceleration-Payload Curve

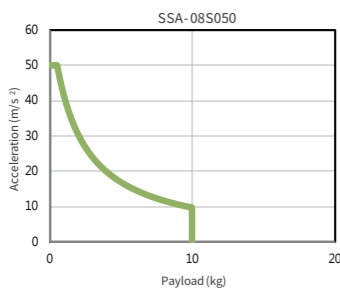

Velocity-Stroke Curve

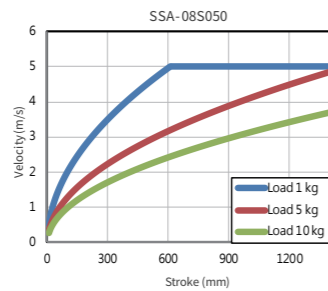

Offset Load Capacity Curve

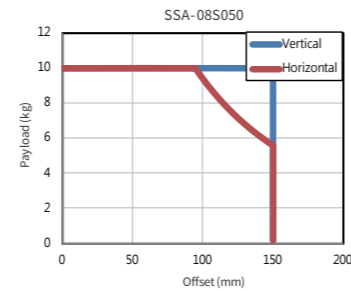

Model Description

LMSSA-08S050-□-□□□□-□□.□□-S-B-A000

Cables
Please refer to page 5, 9, 11

Number of forcers
1 : Single forcer
2 : Dual forcers

Stroke(mm)
100~1400 : Single forcer
100~1200 : Dual forcers

SSA-08 Series Single Forcer

SSA-08S050
M cover
Stroke
100~1400

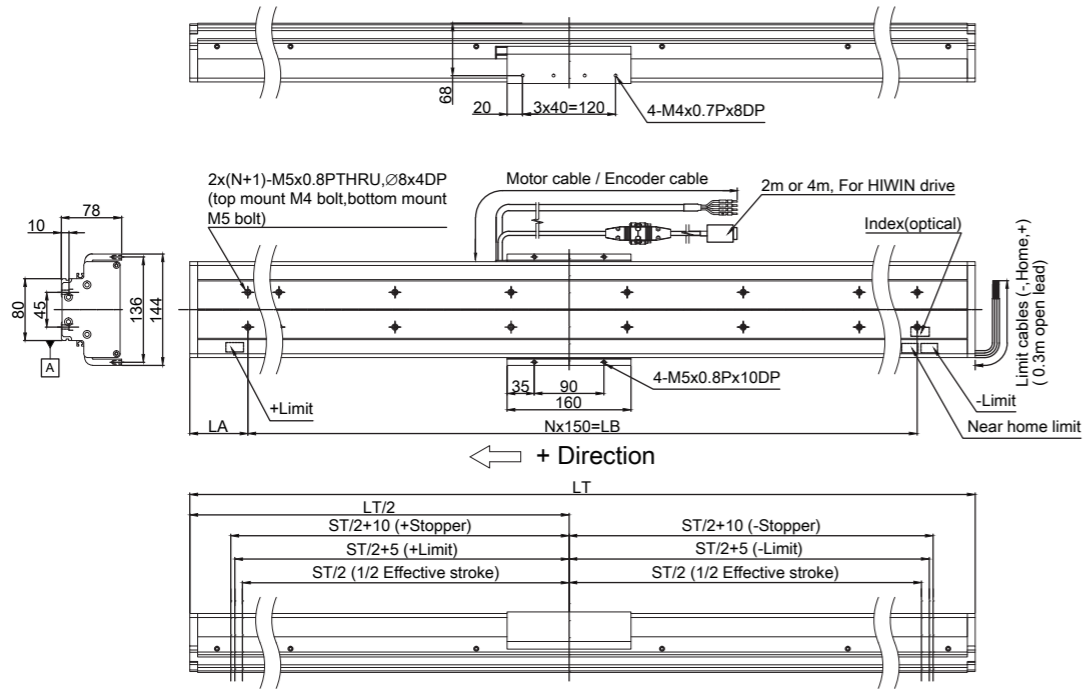

SSA-08 Series Dual Forcers

SSA-08S050
M cover
Stroke
100~1200

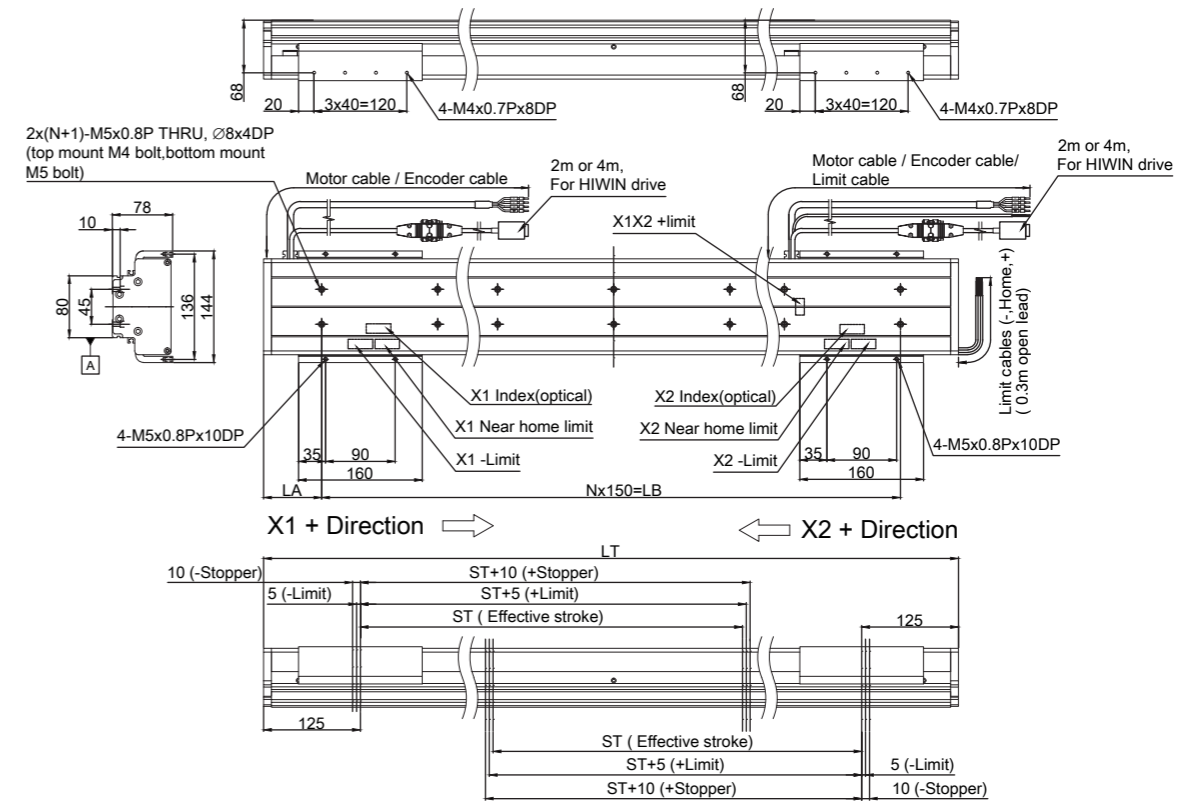

08S050																			
Specification / Effective Stroke	100	150	200	250	300	350	400	450	500	550	600	650	700	750	800	850	900	950	1000
LT	350	400	450	500	550	600	650	700	750	800	850	900	950	1000	1050	1100	1150	1200	1250
N	2	2	2	3	3	3	4	4	4	5	5	5	6	6	6	7	7	7	8
LA	25	50	75	25	50	75	25	50	75	25	50	75	25	50	75	25	50	75	25
LB	300	300	300	450	450	450	600	600	600	750	750	750	900	900	900	1050	1050	1050	1200
Weight	6.8	7.3	7.8	8.2	8.7	9.1	9.5	9.9	10.4	10.9	11.3	11.8	12.1	12.6	13.1	13.5	14.0	14.4	14.8

08S050							
Specification / Effective Stroke	1050	1100	1150	1200	1250	1300	1400
LT	1300	1350	1400	1450	1500	1550	1650
N	8	8	9	9	9	10	10
LA	50	75	25	50	75	25	75
LB	1200	1200	1350	1350	1350	1500	1500
Weight	15.2	15.7	16.2	16.6	17.1	17.4	18.3

08S050																			
Specification / Effective Stroke	100	150	200	250	300	350	400	450	500	550	600	650	700	750	800	850	900	950	1000
LT	550	600	650	700	750	800	850	900	950	1000	1050	1100	1150	1200	1250	1300	1350	1400	1450
N	3	3	4	4	4	5	5	5	6	6	6	7	7	7	8	8	8	9	9
LA	50	75	25	50	75	25	50	75	25	50	75	25	50	75	25	50	75	25	50
LB	450	450	600	600	600	750	750	750	900	900	900	1050	1050	1050	1200	1200	1200	1350	1350
Weight	10.0	10.5	10.9	11.4	11.9	12.3	12.7	13.1	13.6	14.0	14.5	15.0	15.3	15.8	16.2	16.7	17.2	17.6	18.0

08S050				
Specification / Effective Stroke	1050	1100	1150	1200
LT	1500	1550	1600	1650
N	9	10	10	10
LA	75	25	50	75
LB	1350	1500	1500	1500
Weight	18.4	18.9	19.3	19.8

Acceleration-Payload Curve

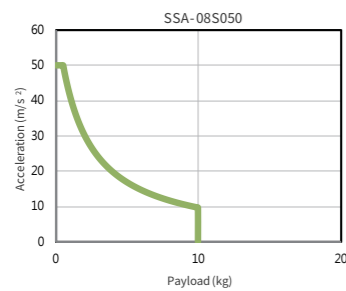

Velocity-Stroke Curve

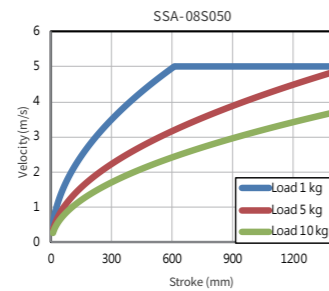

Offset Load Capacity Curve

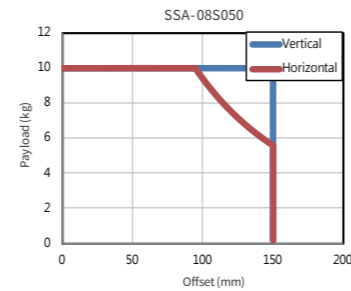

Model Description

LMSSA-08S050-□-□□□□-□□.□□-M-B-A000

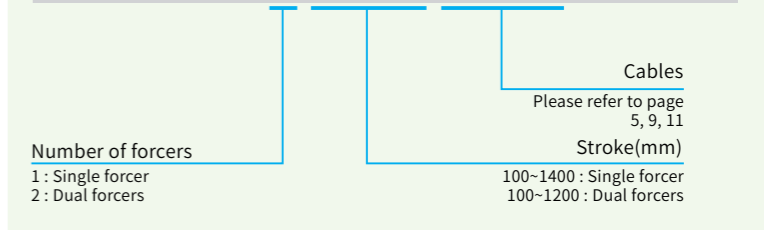

SSA-08 Series Single Forcer

SSA-08S100
S cover Stroke 100~1300

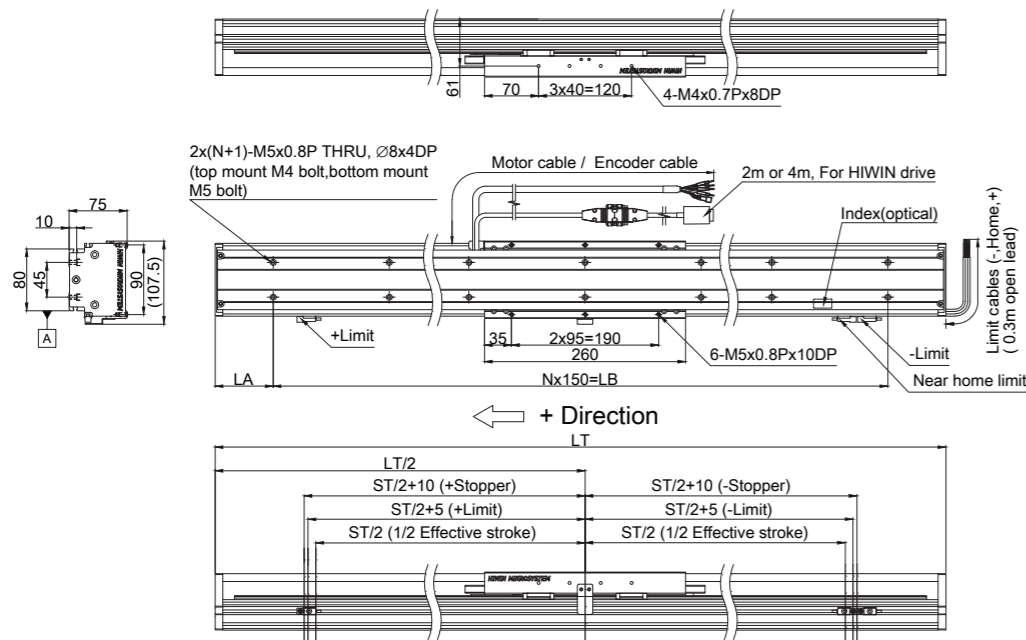

SSA-08 Series Dual Forcers

SSA-08S100
S cover Stroke 100~1000

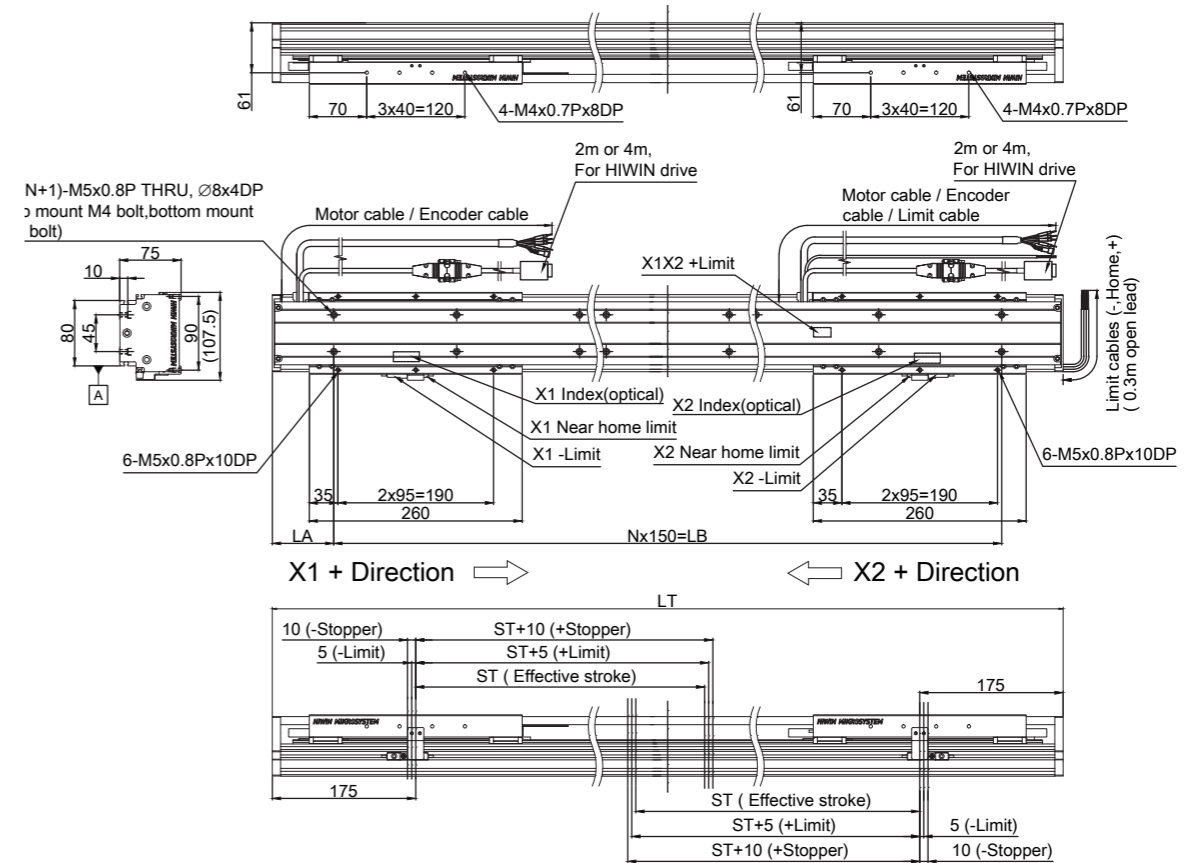

08S100																			
Specification / Effective Stroke	100	150	200	250	300	350	400	450	500	550	600	650	700	750	800	850	900	950	1000
LT	450	500	550	600	650	700	750	800	850	900	950	1000	1050	1100	1150	1200	1250	1300	1350
N	2	3	3	3	4	4	4	5	5	5	6	6	6	7	7	7	8	8	8
LA	75	25	50	75	25	50	75	25	50	75	25	50	75	25	50	75	25	50	75
LB	300	450	450	450	600	600	600	750	750	750	900	900	900	1050	1050	1050	1200	1200	1200
Weight	8.1	8.5	8.9	9.4	9.8	10.1	10.5	10.9	11.4	11.8	12.2	12.5	13.0	13.4	13.8	14.2	14.7	15.0	15.4

08S100																			
Specification / Effective Stroke	100	150	200	250	300	350	400	450	500	550	600	650	700	750	800	850	900	950	1000
LT	750	800	850	900	950	1000	1050	1100	1150	1200	1250	1300	1350	1400	1450	1500	1550	1600	1650
N	4	5	5	5	6	6	6	7	7	7	8	8	8	9	9	9	10	10	10
LA	75	25	50	75	25	50	75	25	50	75	25	50	75	25	50	75	25	50	75
LB	600	750	750	750	900	900	900	1050	1050	1050	1200	1200	1200	1350	1350	1350	1500	1500	1500
Weight	12.5	12.9	13.3	13.7	14.0	14.5	14.9	15.3	15.8	16.2	16.5	16.9	17.3	17.8	18.2	18.6	18.9	19.3	19.8

08S100						
Specification / Effective Stroke	1050	1100	1150	1200	1250	1300
LT	1400	1450	1500	1550	1600	1650
N	9	9	9	10	10	10
LA	25	50	75	25	50	75
LB	1350	1350	1350	1500	1500	1500
Weight	15.8	16.2	16.7	17.1	17.4	17.8

Acceleration-Payload Curve

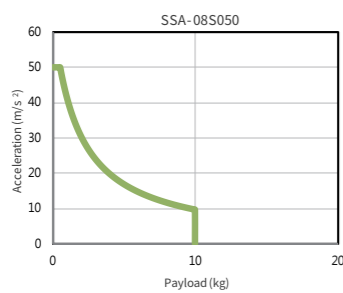

Velocity-Stroke Curve

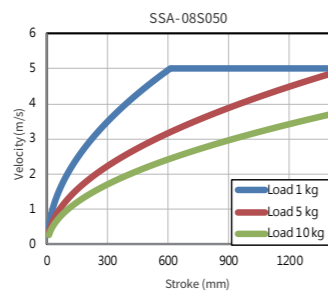

Offset Load Capacity Curve

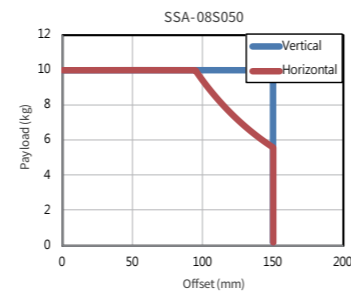

Model Description

LMSSA-08S100-□-□□□□-□□.□□-S-B-A000

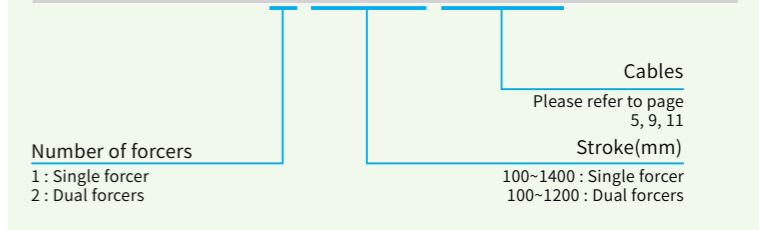

SSA-08 Series Single Forcer

SSA-08S100 M cover Stroke 100~1300

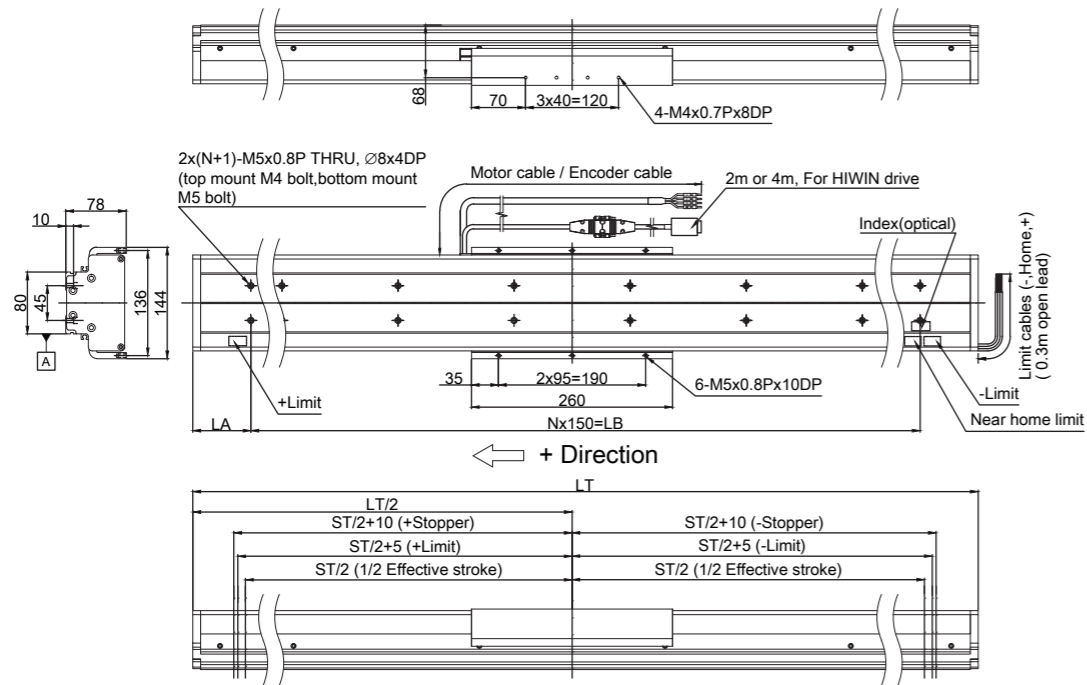

SSA-08 Series Dual Forcers

SSA-08S100 M cover Stroke 100~1000

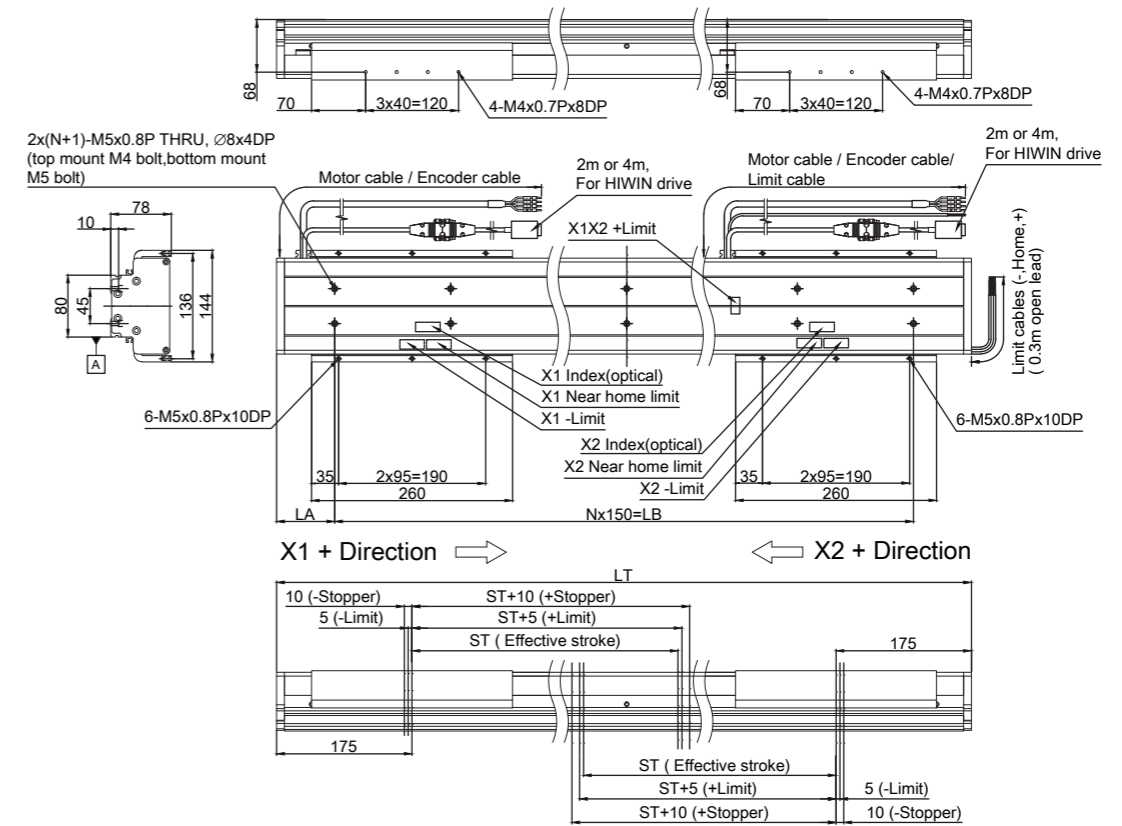

08S100																			
Specification / Effective Stroke	100	150	200	250	300	350	400	450	500	550	600	650	700	750	800	850	900	950	1000
LT	450	500	550	600	650	700	750	800	850	900	950	1000	1050	1100	1150	1200	1250	1300	1350
N	2	3	3	3	4	4	4	5	5	5	6	6	6	7	7	7	8	8	8
LA	75	25	50	75	25	50	75	25	50	75	25	50	75	25	50	75	25	50	75
LB	300	450	450	450	600	600	600	750	750	750	900	900	900	1050	1050	1050	1200	1200	1200
Weight	9.0	9.4	9.9	10.3	10.8	11.1	11.6	12.1	12.5	13.0	13.4	13.8	14.3	14.7	15.2	15.6	16.1	16.4	16.9

08S100																			
Specification / Effective Stroke	100	150	200	250	300	350	400	450	500	550	600	650	700	750	800	850	900	950	1000
LT	750	800	850	900	950	1000	1050	1100	1150	1200	1250	1300	1350	1400	1450	1500	1550	1600	1650
N	4	5	5	5	6	6	6	7	7	7	8	8	8	9	9	9	10	10	10
LA	75	25	50	75	25	50	75	25	50	75	25	50	75	25	50	75	25	50	75
LB	600	750	750	750	900	900	900	1050	1050	1050	1200	1200	1200	1350	1350	1350	1500	1500	1500
Weight	14.0	14.5	15.0	15.4	15.8	16.2	16.7	17.1	17.6	18.1	18.4	18.9	19.3	19.8	20.2	20.7	21.1	21.5	22.0

08S100						
Specification / Effective Stroke	1050	1100	1150	1200	1250	1300
LT	1400	1450	1500	1550	1600	1650
N	9	9	9	10	10	10
LA	25	50	75	25	50	75
LB	1350	1350	1350	1500	1500	1500
Weight	17.4	17.8	18.3	18.7	19.1	19.5

Acceleration-Payload Curve

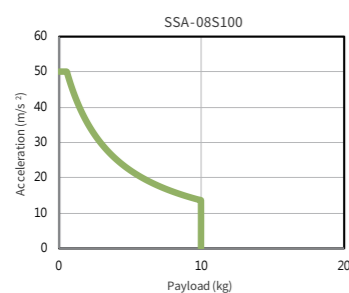

Velocity-Stroke Curve

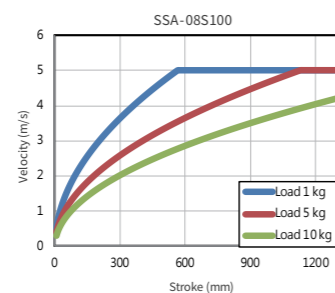

Offset Load Capacity Curve

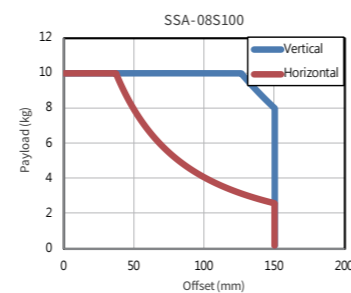

Model Description

LMSSA-08S100-□-□□□□-□□.□□-M-B-A0000

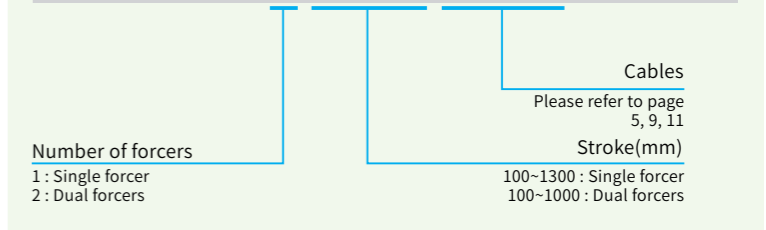

SSA-10 Series Single Forcer

SSA-10S100 Stroke 100~1400 S cover

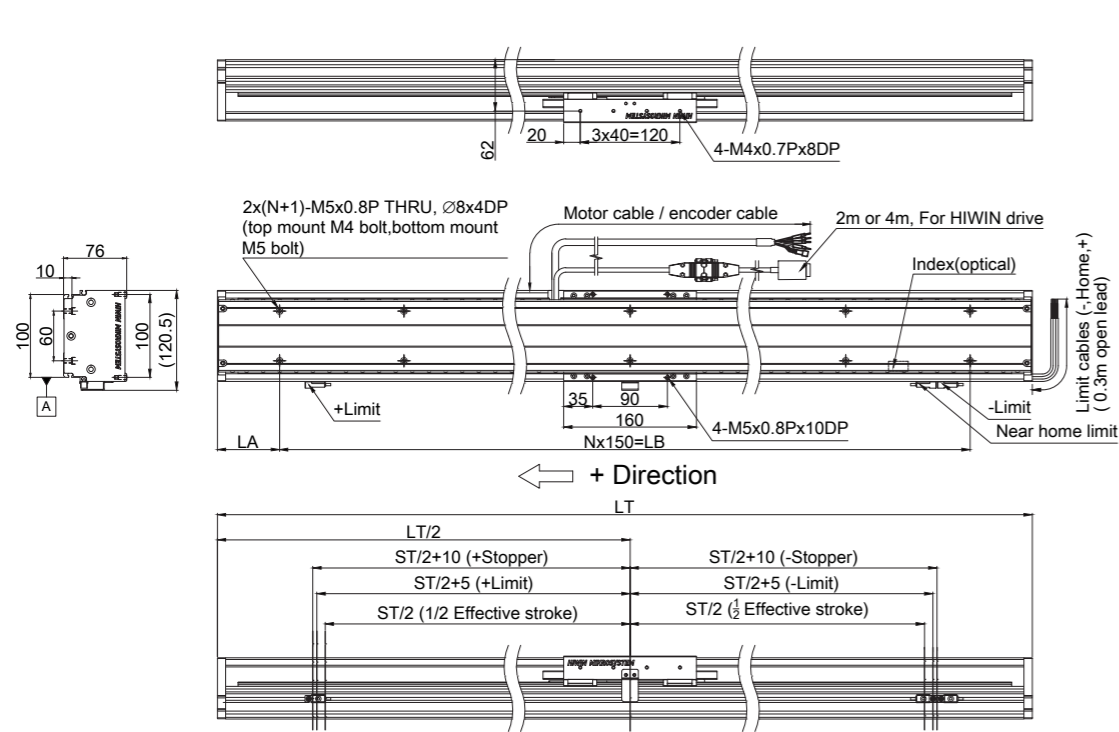

SSA-10 Series Dual Forcers

SSA-10S100 Stroke 100~1200 S cover

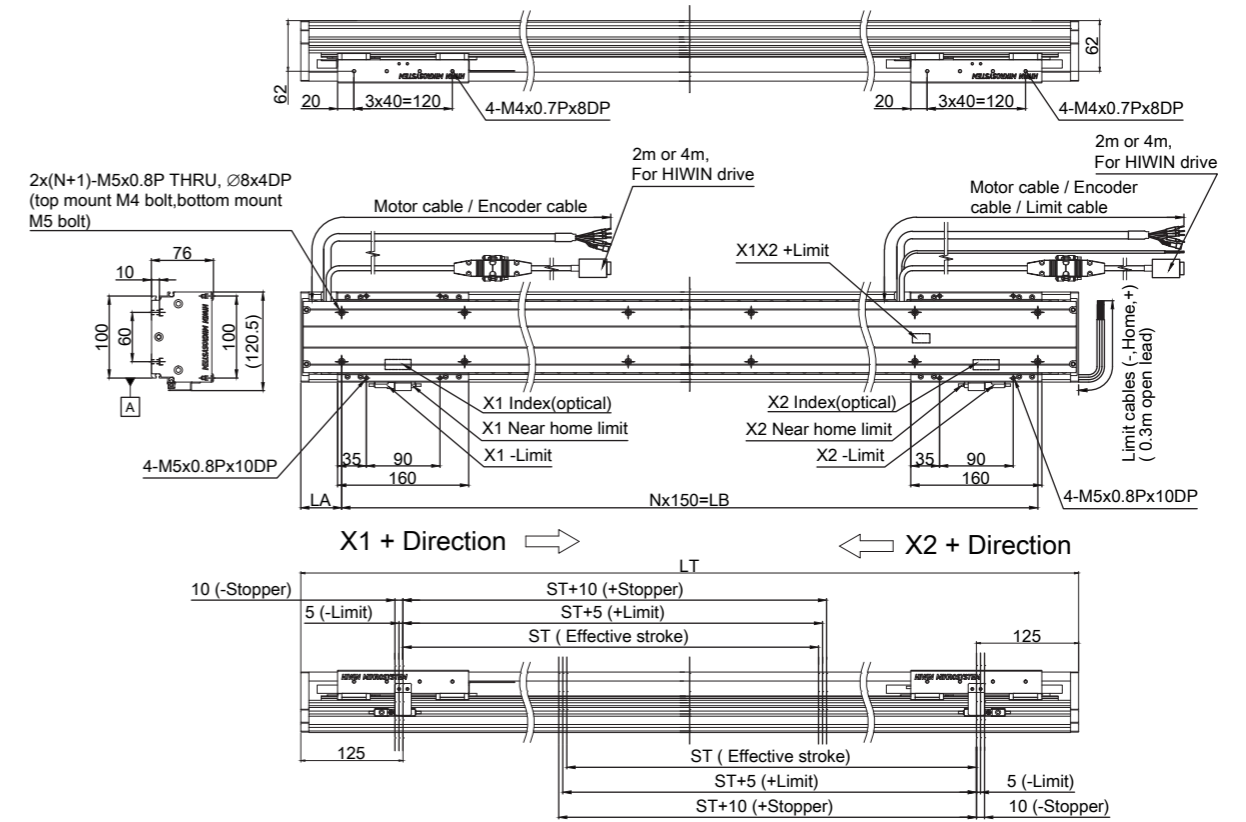

10S100																			
Specification / Effective Stroke	100	150	200	250	300	350	400	450	500	550	600	650	700	750	800	850	900	950	1000
LT	350	400	450	500	550	600	650	700	750	800	850	900	950	1000	1050	1100	1150	1200	1250
N	2	2	2	3	3	3	4	4	4	5	5	5	6	6	6	7	7	7	8
LA	25	50	75	25	50	75	25	50	75	25	50	75	25	50	75	25	50	75	25
LB	300	300	300	450	450	450	600	600	600	750	750	750	900	900	900	1050	1050	1050	1200
Weight	7.4	7.9	8.5	8.8	9.3	9.9	10.4	10.9	11.5	11.8	12.3	12.9	13.4	13.9	14.5	14.8	15.3	15.9	16.4

10S100																			
Specification / Effective Stroke	100	150	200	250	300	350	400	450	500	550	600	650	700	750	800	850	900	950	1000
LT	350	400	450	500	550	600	650	700	750	800	850	900	950	1000	1050	1100	1150	1200	1250
N	2	2	2	3	3	3	4	4	4	5	5	5	6	6	6	7	7	7	8
LA	25	50	75	25	50	75	25	50	75	25	50	75	25	50	75	25	50	75	25
LB	300	300	300	450	450	450	600	600	600	750	750	750	900	900	900	1050	1050	1050	1200
Weight	7.4	7.9	8.5	8.8	9.3	9.9	10.4	10.9	11.5	11.8	12.3	12.9	13.4	13.9	14.5	14.8	15.3	15.9	16.4

10S100							
Specification / Effective Stroke	1050	1100	1150	1200	1250	1300	1400
LT	1300	1350	1400	1450	1500	1550	1650
N	8	8	9	9	9	10	10
LA	50	75	25	50	75	25	75
LB	1200	1200	1350	1350	1350	1500	1500
Weight	16.9	17.5	17.8	18.3	18.9	19.4	20.5

10S050							
Specification / Effective Stroke	1050	1100	1150	1200	1250	1300	1400
LT	1300	1350	1400	1450	1500	1550	1650
N	8	8	9	9	9	10	10
LA	50	75	25	50	75	25	75
LB	1200	1200	1350	1350	1350	1500	1500
Weight	16.9	17.5	17.8	18.3	18.9	19.4	20.5

Acceleration-Payload Curve

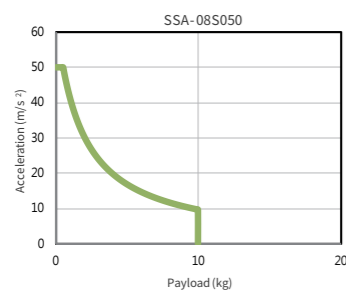

Velocity-Stroke Curve

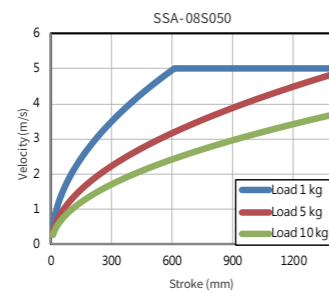

Offset Load Capacity Curve

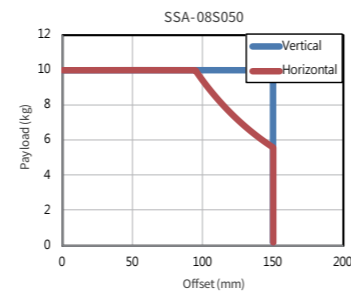

Model Description

LMSSA-08S100-□-□□□□-□□.□□-S-B-A000

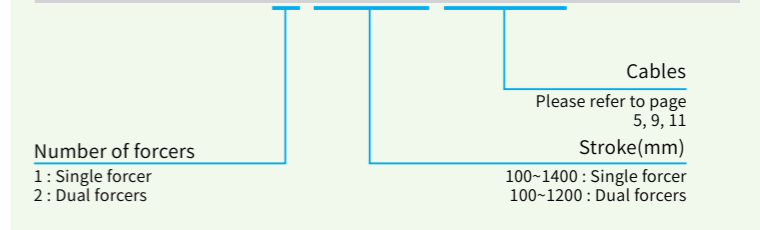

SSA-10 Series Single Forcer

SSA-10S100
M cover Stroke 100~1400

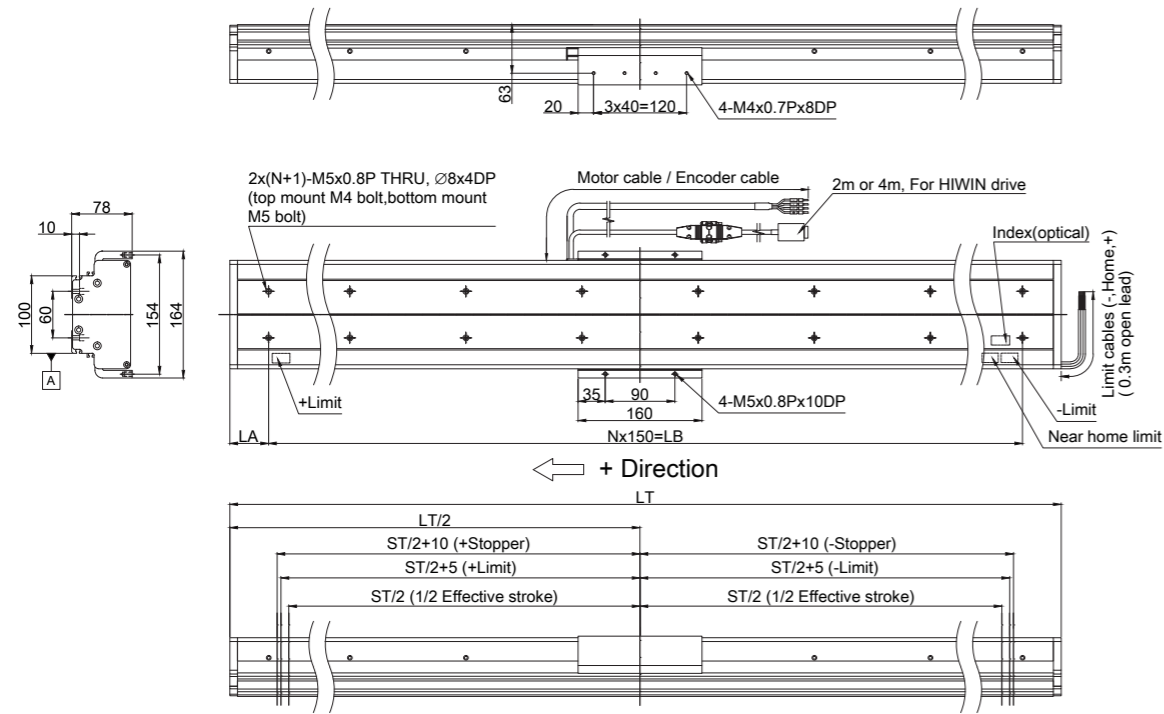

SSA-10 Series Dual Forcers

SSA-10S100
M cover Stroke 100~1200

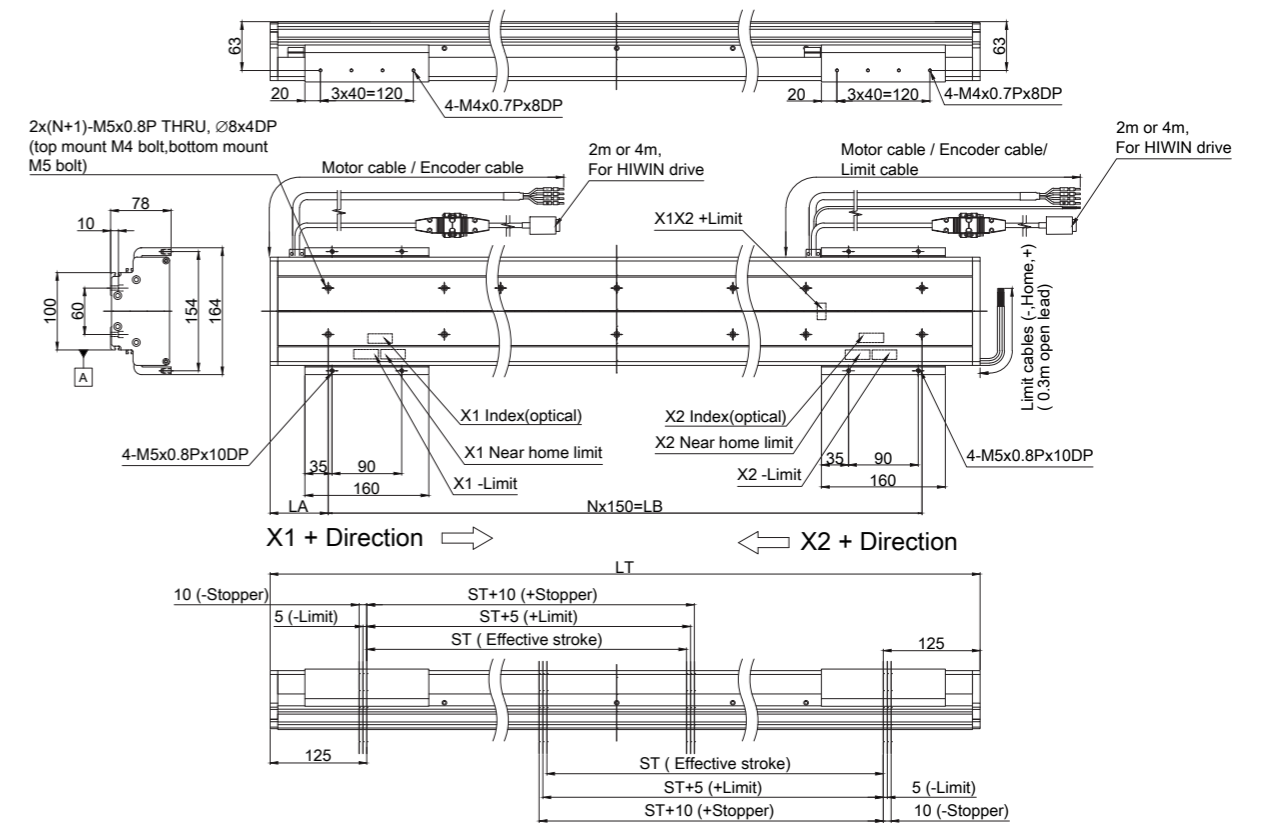

10S100																			
Specification / Effective Stroke	100	150	200	250	300	350	400	450	500	550	600	650	700	750	800	850	900	950	1000
LT	350	400	450	500	550	600	650	700	750	800	850	900	950	1000	1050	1100	1150	1200	1250
N	2	2	2	3	3	3	4	4	4	5	5	5	6	6	6	7	7	7	8
LA	25	50	75	25	50	75	25	50	75	25	50	75	25	50	75	25	50	75	25
LB	300	300	300	450	450	450	600	600	600	750	750	750	900	900	900	1050	1050	1050	1200
Weight	7.5	8.0	8.5	8.9	9.4	9.9	10.4	10.9	11.4	11.7	12.2	12.7	13.2	13.7	14.2	14.5	15.0	15.5	16.1

10S100							
Specification / Effective Stroke	1050	1100	1150	1200	1250	1300	1400
LT	1300	1350	1400	1450	1500	1550	1650
N	8	8	9	9	9	10	10
LA	50	75	25	50	75	25	75
LB	1200	1200	1350	1350	1350	1500	1500
Weight	16.6	17.1	17.4	17.9	18.4	18.9	19.9

10S100																			
Specification / Effective Stroke	100	150	200	250	300	350	400	450	500	550	600	650	700	750	800	850	900	950	1000
LT	550	600	650	700	750	800	850	900	950	1000	1050	1100	1150	1200	1250	1300	1350	1400	1450
N	3	3	4	4	4	5	5	5	6	6	6	7	7	7	8	8	8	9	9
LA	50	75	25	50	75	25	50	75	25	50	75	25	50	75	25	50	75	25	50
LB	450	450	600	600	600	750	750	750	900	900	900	1050	1050	1050	1200	1200	1200	1350	1350
Weight	11.0	11.5	12.0	12.3	12.8	13.3	13.8	14.3	14.8	15.2	15.7	16.2	16.7	17.2	17.7	18.0	18.5	19.0	19.5

10S100				
Specification / Effective Stroke	1050	1100	1150	1200
LT	1500	1550	1600	1650
N	9	10	10	10
LA	75	25	50	75
LB	1350	1500	1500	1500
Weight	20.0	20.5	20.9	21.4

Acceleration-Payload Curve

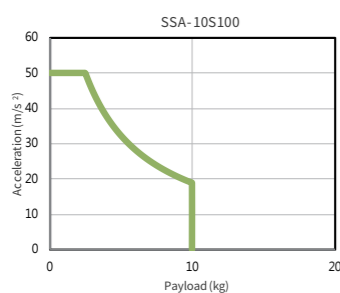

Velocity-Stroke Curve

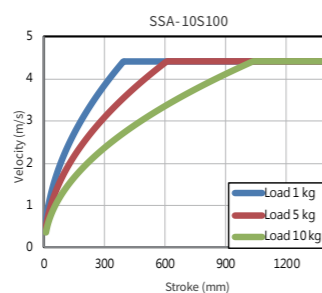

Offset Load Capacity Curve

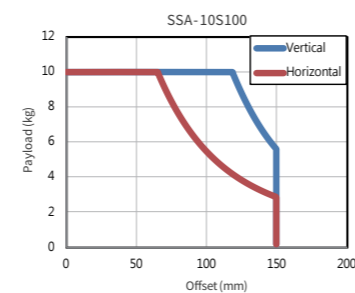

Model Description

LMSSA-10S100-□-□□□□-□□.□□-M-B-A000

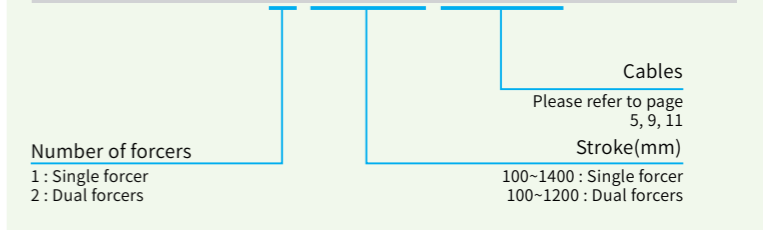

SSA-10 Series Single Forcer

SSA-10S200
S cover
Stroke
100~1300

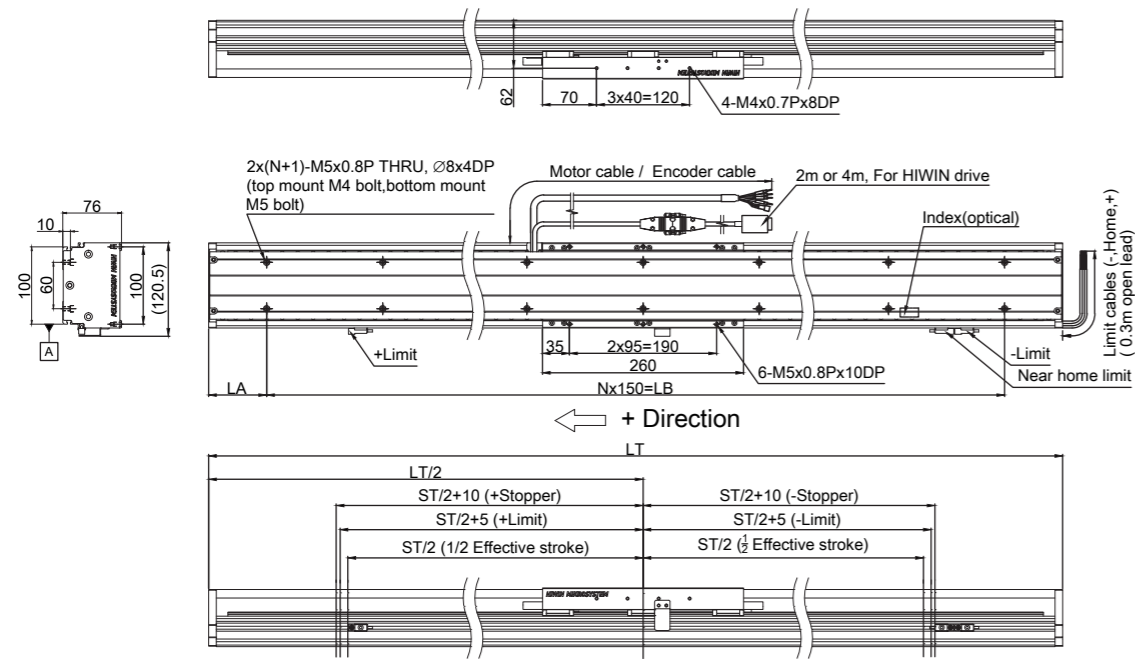

SSA-10 Series Dual Forcers

SSA-10S200
S cover
Stroke
100~1000

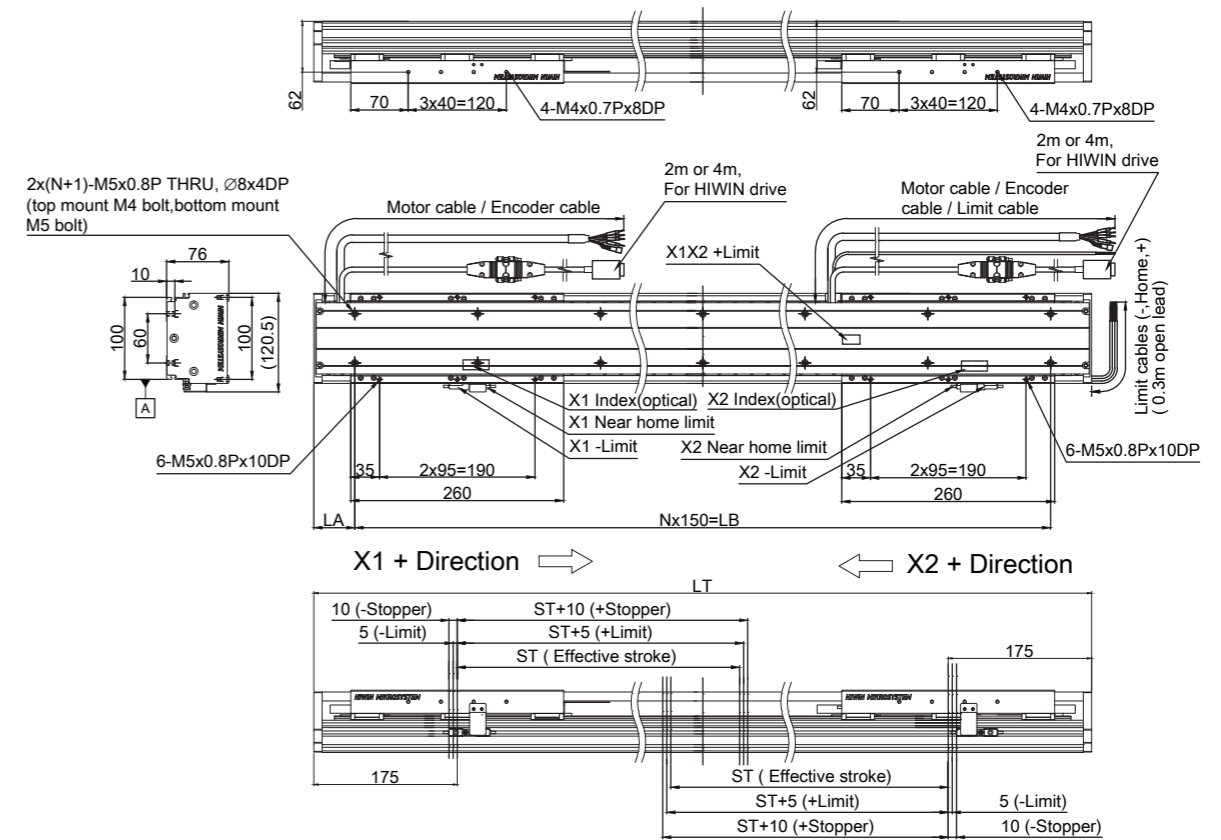

10S200																			
Specification / Effective Stroke	100	150	200	250	300	350	400	450	500	550	600	650	700	750	800	850	900	950	1000
LT	450	500	550	600	650	700	750	800	850	900	950	1000	1050	1100	1150	1200	1250	1300	1350
N	2	3	3	3	4	4	4	5	5	5	6	6	6	7	7	7	8	8	8
LA	75	25	50	75	25	50	75	25	50	75	25	50	75	25	50	75	25	50	75
LB	300	450	450	450	600	600	600	750	750	750	900	900	900	1050	1050	1050	1200	1200	1200
Weight	9.6	10.1	10.5	11.0	11.5	12.0	12.6	13.1	13.4	14.0	14.5	15.0	15.6	16.1	16.4	17.0	17.5	18.0	18.6

10S200																			
Specification / Effective Stroke	100	150	200	250	300	350	400	450	500	550	600	650	700	750	800	850	900	950	1000
LT	750	800	850	900	950	1000	1050	1100	1150	1200	1250	1300	1350	1400	1450	1500	1550	1600	1650
N	4	5	5	5	6	6	6	7	7	7	8	8	8	9	9	9	10	10	10
LA	75	25	50	75	25	50	75	25	50	75	25	50	75	25	50	75	25	50	75
LB	600	750	750	750	900	900	900	1050	1050	1050	1200	1200	1200	1350	1350	1350	1500	1500	1500
Weight	14.9	15.5	16.0	16.5	17.0	17.4	17.9	18.5	19.0	19.5	20.0	20.4	20.9	21.5	22.0	22.5	23.0	23.4	23.9

10S200						
Specification / Effective Stroke	1050	1100	1150	1200	1250	1300
LT	1400	1450	1500	1550	1600	1650
N	9	9	9	10	10	10
LA	25	50	75	25	50	75
LB	1350	1350	1350	1500	1500	1500
Weight	19.1	19.4	20.0	20.5	21.0	21.6

Acceleration-Payload Curve

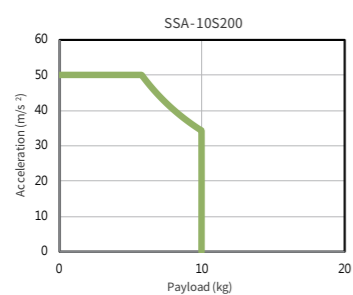

Velocity-Stroke Curve

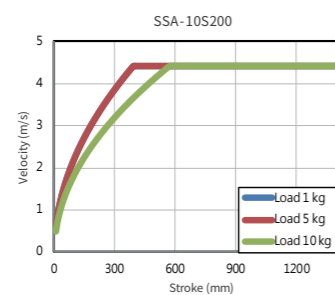

Offset Load Capacity Curve

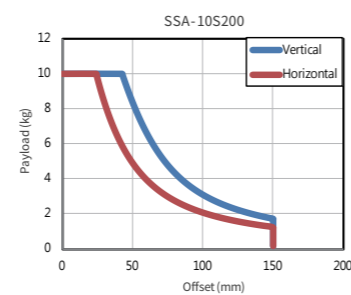

Model Description

LMSSA-08S200-□-□□□□-□□.□□-S-B-A0000

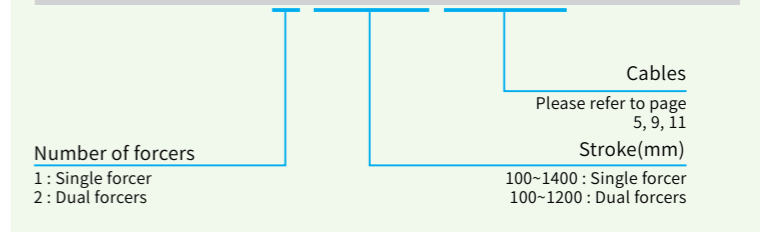

SSA-10 Series Single Forcer

SSA-10S200
M cover
Stroke
100~1300

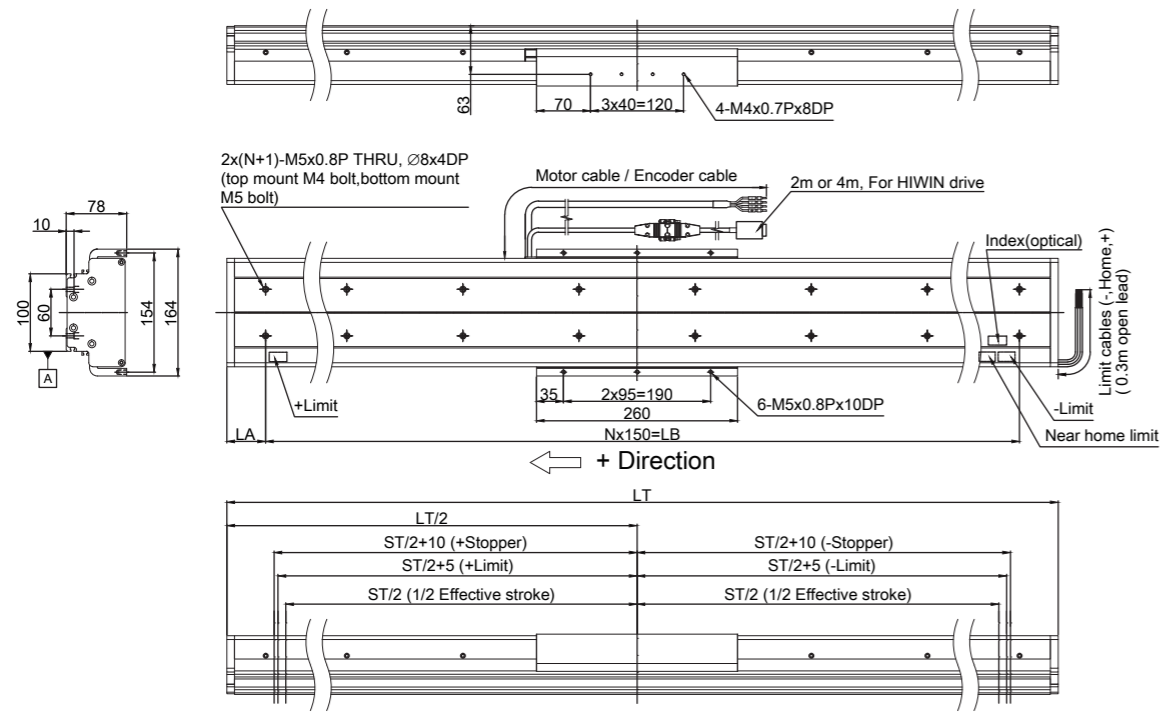

SSA-10 Series Dual Forcers

SSA-10S200
M cover
Stroke
100~1000

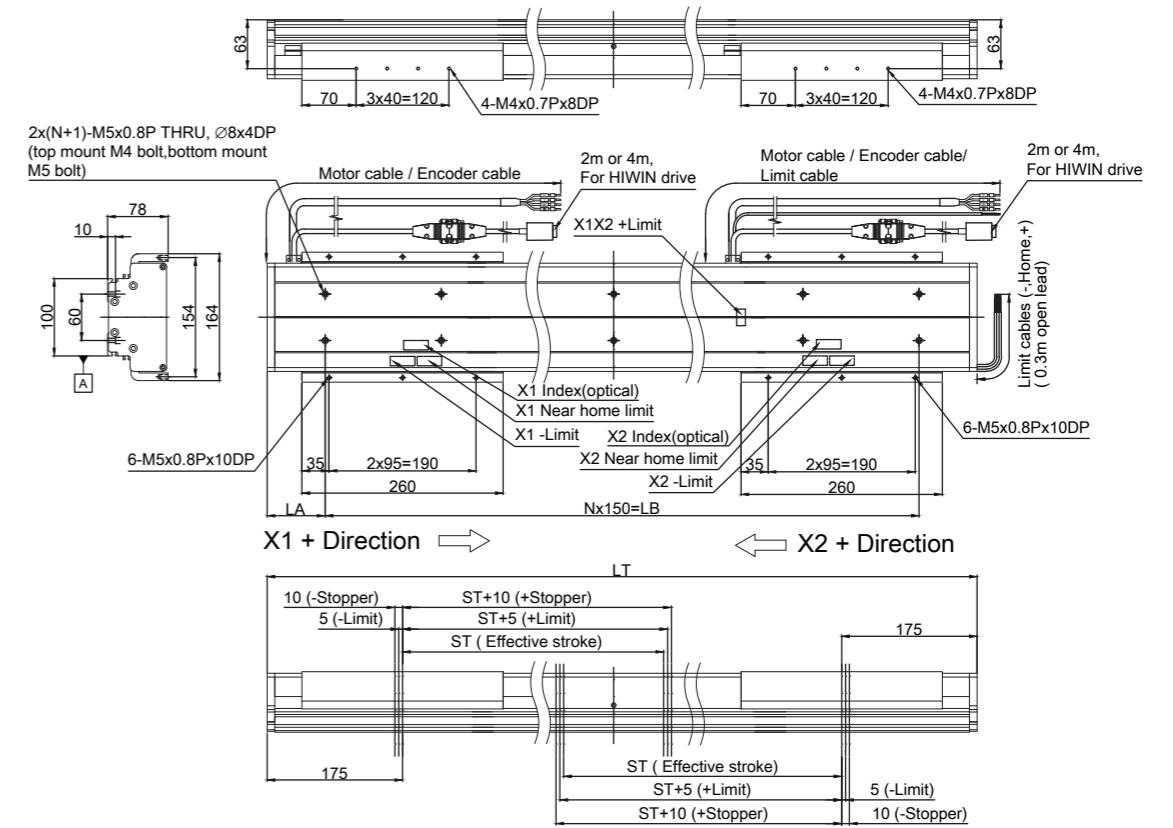

10S200																			
Specification / Effective Stroke	100	150	200	250	300	350	400	450	500	550	600	650	700	750	800	850	900	950	1000
LT	450	500	550	600	650	700	750	800	850	900	950	1000	1050	1100	1150	1200	1250	1300	1350
N	2	3	3	3	4	4	4	5	5	5	6	6	6	7	7	7	8	8	8
LA	75	25	50	75	25	50	75	25	50	75	25	50	75	25	50	75	25	50	75
LB	300	450	450	450	600	600	600	750	750	750	900	900	900	1050	1050	1050	1200	1200	1200
Weight	9.8	10.3	10.7	11.2	11.7	12.2	12.7	13.2	13.5	14.0	14.5	15.0	15.5	16.0	16.3	16.8	17.4	17.9	18.4

10S200						
Specification / Effective Stroke	1050	1100	1150	1200	1250	1300
LT	1400	1450	1500	1550	1600	1650
N	9	9	9	10	10	10
LA	25	50	75	25	50	75
LB	1350	1350	1350	1500	1500	1500
Weight	18.9	19.2	19.7	20.2	20.7	21.2

10S200																			
Specification / Effective Stroke	100	150	200	250	300	350	400	450	500	550	600	650	700	750	800	850	900	950	1000
LT	750	800	850	900	950	1000	1050	1100	1150	1200	1250	1300	1350	1400	1450	1500	1550	1600	1650
N	4	5	5	5	6	6	6	7	7	7	8	8	8	9	9	9	10	10	10
LA	75	25	50	75	25	50	75	25	50	75	25	50	75	25	50	75	25	50	75
LB	600	750	750	750	900	900	900	1050	1050	1050	1200	1200	1200	1350	1350	1350	1500	1500	1500
Weight	15.4	15.9	16.4	16.9	17.4	17.8	18.3	18.8	19.3	19.8	20.3	20.6	21.1	21.6	22.1	22.6	23.1	23.5	24.0

Acceleration-Payload Curve

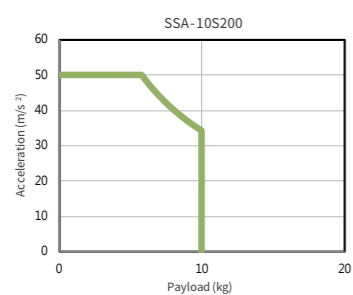

Velocity-Stroke Curve

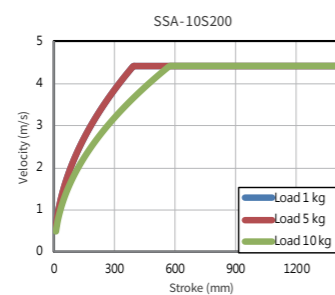

Offset Load Capacity Curve

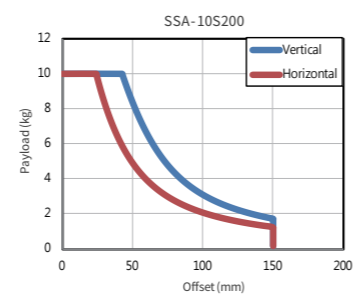

Model Description

LMSSA-10S200-□-□□□□-□□.□□-M-B-A0000

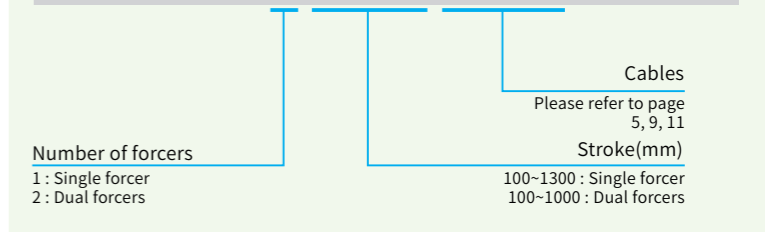

SSA-13 Series Single Forcer

SSA-13S100
S cover
Stroke
100~2700

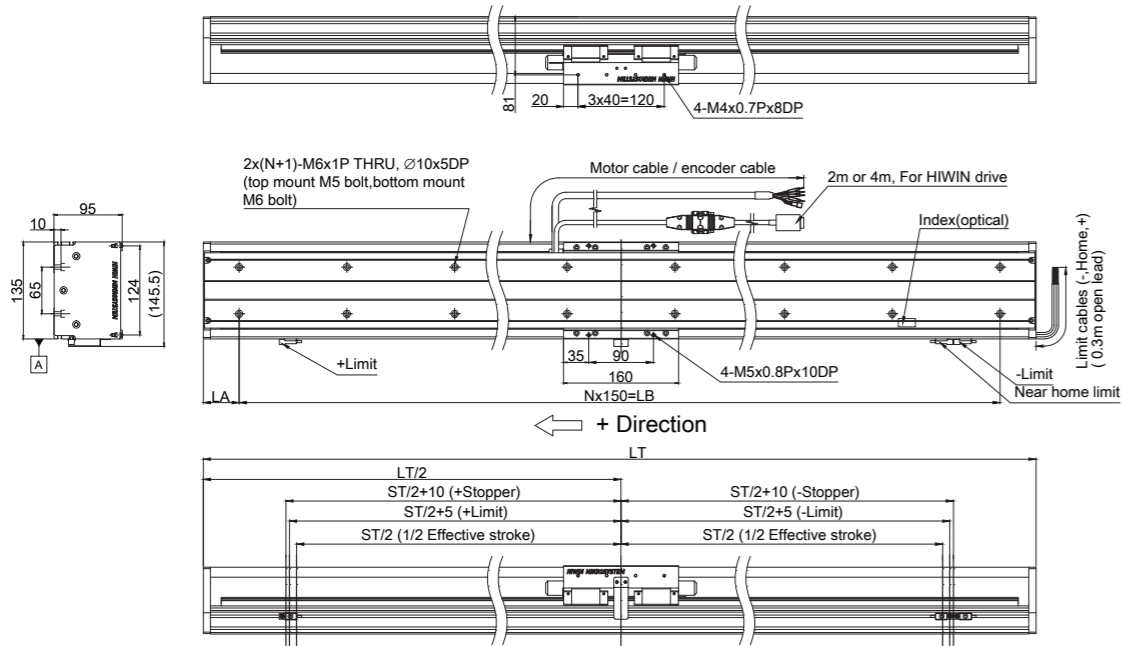

13S100																				
Specification / Effective Stroke	100	150	200	250	300	350	400	450	500	550	600	650	700	750	800	850	900	950	1000	1050
LT	350	400	450	500	550	600	650	700	750	800	850	900	950	1000	1050	1100	1150	1200	1250	1300
N	2	2	2	3	3	3	4	4	4	5	5	5	6	6	6	7	7	7	8	8
LA	25	50	75	25	50	75	25	50	75	25	50	75	25	50	75	25	50	75	25	50
LB	300	300	300	450	450	450	600	600	600	750	750	750	900	900	900	1050	1050	1050	1200	1200
Weight	10.6	11.4	12.2	12.9	13.7	14.5	15.3	16.1	16.9	17.6	18.4	19.2	20.0	20.9	21.7	22.3	23.1	24.0	24.8	25.6

13S100																			
Specification / Effective Stroke	1100	1150	1200	1250	1300	1400	1500	1600	1700	1800	1900	2000	2100	2200	2300	2400	2500	2600	2700
LT	1350	1400	1450	1500	1550	1650	1750	1850	1950	2050	2150	2250	2350	2450	2550	2650	2750	2850	2950
N	8	9	9	9	10	10	11	12	12	13	14	14	15	16	16	17	18	18	19
LA	75	25	50	75	25	75	50	25	75	50	25	75	50	25	75	50	25	75	50
LB	1200	1350	1350	1350	1500	1500	1650	1800	1800	1950	2100	35.2	2250	2400	2400	2550	2700	2700	2850
Weight	26.4	27.1	27.9	28.7	29.5	31.1	32.6	34.2	35.9	37.3	39	40.6	42.1	43.7	45.3	46.8	48.4	50.1	51.5

Acceleration-Payload Curve

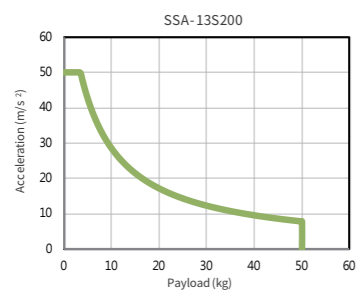

Velocity-Stroke Curve

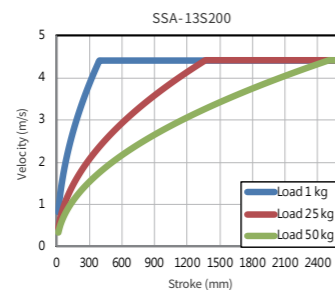

Offset Load Capacity Curve

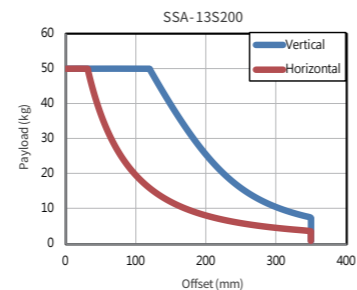

SSA-13 Series Dual Forcers

SSA-13S100
S cover
Stroke
100~2500

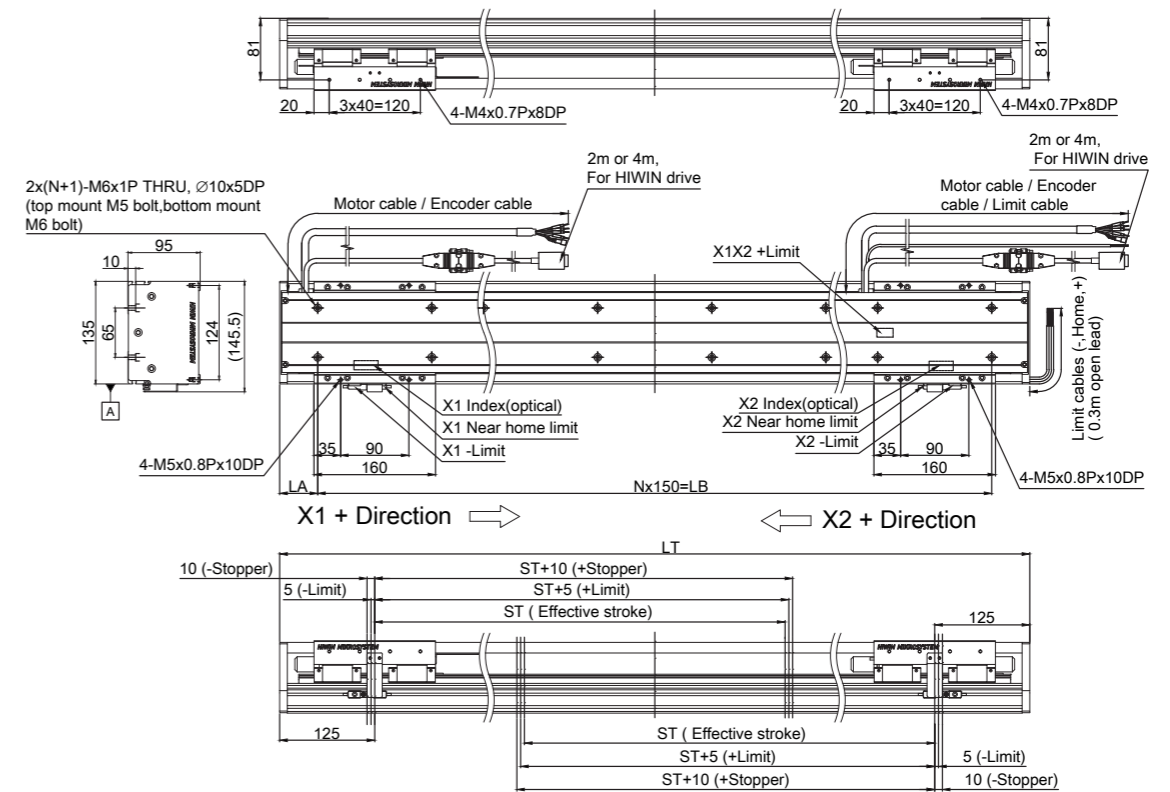

13S200																				
Specification / Effective Stroke	100	150	200	250	300	350	400	450	500	550	600	650	700	750	800	850	900	950	1000	1050
LT	550	600	650	700	750	800	850	900	950	1000	1050	1100	1150	1200	1250	1300	1350	1400	1450	1500
N	3	3	4	4	4	5	5	5	6	6	6	7	7	7	8	8	8	9	9	9
LA	50	75	25	50	75	25	50	75	25	50	75	25	50	75	25	50	75	25	50	75
LB	450	450	600	600	600	750	750	750	900	900	900	1050	1050	1050	1200	1200	1200	1350	1350	1350
Weight	16.1	16.9	17.8	18.4	19.2	20.0	20.9	21.7	22.5	23.1	24.0	24.8	25.6	26.4	27.2	27.9	28.7	29.5	30.3	31.1

13S200																	
Specification / Effective Stroke	1100	1150	1200	1250	1300	1400	1500	1600	1700	1800	1900	2000	2100	2200	2300	2400	2500
LT	1550	1600	1650	1700	1750	1850	1950	2050	2150	2250	2350	2450	2550	2650	2750	2850	2950
N	10	10	10	11	11	12	12	13	14	14	15	16	16	17	18	18	19
LA	25	50	75	25	50	25	75	50	25	75	50	25	75	50	25	75	50
LB	1500	1500	1500	1650	1650	1800	1800	1950	2100	2100	2250	2400	2400	2550	2700	2700	2850
Weight	32.0	32.6	33.4	34.2	35.1	36.7	38.2	39.8	41.4	42.9	44.5	46.2	47.6	49.3	50.9	52.4	54

Model Description

LMSSA-13S200-□-□□□□-□□.□□-S-B-A000

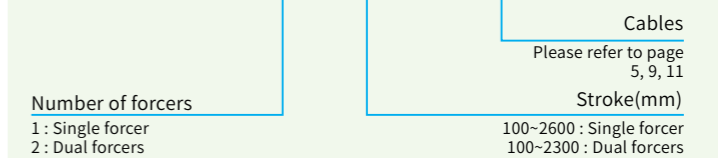

SSA-13 Series Single Forcer

SSA-13S100
M cover **Stroke**
100~2700

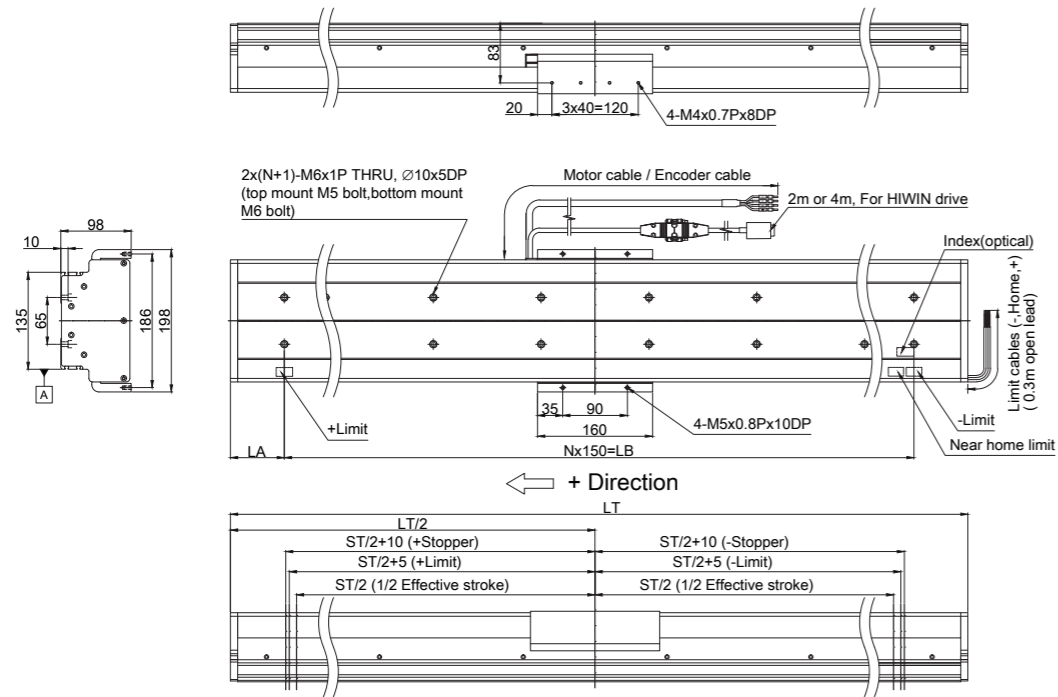

SSA-13 Series Dual Forcers

SSA-13S100
M cover **Stroke**
100~2500

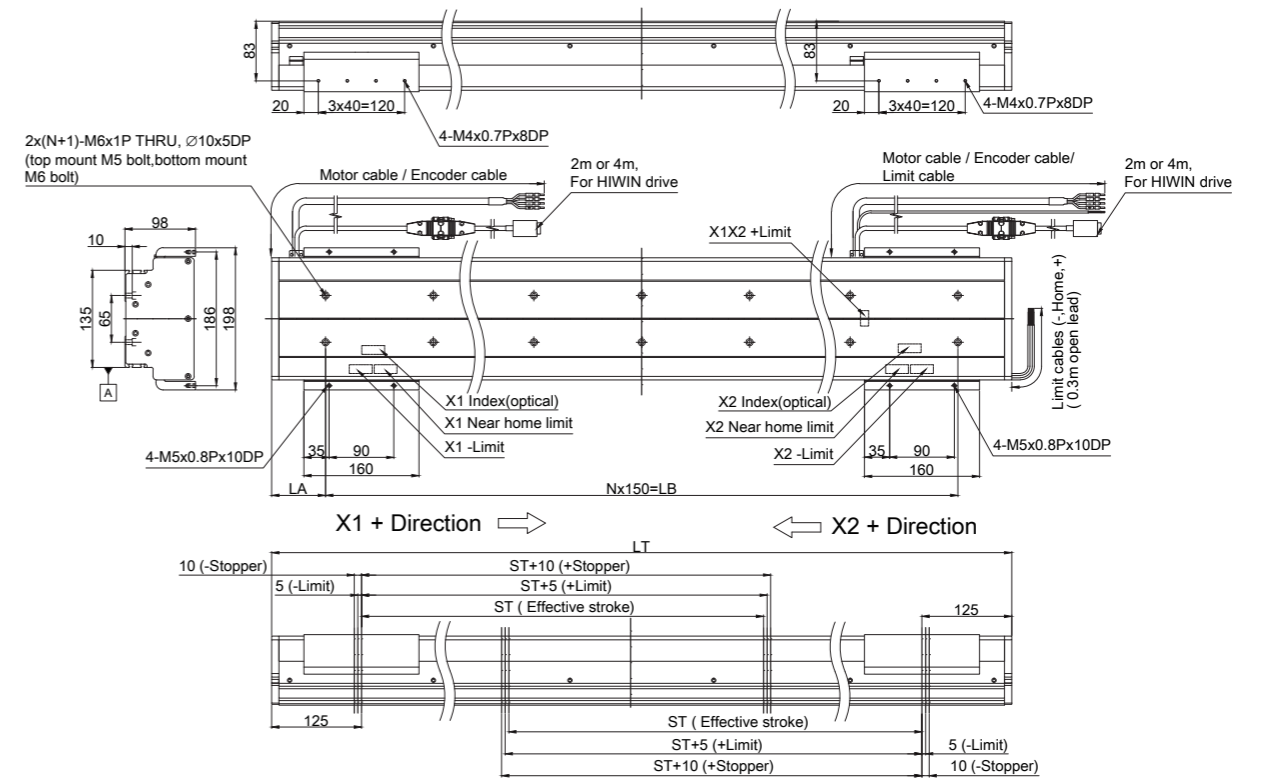

13S100																			
Specification / Effective Stroke	100	150	200	250	300	350	400	450	500	550	600	650	700	750	800	850	900	950	1000
LT	350	400	450	500	550	600	650	700	750	800	850	900	950	1000	1050	1100	1150	1200	1250
N	2	2	2	3	3	3	4	4	4	5	5	5	6	6	6	7	7	7	8
LA	25	50	75	25	50	75	25	50	75	25	50	75	25	50	75	25	50	75	25
LB	300	300	300	450	450	450	600	600	600	750	750	750	900	900	900	1050	1050	1050	1200
Weight	11.4	12.3	13.1	13.8	14.6	15.5	16.3	17.2	18.0	18.7	19.5	20.4	21.2	22.0	22.9	23.6	24.4	25.2	26.1

13S100																				
Specification / Effective Stroke	1050	1100	1150	1200	1250	1300	1400	1500	1600	1700	1800	1900	2000	2100	2200	2300	2400	2500	2600	2700
LT	1300	1350	1400	1450	1500	1550	1650	1750	1850	1950	2050	2150	2250	2350	2450	2550	2650	2750	2850	2950
N	8	8	9	9	9	10	10	11	12	12	13	14	14	15	16	16	17	18	18	19
LA	50	75	25	50	75	25	75	50	25	75	50	25	75	50	25	75	50	25	75	50
LB	1200	1200	1350	1350	1350	1500	1500	1650	1800	1800	1950	2100	2100	2250	2400	2400	2550	2700	2700	2850
Weight	26.9	27.7	28.4	29.3	30.1	30.9	32.6	34.1	35.8	37.5	39	40.7	42.4	43.9	45.6	47.2	48.8	50.4	52.1	53.6

13S100																				
Specification / Effective Stroke	100	150	200	250	300	350	400	450	500	550	600	650	700	750	800	850	900	950	1000	
LT	550	600	650	700	750	800	850	900	950	1000	1050	1100	1150	1200	1250	1300	1350	1400	1450	
N	3	3	4	4	4	5	5	5	6	6	6	7	7	7	8	8	8	9	9	
LA	50	75	25	50	75	25	50	75	25	50	75	25	50	75	25	50	75	25	50	
LB	450	450	600	600	600	750	750	750	900	900	900	1050	1050	1050	1200	1200	1200	1350	1350	
Weight	17.6	18.4	19.2	19.9	20.8	21.6	22.4	23.3	24.1	24.8	25.6	26.5	27.3	28.1	29.0	29.7	30.5	31.3	32.2	

13S100																		
Specification / Effective Stroke	1050	1100	1150	1200	1250	1300	1400	1500	1600	1700	1800	1900	2000	2100	2200	2300	2400	2500
LT	1500	1550	1600	1650	1700	1750	1850	1950	2050	2150	2250	2350	2450	2550	2650	2750	2850	2950
N	9	10	10	10	11	11	12	12	13	14	14	15	16	16	17	18	18	19
LA	75	25	50	75	25	50	25	75	50	25	75	50	25	75	50	25	75	50
LB	1350	1500	1500	1500	1650	1650	1800	1800	35.2	2100	2100	2250	2400	2400	2550	2700	2700	2850
Weight	33.0	33.9	34.5	35.4	36.2	37.1	38.7	40.3	41.9	43.6	45.1	46.8	48.5	50	51.7	53.4	54.9	56.6

Acceleration-Payload Curve

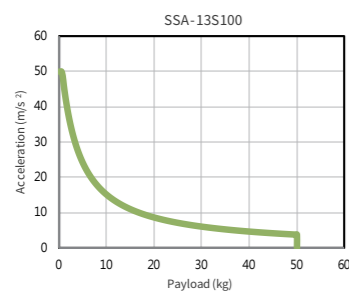

Velocity-Stroke Curve

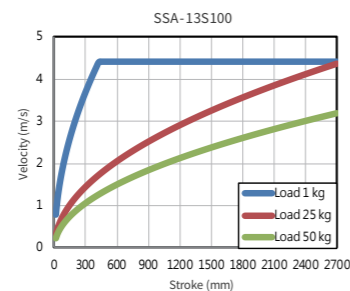

Offset Load Capacity Curve

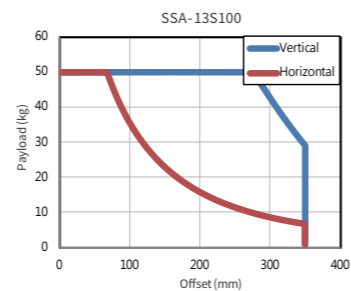

Model Description

LMSSA-13S100-□-□□□□-□□.□□-M-B-A000

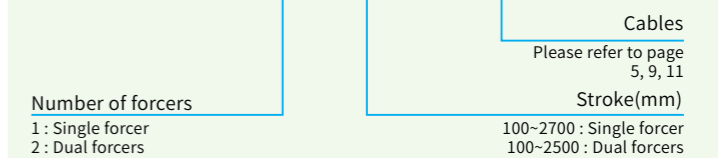

SSA-13 Series Single Forcer

SSA-13S200
S cover Stroke 100~2600

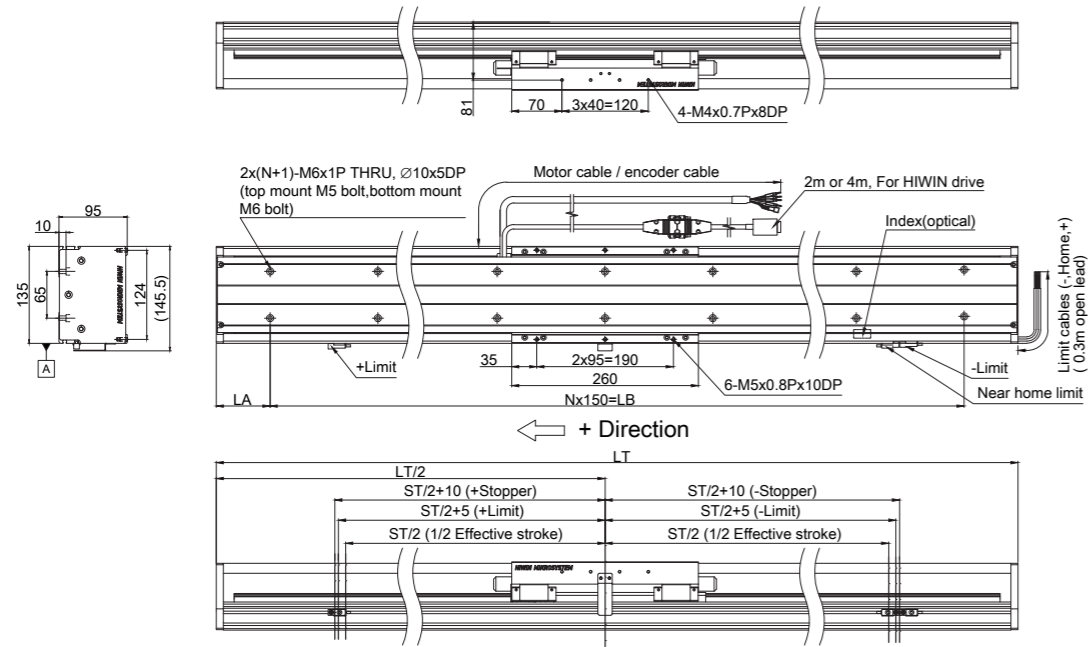

SSA-13 Series Dual Forcers

SSA-13S200
S cover Stroke 100~2300

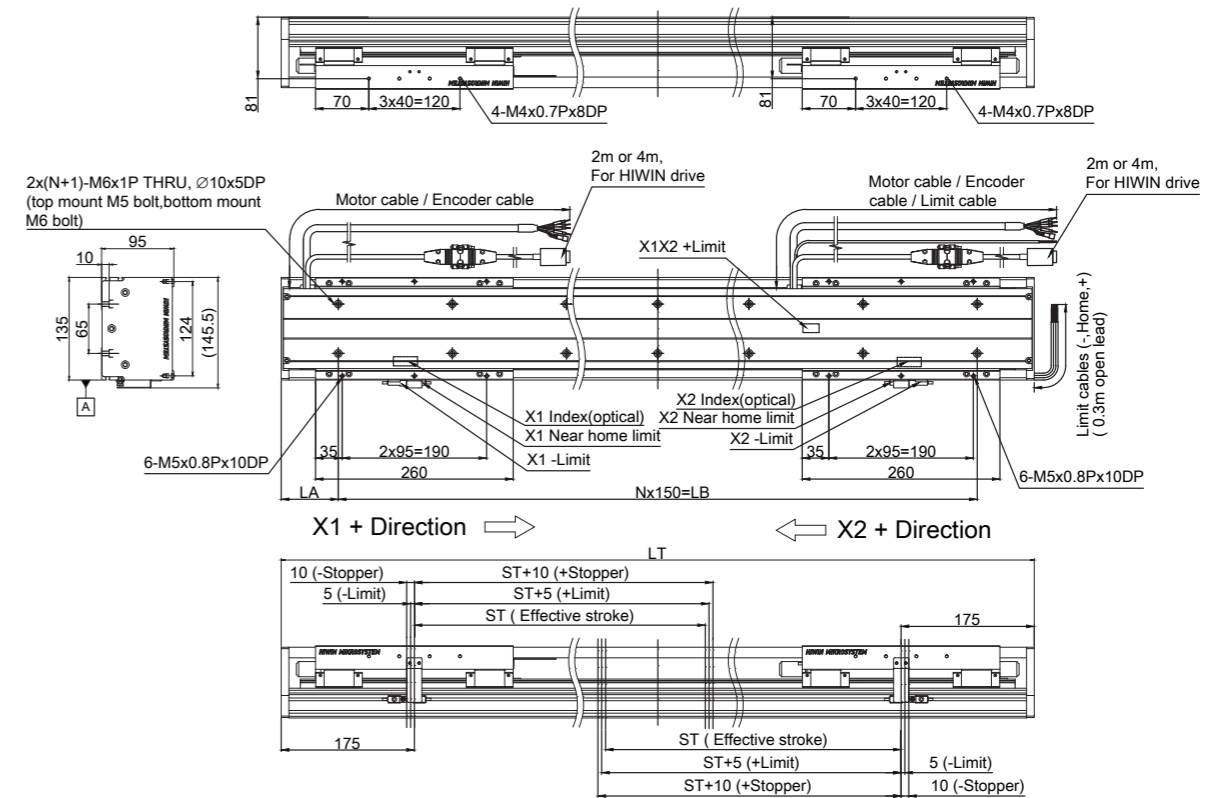

13S200																			
Specification / Effective Stroke	100	150	200	250	300	350	400	450	500	550	600	650	700	750	800	850	900	950	1000
LT	450	500	550	600	650	700	750	800	850	900	950	1000	1050	1100	1150	1200	1250	1300	1350
N	2	3	3	3	4	4	4	5	5	5	6	6	6	7	7	7	8	8	8
LA	75	25	50	75	25	50	75	25	50	75	25	50	75	25	50	75	25	50	75
LB	300	450	450	450	600	600	600	750	750	750	900	900	900	1050	1050	1050	1200	1200	1200
Weight	13.5	14.3	15.0	15.8	16.6	17.4	18.3	19.1	19.7	20.5	21.4	22.2	23.0	23.8	24.5	25.3	26.1	26.9	27.7

13S200																			
Specification / Effective Stroke	1050	1100	1150	1200	1250	1300	1400	1500	1600	1700	1800	1900	2000	2100	2200	2300	2400	2500	2600
LT	1400	1450	1500	1550	1600	1650	1750	1850	1950	2050	2150	2250	2350	2450	2550	2650	2750	2850	2950
N	9	9	9	10	10	10	11	12	12	13	14	14	15	16	16	17	18	18	19
LA	25	50	75	25	50	75	50	25	75	50	25	75	50	25	75	50	25	75	50
LB	1350	1350	1350	1500	1500	1500	1650	1800	1800	1950	2100	2100	2250	2400	2400	2550	2700	2700	2850
Weight	28.5	29.2	30.0	30.8	31.6	32.4	33.9	35.5	37.2	38.6	40.3	41.9	43.4	45	46.6	48.1	49.7	51.4	52.8

13S200																			
Specification / Effective Stroke	100	150	200	250	300	350	400	450	500	550	600	650	700	750	800	850	900	950	1000
LT	750	800	850	900	950	1000	1050	1100	1150	1200	1250	1300	1350	1400	1450	1500	1550	1600	1650
N	4	5	5	5	6	6	6	7	7	7	8	8	8	9	9	9	10	10	10
LA	75	25	50	75	25	50	75	25	50	75	25	50	75	25	50	75	25	50	75
LB	600	750	750	750	900	900	900	1050	1050	1050	1200	1200	1200	1350	1350	1350	1500	1500	1500
Weight	21.8	22.6	23.5	24.3	25.1	25.7	26.6	27.4	28.2	29.0	29.8	30.5	31.3	32.1	32.9	33.7	34.6	35.2	36.0

13S200																
Specification / Effective Stroke	1050	1100	1150	1200	1250	1300	1400	1500	1600	1700	1800	1900	2000	2100	2200	2300
LT	1700	1750	1800	1850	1900	1950	2050	2150	2250	2350	2450	2550	2650	2750	2850	2950
N	11	11	11	12	12	12	13	14	14	15	16	16	17	18	18	19
LA	25	50	75	25	50	75	50	25	75	50	25	75	50	25	75	50
LB	1650	1650	1650	1800	1800	1800	1950	2100	2100	2250	2400	2400	2550	2700	2700	2850
Weight	36.8	37.7	38.5	39.3	40.1	41.1	42.7	44.2	45.8	47.4	48.9	50.6	52.2	53.7	55.3	56.9

Acceleration-Payload Curve

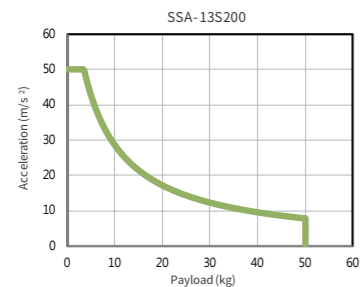

Velocity-Stroke Curve

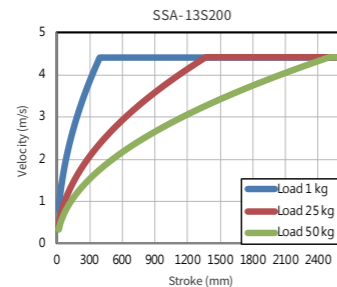

Offset Load Capacity Curve

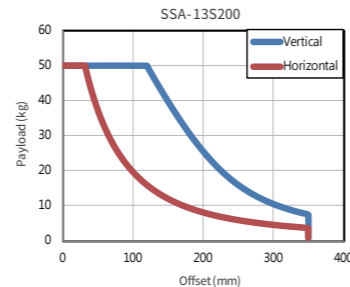

Model Description

LMSSA-13S200-□-□□□□-□□.□□-S-B-A000

Cables
Please refer to page 5, 9, 11

Number of forcers
1: Single forcer
2: Dual forcers

Stroke(mm)
100-2600: Single forcer
100-2300: Dual forcers

SSA-13 Series Single Forcer

SSA-13S300
S cover
Stroke
100~2500

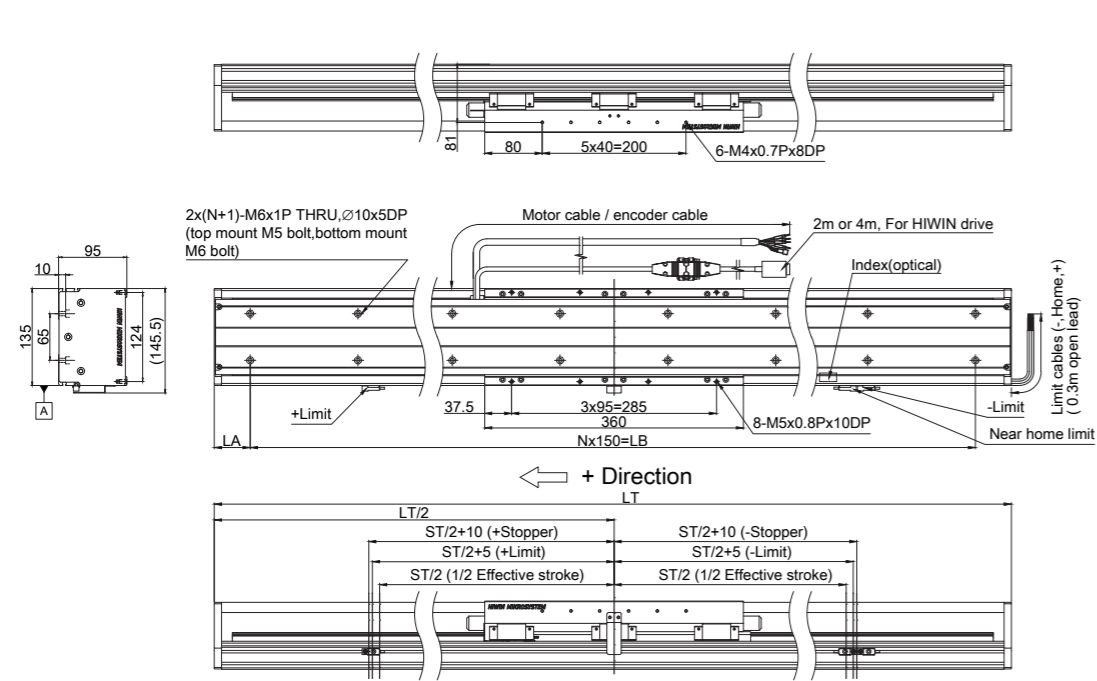

SSA-13 Series Dual Forcers

SSA-13S300
S cover
Stroke
100~2100

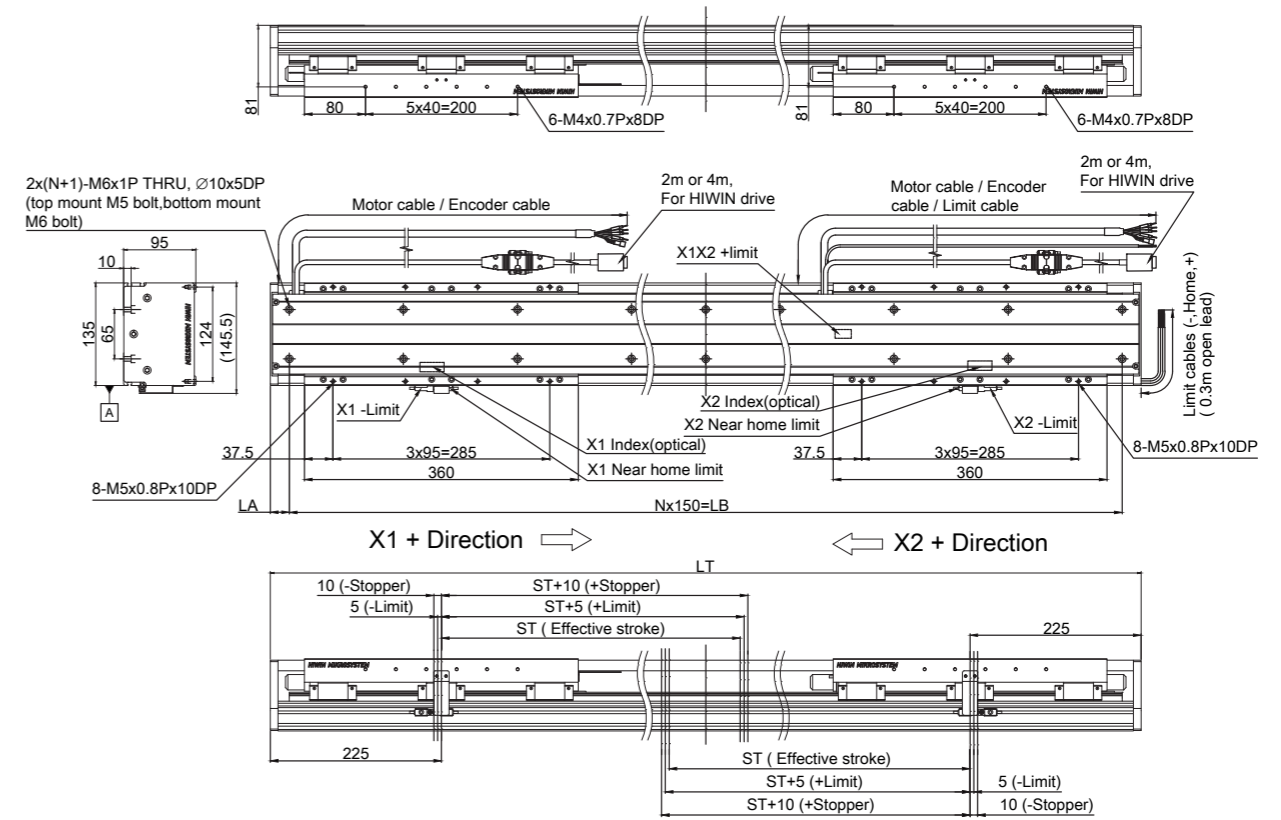

13S300																			
Specification / Effective Stroke	100	150	200	250	300	350	400	450	500	550	600	650	700	750	800	850	900	950	1000
LT	550	600	650	700	750	800	850	900	950	1000	1050	1100	1150	1200	1250	1300	1350	1400	1450
N	3	3	4	4	4	5	5	5	6	6	6	7	7	7	8	8	8	9	9
LA	50	75	25	50	75	25	50	75	25	50	75	25	50	75	25	50	75	25	50
LB	450	450	600	600	600	750	750	750	900	900	900	1050	1050	1050	1200	1200	1200	1350	1350
Weight	16.7	17.5	18.3	19.1	20.0	20.8	21.4	22.2	23.1	23.9	24.7	25.5	26.2	27.0	27.8	28.6	29.4	30.2	30.9

13S300																		
Specification / Effective Stroke	1050	1100	1150	1200	1250	1300	1400	1500	1600	1700	1800	1900	2000	2100	2200	2300	2400	2500
LT	1500	1550	1600	1650	1700	1750	1850	1950	2050	2150	2250	2350	2450	2550	2650	2750	2850	2950
N	9	10	10	10	11	11	12	12	13	14	14	15	16	16	17	18	18	19
LA	75	25	50	75	25	50	25	75	50	25	75	50	25	75	50	25	75	50
LB	1350	1500	1500	1500	1650	1650	1800	1800	1950	2100	2100	2250	2400	2400	2550	2700	2700	2850
Weight	31.7	32.5	33.3	34.1	35.0	35.6	37.2	38.9	40.3	42	43.6	45.1	46.7	48.3	49.8	51.4	53.1	54.5

13S300																			
Specification / Effective Stroke	100	150	200	250	300	350	400	450	500	550	600	650	700	750	800	850	900	950	1000
LT	950	1000	1050	1100	1150	1200	1250	1300	1350	1400	1450	1500	1550	1600	1650	1700	1750	1800	1850
N	6	6	6	7	7	7	8	8	8	9	9	9	10	10	10	11	11	11	12
LA	25	50	75	25	50	75	25	50	75	25	50	75	25	50	75	25	50	75	25
LB	900	900	900	1050	1050	1050	1200	1200	1200	1350	1350	1350	1500	1500	1500	1650	1650	1650	1800
Weight	31.7	32.5	33.3	34.2	35.0	35.9	36.5	37.4	38.2	39.1	39.9	40.7	41.4	42.2	43.1	43.9	44.8	45.6	46.3

13S300														
Specification / Effective Stroke	1050	1100	1150	1200	1250	1300	1400	1500	1600	1700	1800	1900	2000	2100
LT	1900	1950	2000	2050	2100	2150	2250	2350	2450	2550	2650	2750	2850	2950
N	12	12	13	13	13	14	14	15	16	16	17	18	18	19
LA	50	75	25	50	75	25	75	50	25	75	50	25	75	50
LB	1800	1800	1950	1950	1950	2100	2100	2250	2400	2550	2700	2700	2700	2850
Weight	47.1	48.0	48.8	49.6	50.5	51.2	52.8	54.5	56	57.7	59.4	60.9	62.6	64.3

Acceleration-Payload Curve

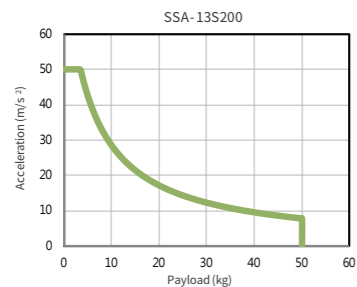

Velocity-Stroke Curve

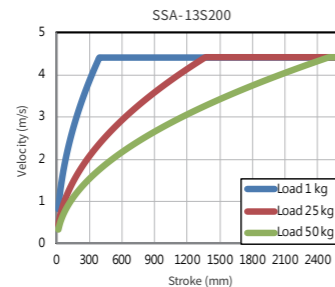

Offset Load Capacity Curve

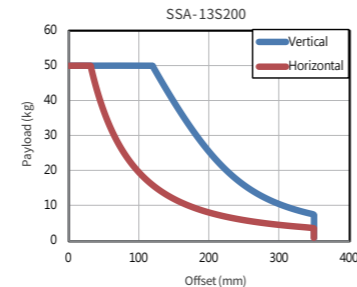

Model Description

LMSSA-13S300-□-□□□□-□□.□□-S-B-A000

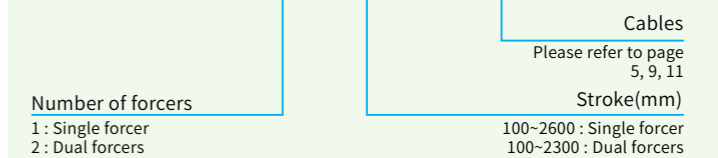

SSA-13 Series Single Forcer

SSA-13S300
M cover Stroke 100~2500

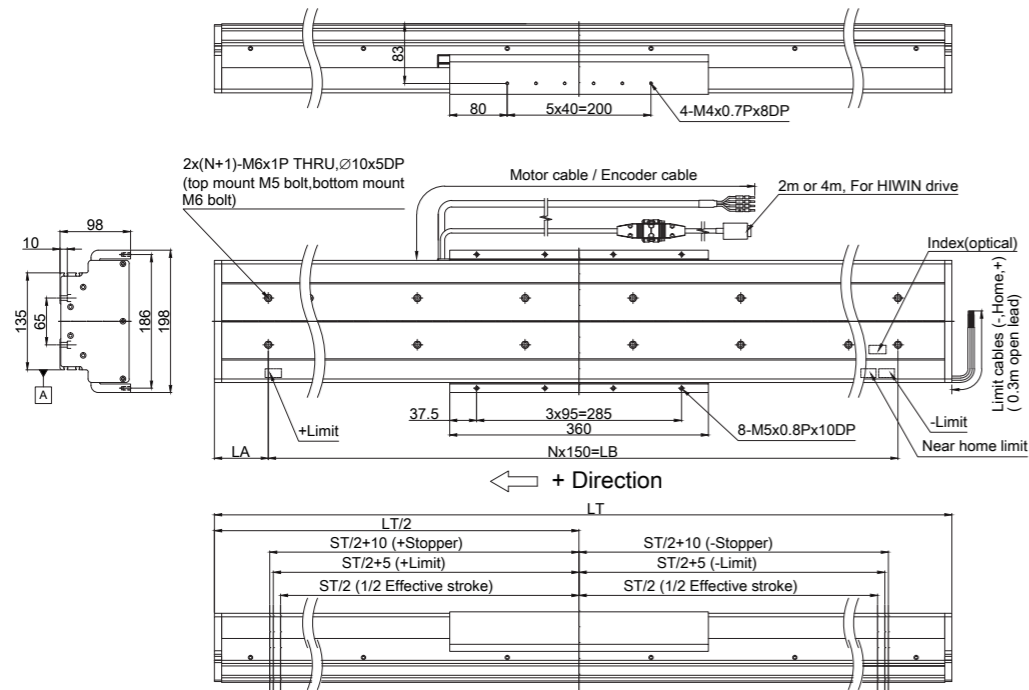

13S300																			
Specification / Effective Stroke	100	150	200	250	300	350	400	450	500	550	600	650	700	750	800	850	900	950	1000
LT	550	600	650	700	750	800	850	900	950	1000	1050	1100	1150	1200	1250	1300	1350	1400	1450
N	3	3	4	4	4	5	5	5	6	6	6	7	7	7	8	8	8	9	9
LA	50	75	25	50	75	25	50	75	25	50	75	25	50	75	25	50	75	25	50
LB	450	450	600	600	600	750	750	750	900	900	900	1050	1050	1050	1200	1200	1200	1350	1350
Weight	18.7	19.6	20.4	21.3	22.1	22.9	23.6	24.5	25.3	26.1	27.0	27.8	28.5	29.3	30.2	31.0	31.8	32.7	33.4

13S300																		
Specification / Effective Stroke	1050	1100	1150	1200	1250	1300	1400	1500	1600	1700	1800	1900	2000	2100	2200	2300	2400	2500
LT	1500	1550	1600	1650	1700	1750	1850	1950	2050	2150	2250	2350	2450	2550	2650	2750	2850	2950
N	9	10	10	10	11	11	12	12	13	14	14	15	16	16	17	18	18	19
LA	75	25	50	75	25	50	25	75	50	25	75	50	25	75	50	25	75	50
LB	1350	1500	1500	1500	1650	1650	1800	1800	1950	2100	2100	2250	2400	2400	2550	2700	2700	2850
Weight	34.2	35.0	35.9	36.7	37.6	38.2	39.9	41.6	43.1	44.8	46.5	48	49.7	51.3	52.9	54.5	56.2	57.7

Acceleration-Payload Curve

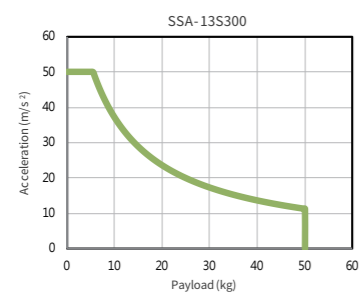

Velocity-Stroke Curve

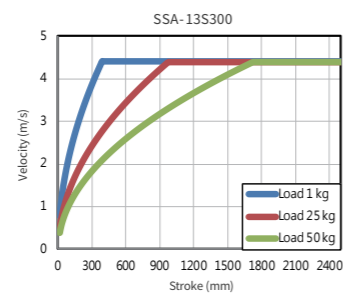

Offset Load Capacity Curve

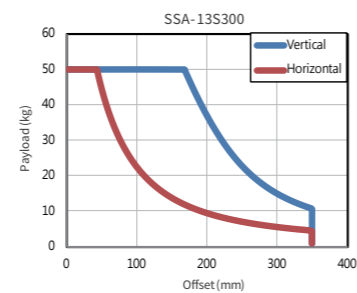

SSA-13 Series Dual Forcers

SSA-13S300
M cover Stroke 100~2100

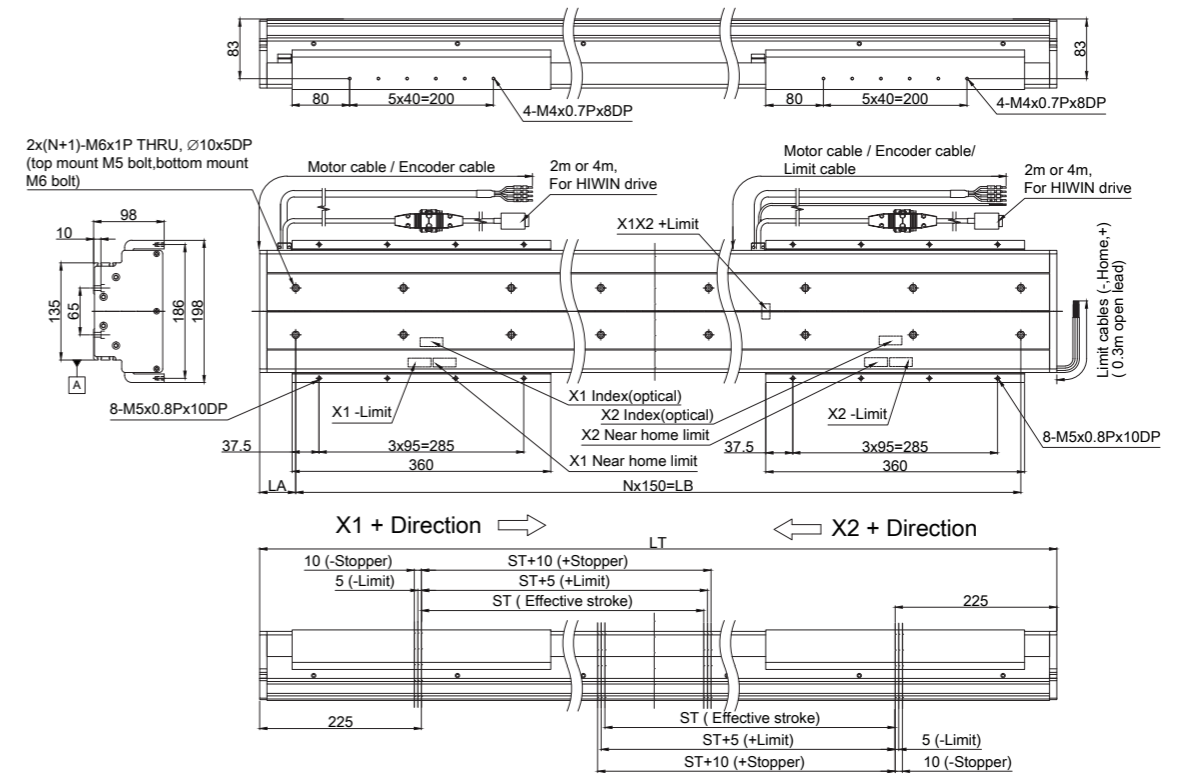

13S300																			
Specification / Effective Stroke	100	150	200	250	300	350	400	450	500	550	600	650	700	750	800	850	900	950	1000
LT	950	1000	1050	1100	1150	1200	1250	1300	1350	1400	1450	1500	1550	1600	1650	1700	1750	1800	1850
N	6	6	6	7	7	7	8	8	8	9	9	9	10	10	10	11	11	11	12
LA	25	50	75	25	50	75	25	50	75	25	50	75	25	50	75	25	50	75	25
LB	900	900	900	1050	1050	1050	1200	1200	1200	1350	1350	1350	1500	1500	1500	1650	1650	1650	1800
Weight	31.7	32.5	33.3	34.2	35.0	35.9	36.5	37.4	38.2	39.1	39.9	40.7	41.4	42.2	43.1	43.9	44.8	45.6	46.3

13S300																
Specification / Effective Stroke	1050	1100	1150	1200	1250	1300	1400	1500	1600	1700	1800	1900	2000	2100		
LT	1900	1950	2000	2050	2100	2150	2250	2350	2450	2550	2650	2750	2850	2950		
N	12	12	13	13	13	14	14	15	16	16	17	18	18	19		
LA	50	75	25	50	75	25	75	50	25	75	50	25	75	50		
LB	1800	1800	1950	1950	1950	2100	2100	2250	2400	2400	2550	2700	2700	2850		
Weight	47.1	48.0	48.8	49.6	50.5	51.2	52.8	54.5	56	57.7	59.4	60.9	62.6	64.3		

Model Description

LMSSA-13S300-□-□□□□-□□.□□-M-B-A000

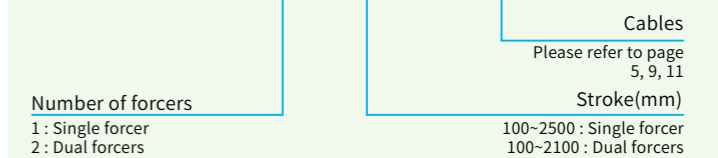

SSA-20 Series Single Forcer

SSA-20S700
S cover
Stroke
100~2400

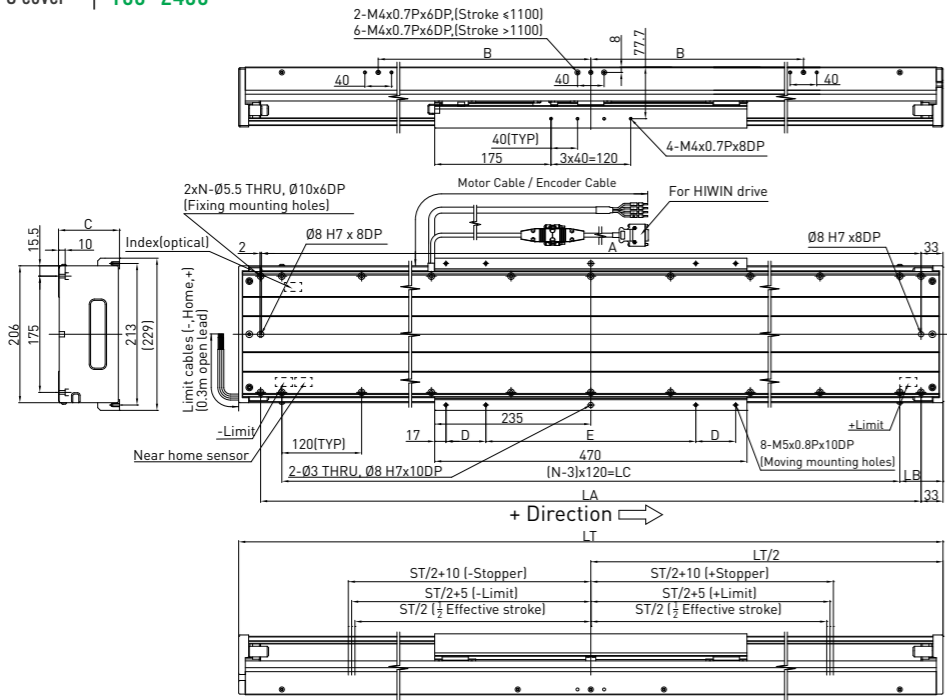

SSA-20 Series Dual Forcers

SSA-20S700
S cover
Stroke
100~1800

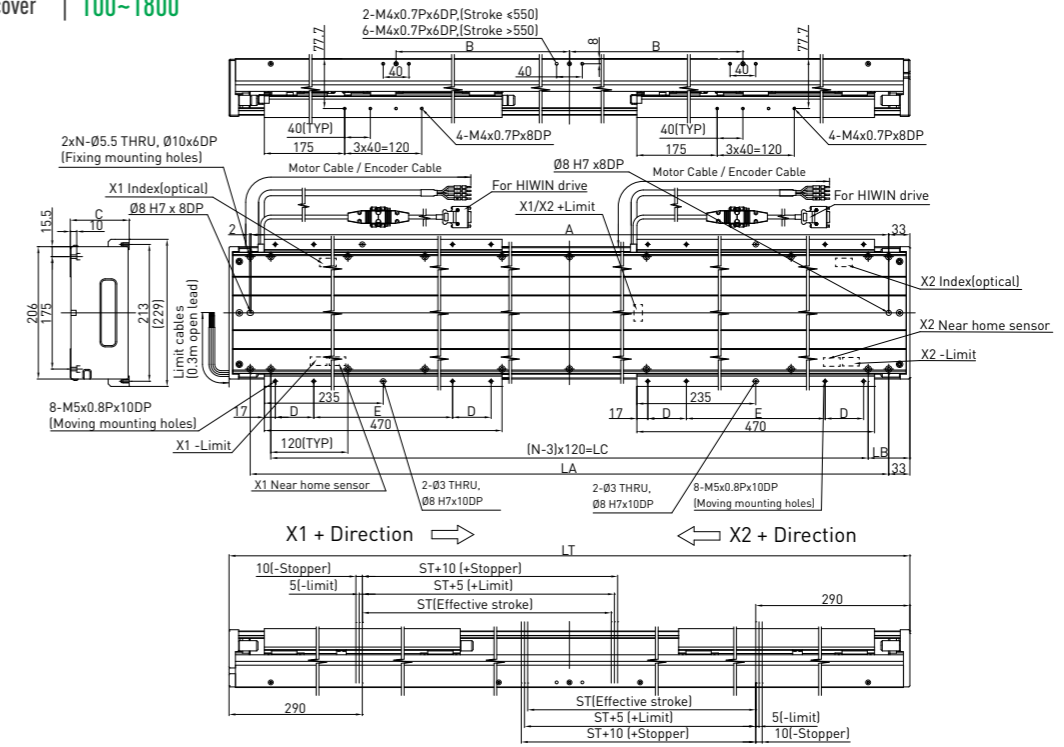

20S700		100	150	200	250	300	350	400	450	500	550	600	650	700	750	800	850	900	950	1000	
Specification / Effective Stroke	LT	680	730	780	830	880	930	980	1030	1080	1130	1180	1230	1280	1330	1380	1430	1480	1530	1580	
	N	7	7	7	9	9	9	9	11	11	11	11	11	13	13	13	15	15	15	15	
	LA	614	664	714	764	814	864	914	964	1014	1064	1114	1164	1214	1264	1314	1364	1414	1464	1514	
	LB	100	125	150	55	80	105	130	155	60	85	110	135	160	65	90	115	20	45	70	
	LC	480	480	480	720	720	720	720	960	960	960	960	960	1200	1200	1200	1440	1440	1440	1440	
	A	613	663	713	763	813	863	913	963	1013	1063	1113	1163	1213	1263	1313	1363	1413	1463	1513	
	B	-	-	-	-	-	-	-	-	-	-	-	-	-	-	-	-	-	-	-	
	C	91.7																			
	D	60										111.7									
	E	316										120									
	Weight	25.1	26.3	27.4	28.5	29.7	30.8	32	33.1	34.3	35.4	36.6	37.7	38.9	40	41.2	42.3	43.5	44.6	45.8	

20S700		100	150	200	250	300	350	400	450	500	550	600	650	700	750	800	850	900	950	1000	
Specification	Effective Stroke	140	190	240	290	340	390	440	490	540	590	640	690	740	790	840	890	940	990	1040	
	LT	1230	1280	1330	1380	1430	1480	1530	1580	1630	1680	1730	1780	1830	1880	1930	1980	2030	2080	2130	
	N	11	13	13	13	13	15	15	15	15	15	15	17	17	17	17	17	19	19	19	
	LA	1164	1214	1264	1314	1364	1414	1464	1514	1564	1614	1664	1714	1764	1814	1864	1914	1964	2014	2064	
	LB	160	40	65	90	115	20	45	70	95	120	145	50	75	100	125	150	55	80	105	
	LC	960	1200	1200	1200	1200	1440	1440	1440	1440	1440	1440	1680	1680	1680	1680	1680	1920	1920	1920	
	A	1163	1213	1263	1313	1363	1413	1463	1513	1563	1613	1663	1713	1763	1813	1863	1913	1963	2013	2063	
	B	-	-	-	-	-	-	-	-	-	-	600	600	600	600	600	600	600	600	600	
	C	91.7										111.7									
	D	60										120									
	E	316										196									
	Weight	48.2	49.4	50.5	51.7	52.8	54.0	55.1	56.3	57.4	58.6	59.7	60.9	62.0	63.2	64.3	65.5	66.6	67.8	69.0	

20S700		1050	1100	1150	1200	1250	1300	1400	1500	1600	1700	1800	1900	2000	2100	2200	2300	2400	
Specification / Effective Stroke	LT	1630	1680	1730	1780	1830	1880	1980	2080	2180	2280	2380	2480	2580	2680	2780	2880	2980	
	N	15	15	15	17	17	17	17	19	19	21	21	21	23	25	25	25	27	
	LA	1564	1614	1664	1714	1764	1814	1914	2014	2114	2214	2314	2414	2514	2614	2714	2814	2914	
	LB	95	120	145	50	75	100	150	80	130	60	110	160	90	20	70	120	50	
	LC	1440	1440	1440	1680	1680	1680	1680	1920	1920	2160	2160	2160	2400	2640	2640	2640	2880	
	A	1563	1613	1663	1713	1763	1813	1913	2013	2113	2213	2313	2413	2513	2613	2713	2813	2913	
	B	-	-	600	600	600	600	600	840	840	840	840	840	1080	1080	1080	1080	1080	
	C	91.7										111.7							
	D	60										120							
	E	316										196							
	Weight	46.9	48.1	49.2	50.4	51.5	52.7	55	60.3	62.6	64.9	67.2	69.5	71.8	74.1	76.4	78.7	81	

20S700		1050	1100	1150	1200	1250	1300	1400	1500	1600	1700	1800
Specification	Effective Stroke	1090	1140	1190	1240	1290	1340	1440	1540	1640	1740	1840
	LT	2180	2230	2280	2330	2380	2430	2530	2630	2730	2830	2930
	N	19	19	21	21	21	21	23	23	25	25	25
	LA	2114	2164	2214	2264	2314	2364	2464	2564	2664	2764	2864
	LB	130	155	60	85	110	135	65	115	45	95	145
	LC	1920	1920	2160	2160	2160	2160	2400	2400	2640	2640	2640
	A	2113	2163	2213	2263	2313	2363	2463	2563	2663	2763	2863
	B	840	840	840	840	840	840	840	840	1080	1080	1080
	C	111.7										
	D	120										
	E	196										
	Weight	74.1	75.2	76.4	77.5	78.6	79.8	82.1	84.4	86.7	89.0	91.3

Acceleration-Payload Curve

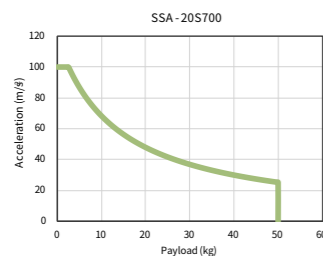

Velocity-Stroke Curve

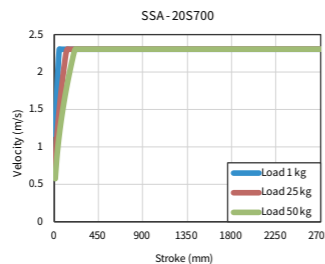

Offset Load Capacity Curve

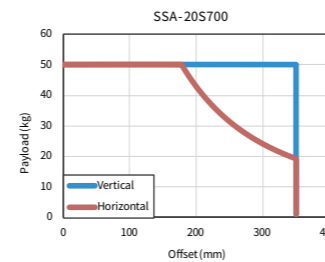

Model Description

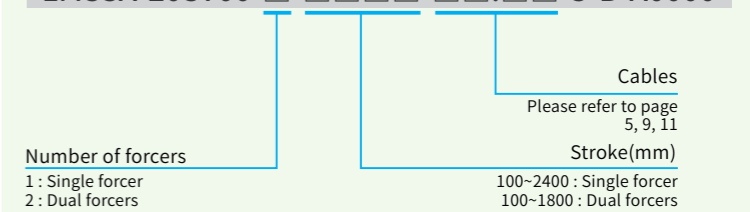

LMSSA-20S700-□-□□□□-□□.□□-S-B-A000



Drive

Drive

The advantages and selection suggestions of drive

Type	D2T-LM 	D1 	E1 
Continuous Current(Arms)	5.1	8.5	12
Selection Suggestions	Simple and Basic Operation	High Current (Force), the Application of Analog Signal	High Dynamic Response, Ripple Compensation and Gantry Control
Features	EtherCAT / mega-ulink	●	●
	MECHATROLINK III		●
	Supports Digital Encoder Signal	●	●
	Supports Analog Encoder Signal		●
	Supports Absolute Encoder Signal		
	Supports Hall Encoder		●
	Error Mapping	●	●
	Vibration Suppression Function	●	●
	Optimized Closed-Loop Frequency Response	●	●
	Programmable PDL	●	●
	Hall Sensor		●
	Temperature Detection and Control Function		●
	High Acceleration & Deceleration / Fast Settling Time		
	Position Trigger (PT)		
	Safe Torque OFF Function		
	Ripple Compensation		
Gantry Structure			

Note:
1. Excellent Smart Cube (ESC) is required.

E1 Drive

- 3.2 kHz speed response
- Tuneless function
- Advanced auto tuning
- Ripple compensation
- Unique gantry control function
- Network with industrial communication devices
- Supports various motor types
- Built-in STO function
- Supports various types of encoders, such as Digital, Analog, Tamagawa, EnDat and BiSS-C



1 Higher Accuracy

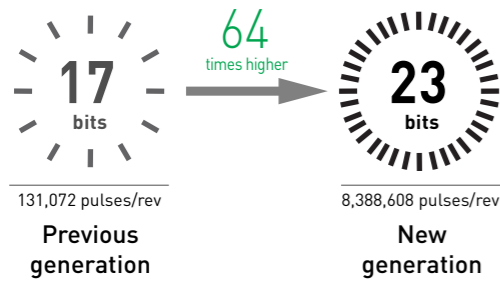

2 3.2kHz Speed Response

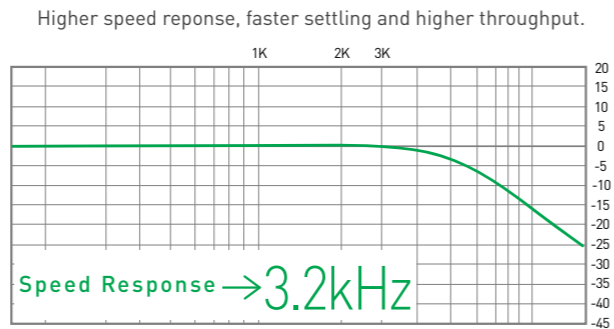

3 Advanced Auto-Tune Function

This function supports automatic loop gains tuning and filters adjustment to suppress mechanical vibration and resonance, which optimizes machine performance.

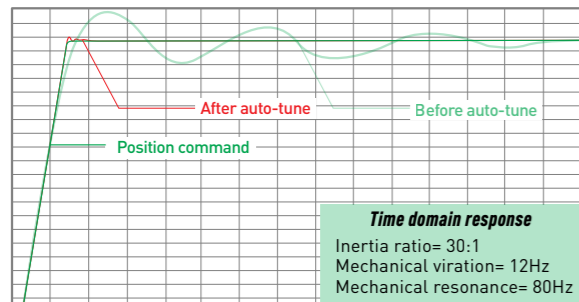

4 Ripple Compensation

Effectively suppresses the speed ripple caused by motor cogging. This function is especially useful for mechanism in which high control gains are not allowed.

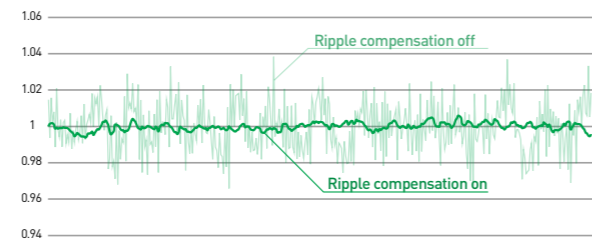

5 Unique Gantry Application

With the connection of two E1 drives, the linear and yawing movement of a gantry can be easily optimized.

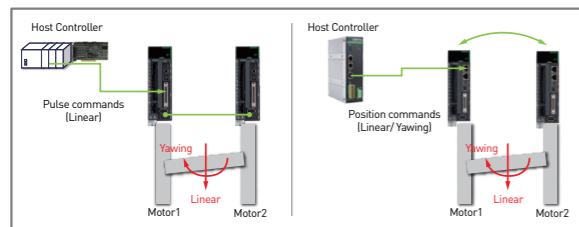

6 Compatible Encoder

Built-in interface to receive digital encoder signals. Tamagawa serial encoder interface is also supported. With an ESC(Excellent Smart Cube), E1 can support other types of encoders, such as analog (SIN/COS), EnDat and BiSS-C.

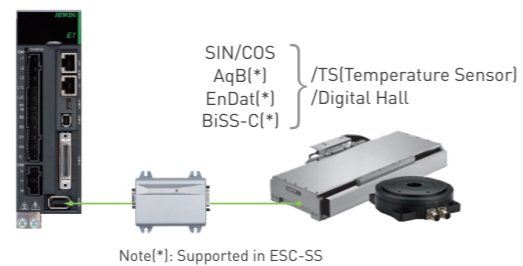

Model Description

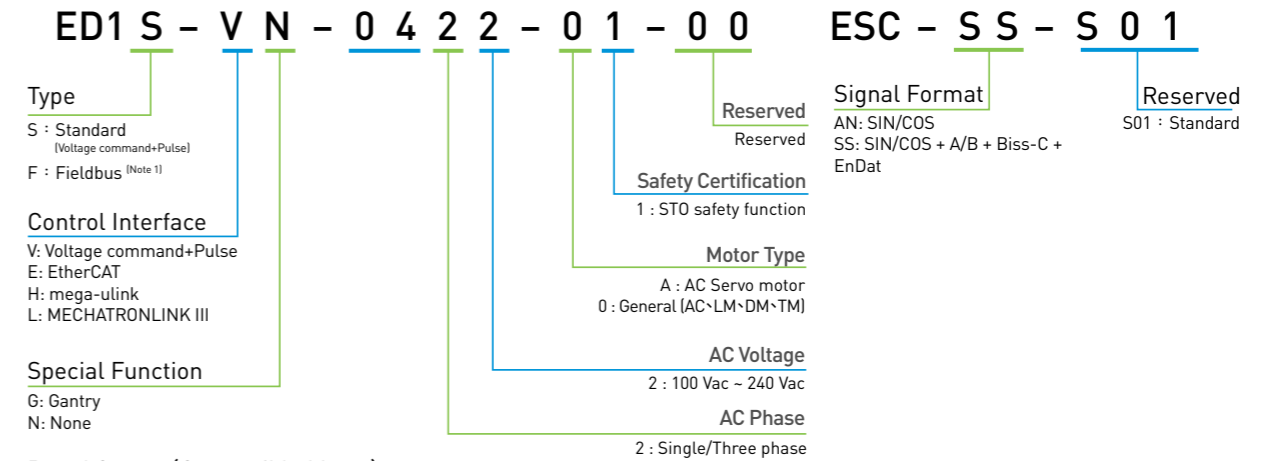

Rated Output (Compatible Motor)

- 04: 400W (08S050, 10S100, 13S100, 18S100, 20C100, 20C200)
- 10: 1kW (08S100, 10S200, 13S200, 18S200, 18C100, 18C200, 20S300)
- 12: 1.2kW (13S300, 18S300, 20S500, 20S700)

Note:
 1. EtherCAT, mega-ulink and MECHATROLINK III are fieldbus system.
 2. Model code can be generated via the sizing program on our website (<https://w3.hiwinmikro.tw/hiwincal.aspx>).

Wiring Diagram

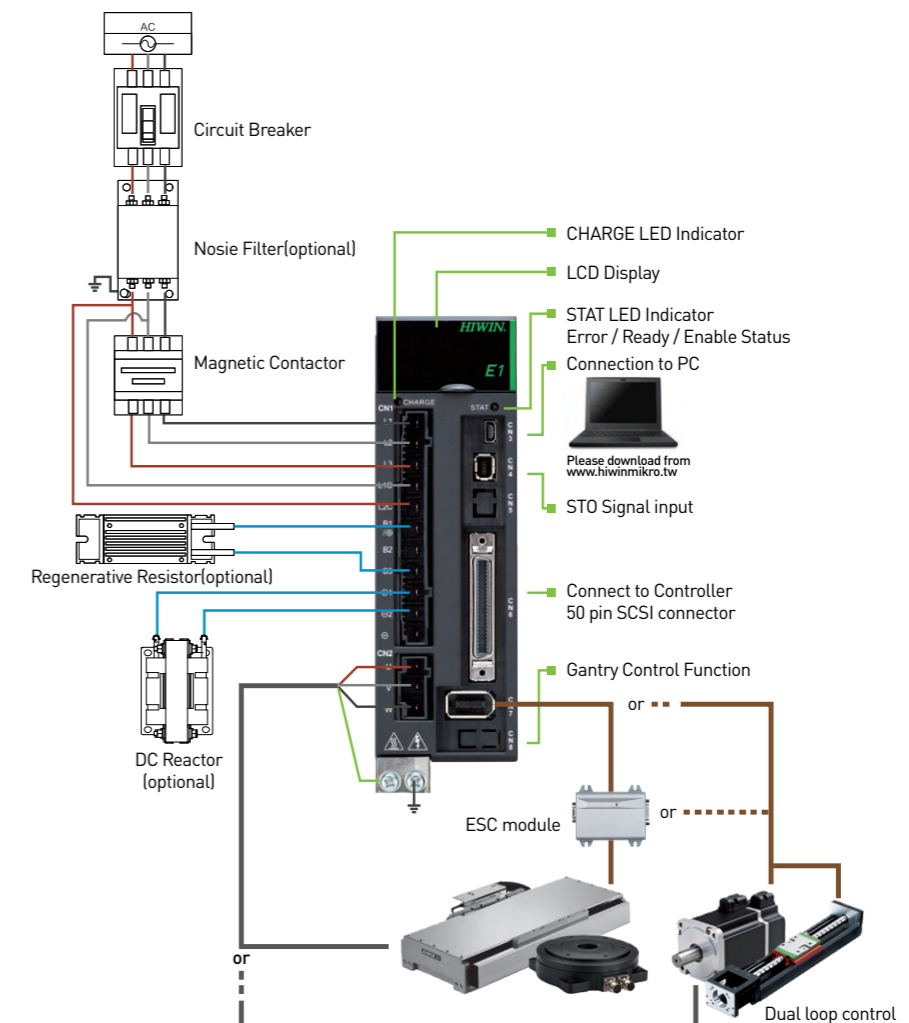

400W

Standard

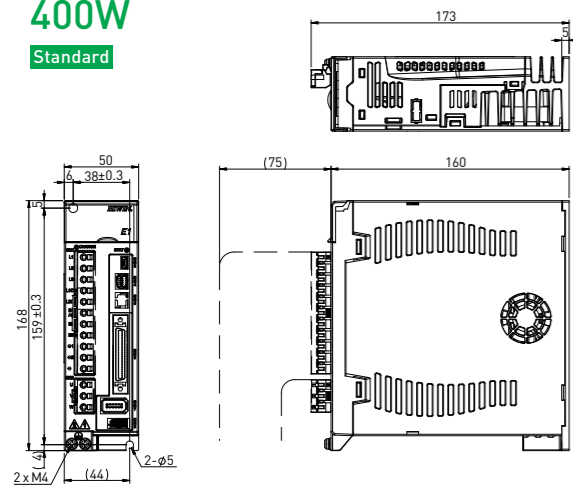

Fieldbus

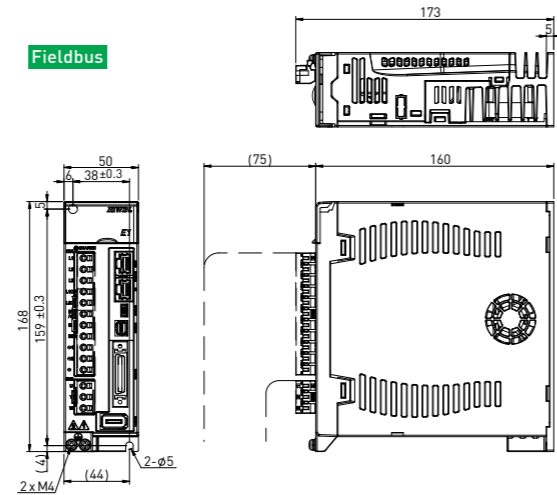

1kW/1.2kW

Standard

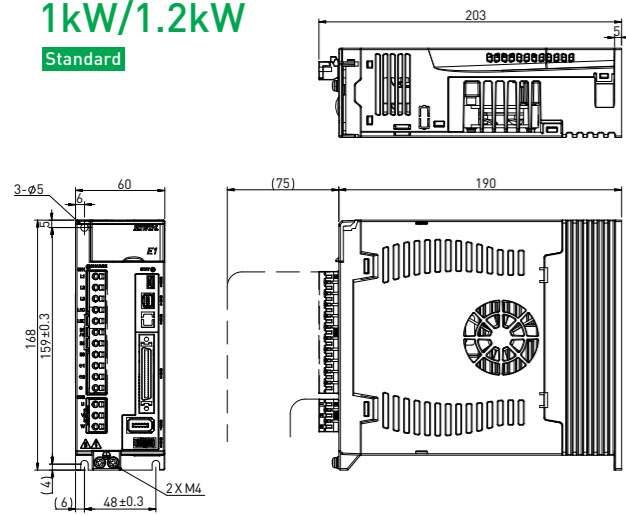

Fieldbus

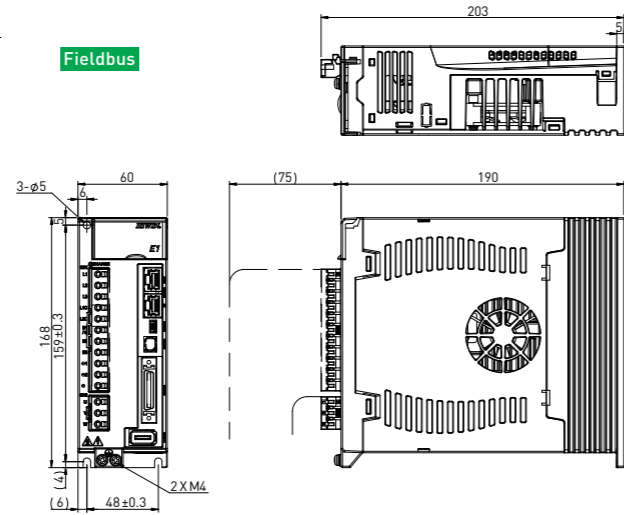

ESC Hardware



Excellent Smart Cube(ESC)

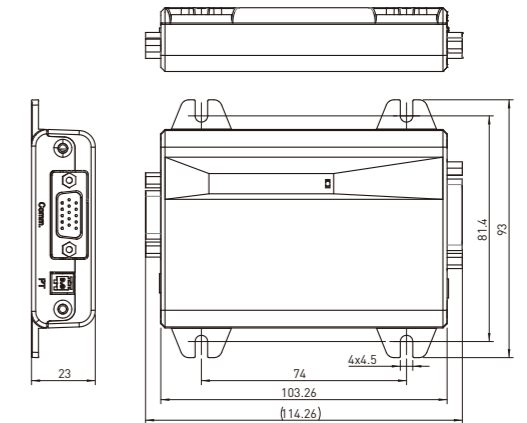

Item	Specification					
Max. Output Voltage	+5.0 V ±5%					
Max. Output Current	650mA					
Encoder Type	Digital Hall Sensor	Incremental Sign		Absolute Type		
	Hall U/ V/ W	SIN / COS / Reference	A/ B/ Index	BiSS-C	Tamagawa	EnDat 2.1 / 2.2
Signal Bandwidth	2kHz	1 MHz (multiplier factor : 4096 times)	4MHz	5MHz	5MHz	4MHz
Max. Resolution	-	-	-	Differential signal (RS485)		
Input Signal Format	5V CMOS / TTL	Differential (RS422)		Differential (RS485)		
Over-Temperature Protection	PTC					
Ambient Temperature	0°C to + 45°C					
Storage Temperature	-20°C to + 65°C					
IP Rating	IP20					

Name	HIWIN Part Number	Description
ESC encoder communication cable.	HE00EJUDA100	ESC to E1 drive encoder communication port

E1 Specification

Rated Output		400 W	1 kW	1.2 kW	
Input Power	Single Phase Main Power	Rated Voltage (Line to Line)	AC 100 ~ 120 Vrms, 50~60 Hz AC 200 ~ 240 Vrms, 50~60 Hz		
		Rated Current (Arms)	2.9	6.5	11.1
	Three Phase Main Power	Rated Voltage (Line to Line)	AC 200 ~ 240 Vrms, 50~60 Hz		
		Rated Current (Arms)	1.46	3.3	5.78
Control Power		1 Ø/AC 100 ~ 120 Vrms, 50~60 Hz 1 Ø/AC 200 ~ 240 Vrms, 50~60 Hz			
Output Power	Phase Voltage		3 Ø/AC 240 Vrms max.		
	Max Rated Power (W)		400	1 k	1.2 k
	Peak Current (Arms)		10	23.3	23.3
	Rated Current (Arms)		2.5	5.6	9
Cooling Method		Fan cooling			
Control Method		IGBT PWM space vector control			
PWM Modulation Frequency		16 kHz		8 kHz	
Applicable Motor		AC/DM/LM (Depending on encoder type, Excellent Smart Cube (ESC) may be required.)			
STAT LED Indicator		<ul style="list-style-type: none"> Blinking red: Error Blinking green: Ready Green: Enabled There is no STAT LED indicator on Fieldbus servo drive. 			
CHARGE LED Indicator		<ul style="list-style-type: none"> Red: The main power is supplied. No light: The main power is not supplied. 			
Dynamic Brake		<ul style="list-style-type: none"> Built-in dynamic brake circuit 400 W: no built-in dynamic brake resistor Delay time of relay: 20 ms 			
Built-in Resistor for Dynamic Brake		-	10 Ohm /10 W		
Analog Output		<ul style="list-style-type: none"> Channel: 2 Resolution: 12 bit Output voltage range: ±10 V Accuracy: ±2% Maximum output current: ±10 mA 			
Control Function	Position Mode	Command Source		Pulse command from controller	
		Signal Type		<ul style="list-style-type: none"> Pulse/Direction CW/CCW AqB 	
		Isolated Circuit		High-speed optical coupler	
		Input Signal		Differential input (2.8 V ≤ high and low potential difference ≤ 3.7 V) or single-ended input(12~24 VDC)	
		Maximum Input Bandwidth		<ul style="list-style-type: none"> Differential: 5 Mpps Single-ended: 200 kpps 	
		Electronic Gear		Gear ratio: pulses/counts Pulses: 1~1,073,741,824 Counts: 1~1,073,741,824	
	Velocity Mode	Command Source		DC voltage command from controller	
		Analog Input	Impedance	14 kOhm	
			Signal Format	±10 Vdc	
			Maximum Input Bandwidth	100 Hz	
			Specification	16 bit A/D input (V-REF+/-)	
		Command Source		DC voltage command from controller	
		Torque Mode	Analog Input	Impedance	14 kOhm
				Signal Format	±10 Vdc
	Maximum Input Bandwidth			100 Hz	
	Specification			16 bit A/D input (T-REF+/-)	
Control Mode		<ol style="list-style-type: none"> Position mode Velocity mode Torque mode Full-closed loop mode (Dual loop mode) 			

Rated Output		400 W	1 kW	1.2 kW
Encoder	Power Supply		+5.1 Vdc ±5%, 700 mA	
	Signal Format	Serial signal	Resolution: 23 bit (Single-turn/multi-turn absolute encoder) Bandwidth: 5 MHz	
		Incremental signal (Digital differential TTL signal)	AqB and Z-phase signals The maximum input bandwidth of each phase is 5 MHz. Quadruple frequency, 20 Mcounts/s	
	Safety Function		<ul style="list-style-type: none"> Encoder power malfunction detection Short circuit protection Undervoltage protection Overvoltage protection Encoder alarm protection (Digital differential TTL signal) 	
	Position Counting Range		Short circuit protection	
	Linear Motor / Direct Drive Motor		Undervoltage protection	
Encoder Feedback	Emulated Encoder Output (Fieldbus servo drive does not support)	Z Phase	<ol style="list-style-type: none"> Serial encoder and incremental encoder (AqB、sin/cos) are supported. The width of output signal can be adjusted by parameter. Digital differential signal output Z-phase open collector output is supported. Two output methods can be selected. <ul style="list-style-type: none"> Only outputs one Z-phase signal for total travel distance. Outputs one Z-phase signal per one revolution. 	
		A / B Phase	<ol style="list-style-type: none"> Serial encoder and digital encoder (AqB) are supported. Differential signal output. The maximum output bandwidth is 18 Mcount/s. The scaling of output can be adjusted. For instance, ten encoder counts = one emulated encoder count. 	
	Buffered Encoder Output	Z Phase	<ol style="list-style-type: none"> Only supports digital encoder (AqB). Differential signal output Supports Z phase open-collector output. 	
		A / B Phase	<ol style="list-style-type: none"> Only supports digital encoders (AqB). Differential signal output, maximum output bandwidth 20 Mcount/s. 	
Computer Communication	Standard USB2.0 (Mini USB type)		Connect the servo drive with your computer to set parameters, monitor physical quantities and execute trial operation via Thunder.	
General-purpose I/O	Input		The functions of general-purpose inputs (Optical couplers) can be defined by users. E1 series servo drive provides ten general-purpose inputs (I1 to I10). Fieldbus servo drive only provides eight general-purpose inputs (I1 to I8) 24 V/5 mA (Each input pin)	
	Output		The functions of general-purpose outputs (Optical couplers) can be defined by users. E1 series servo drive provides five general-purpose outputs (O1 to O5) 24 V/0.1 A (Each output pin)	
	Position Trigger (PT)		The pins for position trigger (PT) output function are CN6-46 and 47 (Differential signal). Differential 3.3 V, maximum current 20 mA, maximum output bandwidth 10 MHz.	
Regenerative Energy Protection	Regenerative Resistor		<ul style="list-style-type: none"> 400 W: Without built-in regenerative resistor Connect to external regenerative resistor if needed. 1 kW/1.2 kW: With built-in regenerative resistor. Connect to external regenerative resistor to increase regenerative capacity. 	
	Built-in Regenerative Resistor		-	40 Ohm / 40 W
	Power Capacity [uF]		820	1410
	Protection of Regenerative Resistor Enabled		+HV → 370 Vdc	
	Protection of Regenerative Resistor Disabled		+HV ← 360 Vdc	
	Overvoltage Protection		390 Vdc	
Optional Function		Gantry synchronization control function		
Environment	Operating Temperature		0~45 oC	
	Storage Temperature		-20 oC~65 oC	
	Humidity		Operating and storage temperature: 20 to 85% RH (Non-condensing)	
	Altitude		Altitude 1,000 M or lower above sea level	
	Vibrating		Less than 0.5 G, Frequency 10 to 500 Hz, No continuous use under resonance frequency	
	IP Rating		IP20	

D1 Drive

- 100-240 VAC power input
- Supports STP/DIR, CW/CCW, A/B pulse formats (differential/single-ended interface)
- Supports ±10V voltage or digital commands for velocity or force / torque modes
- Built-in function of error compensation, vibration suppression



Optimization Tool

D1 provides powerful and easy-to-use optimization tools. A user can use the closed-loop frequency response function and real-time response graph will be displayed on the PC. The best gain values of the system can be set easily according to the response graph.

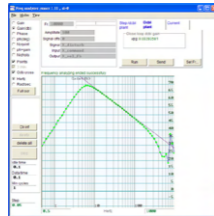

Analog Encoder Can Work with Resolution Units Smaller than Nanometer

When using an analog encoder, a user is allowed to set the resolution to very small units. D1 is able to realize precise control based on units smaller than nanometer.

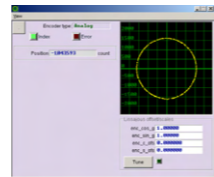

Error Mapping

D1 drive supports error mapping to encoder feedback and compensation table building, which contains up to 16,000 points. With this function, the positioning accuracy of the system can be optimized in any control mode.

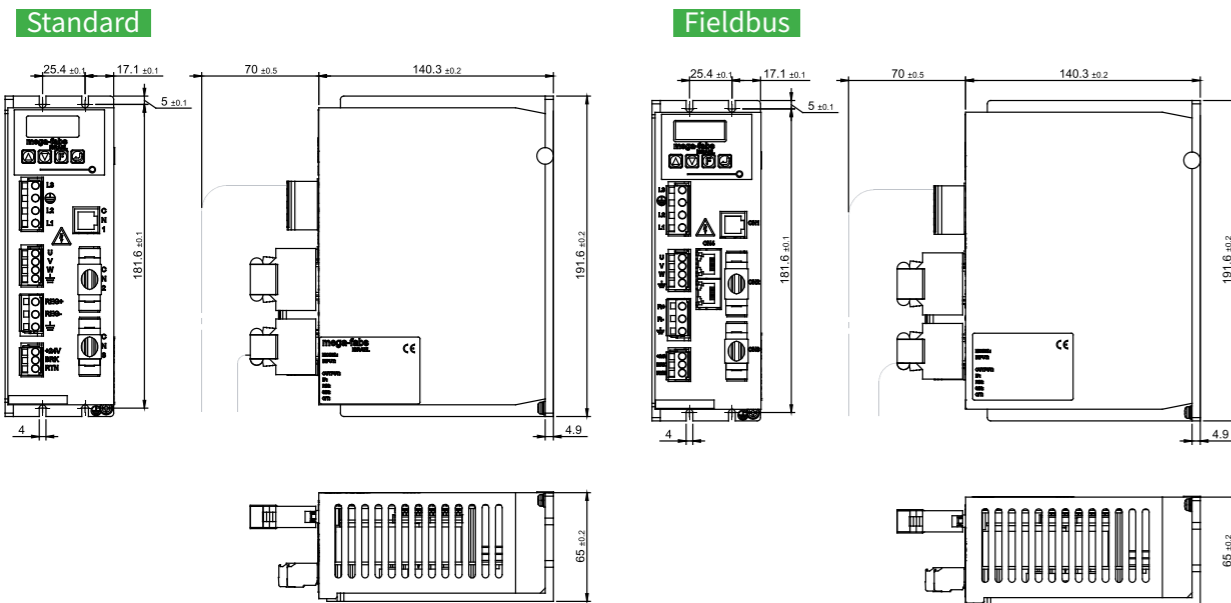
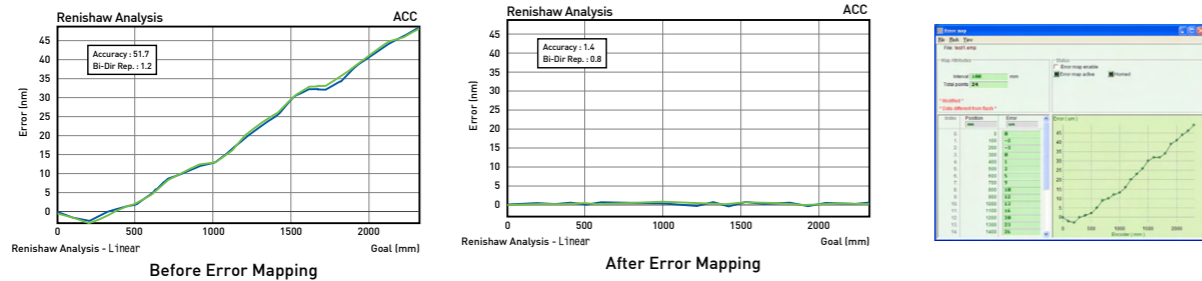

D1 Model Description

D1-36-S2-2-0-00

Rated Output

36: 36 A

Communication Interface

- S: Standard format RS232 (No communication interface)
- E: EtherCAT (CoE)
- F: EtherCAT (mega-ulink)

Encoder type

- 2: Analog
- 3: Digital
- 4: Resolver

Reserved Code

00: Standard

Heat Sink

- 0: Without heat sink
- 1: High profile (H1)

Input Voltage

2: Single/Three-Phase 220Vac

Note:
Model code can be generated via the sizing program on our website (<https://w3.hiwinmikro.tw/hiwincal.aspx>)

D1 Wiring Diagram

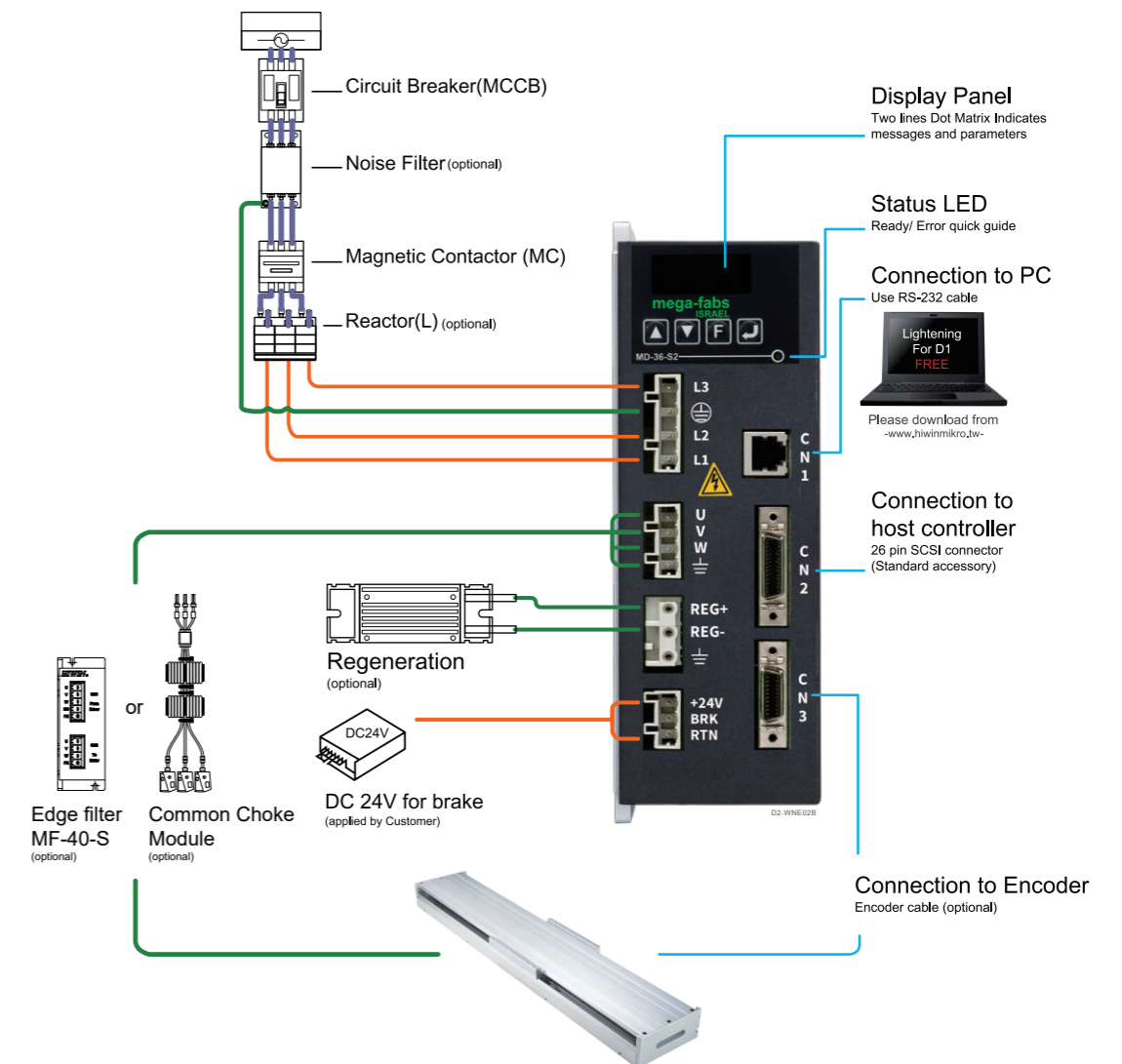

D1 Specification (User Manual" V3.0)

D1		D1-36	
Input Power	Voltage	100 - 240 Vac±10%	
	Frequency	47 to 63Hz	
	Phase	1Ø or 3Ø	
	Control Voltage	+24 Vdc 10%	
	Control Current	1 A minimum	
Output Power	Continuous Current	12 A_amp [8.5 A_rms] (Note: with external heat sink)	
	Instantaneous Current	36 A_amp [25.4 A_rms]	
	Allowable Continuous Time for Instantaneous Current	1 second maximum	
Drive Startup Time		1~2 seconds	
Drive Reset Time		3~4 seconds	
Main Circuit Control		IGBT PWN space vector control	
Control Motor Type		<ul style="list-style-type: none"> 13 bit AC servo motor Linear motor Torque motor 	
Status LED Indicator		Red: Error ; Green: Servo ready	
Position Mode	Input Port		[I9, I9M], [I10, I10M] differential inputs or I9, I10 single end inputs
	Pulse Command Mode		<ul style="list-style-type: none"> Pulse / Direction CW/ CCW AqB
	Maximum Input Pulse Frequency	Differential Signal	Pulse [2M pulses/ s max.] : Quad A/B [8M counts/s max.]
		Single End Signal	Pulse [500K pulses/ s max.] : Quad A/B [2M counts/s max.]
	Command Source		Pulse from controller
	Electronic Gear		Electronic gear ratio: pulses/ counts Pulses: 1~2147483647 ; Counts: 1~2147483647
Velocity Mode	Analog Input Command	Input Impedance	10 KΩ
		Voltage Range	± 10 Vdc
		Time Constant	2.2 us
		Resolution	12 bits
	Digital Input Command	PWM 100%	I9: PWM = 0% - 100% I10: Direction = 1/0
		PWM 50%	I9: PWM = 50% ± 50% I10: No function
		Frequency Range	36.5 KHz minimum, 100 KHz maximum
		Pulse Width Limit	220 ns minimum
Command Source		Voltage or PWM from controller	

Force/Torque Mode	Analog Input Command		Same as velocity mode.
	Digital Input Command		Same as velocity mode.
	Command Source		Voltage or PWN from controller
Encoder Type	Operating Voltage		+5 Vdc ± 5% @400 mA
	Digital	Input Signal	A,/ A, B, /B, Z, /Z, RS422 differential signal
		Bandwidth	5 MHz line frequency, x 4 frequency: 20 M counts/ s
	Analog	Input Amplitude	1 Vpp (sin/cos), differential signal
		Bandwidth	1 MHz maximum line (cycle) frequency
		Resolution	Maximum 65528 counts/ cycle
Resolver		Sin/ Cos, differential signal Reference 3 kHz, 6 Vpp, 100 mA	
Encoder Counting Range			-2147483648~2147483647 (32 bits) The motor commutation is normal and is not affected by encoder counting range
Buffered Encoder Output	Digital Encoder		<ul style="list-style-type: none"> Without being processed by the servo drive, A/B phase signals are directly sent to the controller. (Maximum 18 M counts/s, digital AqB output, differential signal output) Without being processed by the servo drive, Z phase signals are directly sent to the controller. (Differential signal) The delay time between the time the servo drive receives encoder signal from the encoder and the time the servo drive outputs signal from output pin is less than 100 nanosecond (ns).
	Analog Encoder		<ul style="list-style-type: none"> Maximum 18 M counts/s, digital AqB output, differential signal output The resolution is the grating period of analog encoder/4. (If grating period = 40 um, the resolution of buffered encoder output = 10 um/count) The delay time between the time the servo drive receives encoder signal from the encoder and the time the servo drive outputs signal from output pin is less than 100 nanosecond (ns).
Emulated Encoder Output			<ul style="list-style-type: none"> Maximum 18 M counts/s, digital AqB output, differential signal output The ratio of encoder input to emulated encoder output can be adjusted. The width of emulated index signal output can be adjusted. Linear motor: (1) Outputs one index (Z phase) signal per travel distance. Rotary motor: (1) Outputs one index (Z phase) signal per travel distance (2) Outputs one index (Z phase) signal per motor revolution <p>The maximum delay time between the time the servo drive receives encoder signal from the encoder and the time the servo drive outputs signal from output pin is 66.67 us.</p>
Digital Hall Signal			Digital single-ended signal with 120 degrees phase difference HA, HB, HC

Communication	Interface	Connect to PC via RS232
	Protocol	<ul style="list-style-type: none"> Full-duplex Baud rate: 9,600 ~ 115,200 bps Binary
Programmable I/O Interface	Digital Input	74HC14 Schmitt trigger input Inputs [I1~I6] [I11, I12] [I9, I10] 10 digital inputs are provided. Note: When I9 and I10 are set for digital inputs, they cannot be programmed as general inputs.
	Digital Output	0.3 Adc max, +40 Vdc max (Open drain) [O1~O3]
	Brake Output	Brake [O4], 1 Adc max.
PDL Editor	The Maximum Storage for Codes	32K Bytes
	Storage for Variables	800 Bytes
	Supported Variable Type	Float: 32 bits Integer: 16 bits and 32 bits (Array and pointer are supported.)
	Execution Cycle	66.67 us
	Multitasking	Four tasks can be run at the same time.
	Control Commands for Program Flow	Supports commands such as "if", "else", "while loop", "for loop", "goto", "till", etc.
	Operator	Includes arithmetic operators, logic operators and comparison operators.
	Task Synchronization	Supports Lock and Unlock commands to perform task synchronization.
	Length Limit for User-defined Name	<ul style="list-style-type: none"> Variable: 17 characters Label: 24 characters Proc: 24 characters
Regenerative Resistor	Resistor	External connection
	Voltage Threshold for Activation	+HV > 390 Vdc
	Voltage Threshold for Deactivation	+HV < 380 Vdc
	Hysteresis	10 V ± 0.5 Vdc
	DC Link Capacity	1880 uF
Protection Function		Short circuit, Overvoltage (> 400 Vdc ± 5%), Position error too big, Encoder error, Motor cable lost connection, Drive over temperature (IGBT > 80°C ± 3°C), Motor over temperature, Undervoltage (< 60 Vdc), I2T over current protection
Error Compensation	Motor Type	Linear motor
	Compensation Method	Creates error map to compensate encoder error by means of linear interpolation.
	Storage Point	Maximum 5,000 points
	Storage Location	Flash ROM, disk file
	Unit	um, count
	Enabling Method	Activated after internal homing or by an external input signal.
Frequency Suppression Range for Vibration Suppression Filter (VSF)		0.1 Hz~200 Hz
Environment	Operating Temperature	0~50°C (If temperature is above 55 °C, ventilation system is compulsory.)
	Storage Temperature	-20°C ~ 65°C
	Humidity	0 to 90%RH (non-condensing)

Environment	Altitude	Below 1,000m above sea level
	Vibration	1G (10 to 500 Hz)
	IP Rating	IP20
Cooling System		Natural cooling or external heat sinks
Weight		1,250 g (min.)
Dimensions		191.6 mm X 139.8 mm X 64.8 mm
Case		Complies with CE U.L. Spec 94 V-0 Flammability Rating

D2T-LM Drive

- High Speed Response.
- High Acceleration Response.
- Built-In Accuracy Improvement Function.
- Vibration Suppression Function.
- Electronic Gear Ratio and Encoder Emulator.
- PDL General Motion Language.



D2T-LM Model Description

D 2 T - 0 4 2 3 - S - B 5 - 0 L

Rated Output (Compatible Motor)

04: 400W
 (08S050~10S100~13S100~18S100~20C100~20C200)
 10: 1kW
 (08S100~10S200~13S200~18S200~
 18C100~18C200~20S300)
 (Not applicable if the above specifications are not listed)

Input Power

23: Single/Three-phase 220 Vac

Control Interface

S: Voltage command+pulse
 E: EtherCAT
 F: mega-ulink

Motor Code

OL: Linear motor series only

Encoder Interface

5: Digital TTL (AqB)

Frame Size

B : 400W
 C : 1kW

Note:
 Model code can be generated via the sizing program on our website
 (<https://w3.hiwinmikro.tw/hiwincal.aspx>).

D2T-LM Wiring Diagram

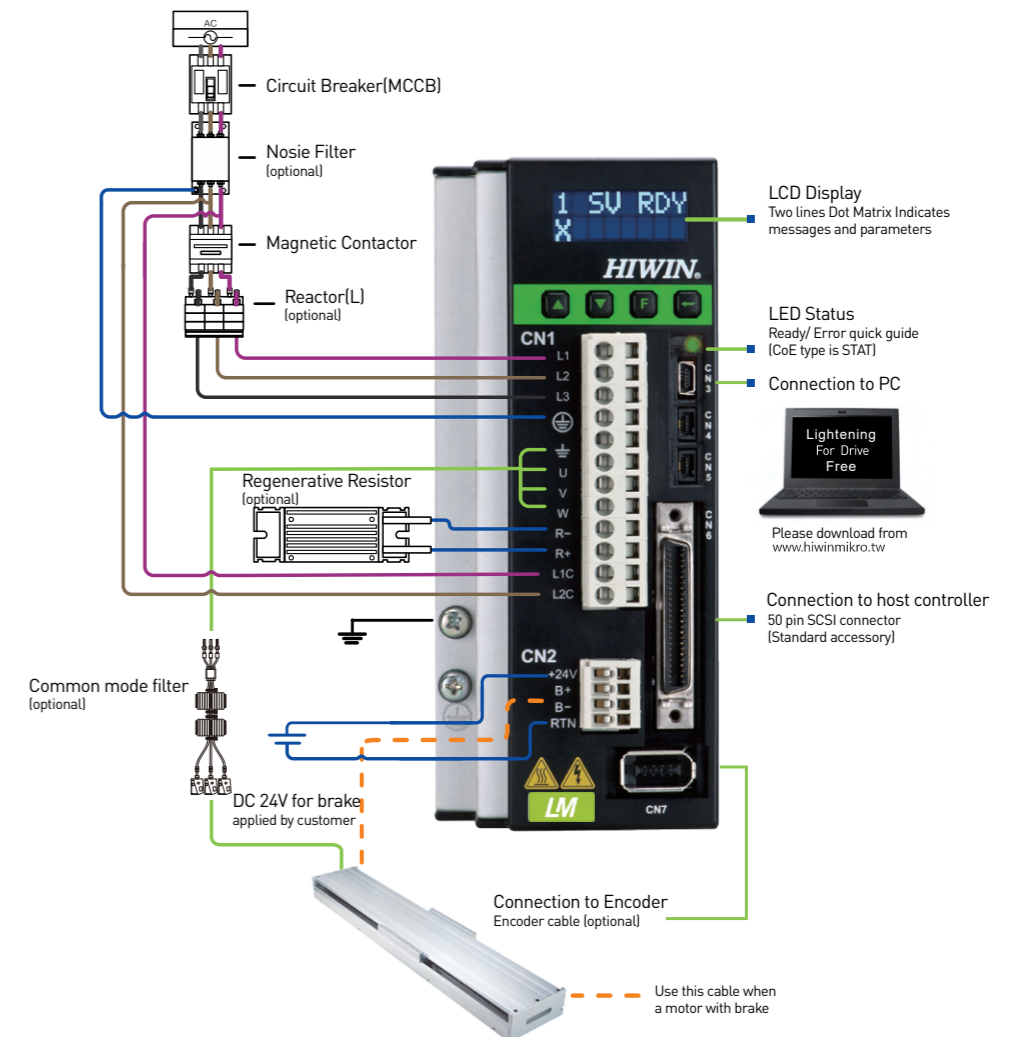

400W

Standard

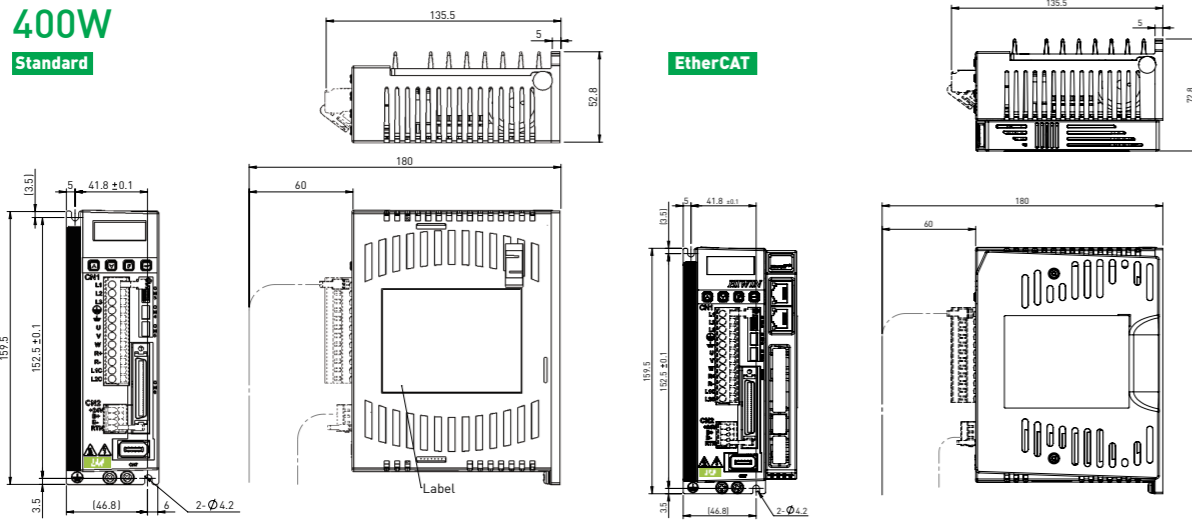

1KW

Standard

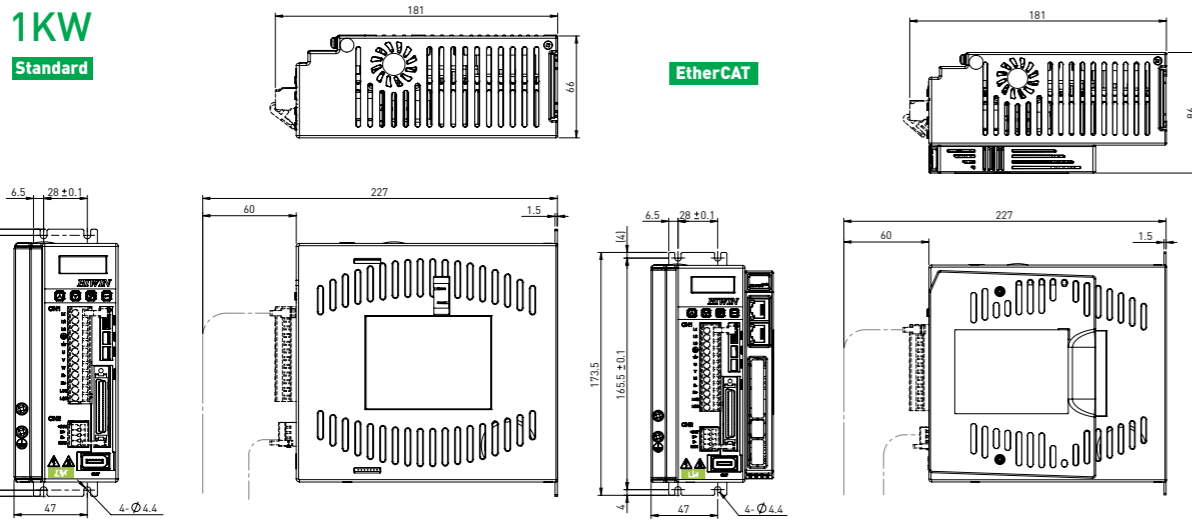

D2T-LM Specification (User Manual" V1.2)

Basic Specifications	Input Power 220V	Main Power	Frame B-C	Single/Three-phase, 200 - 240 Vac 50/60Hz
		Control Power	Frame B-C	Single phase, 200 - 240 Vac 50/60Hz
	Output Power	Power		Frame B: 400W; frame C: 1.0KW
		Continuous Current		Frame B: 2.5 Arms; frame C: 5.1 Arms
		Peak Current		Frame B: 7.5 Arms; frame C: 15.3 Arms
		Sustainable Duration of Peak Current		Maximum 1 second
	Environment	Temperature		Operation temperature: 0°C to 45°C (if over 55°C, a ventilation system is compulsory). Storage temperature: -20°C to 65°C
		Humidity		0 to 90%RH (Non-condensing)
		Altitude		Altitude 1,000 M or lower above sea level
		Vibration		1G (10 to 500Hz)
	Installation Pollution Level			II
	Control Method			IGBT PWM space vector control
	Encoder Input	Feedback Resolution		Digital TTL
		Frequency		5M pulse/sec (Before Quadrature);20M count/sec (After Quadrature).
		Other		The linear encoder should be the digital AqB encoder.
	Parallel I/O Connector	Control Signal	Input	Linear encoder should be digital AqB encoder.
			Output	5 (general purpose)
		Analog Signal	Input	1 (12-bit A/D)
			Output	2 (analog monitor)
		Pulse Signal	Input	2 (low-speed channel,high-speed channel)
Output			4 (line driver:3 outputs; open collector:1 output)	
Brake Connector	Control Signal	Output	Connection with brake. (1 Adc max). Also, it is programmable for general-purpose output.	
Dynamic Brake			No built-in dynamic brake. External relay and brake resistor are needed.	
Communication Function		USB	Used to connect with PC, 115,200 bps	
Front Panel			LCD status display: dot matrix 8*2 characters with 4 buttons; LED status indicator lights (green, red)	
Control Mode			Switchable control modes (1) Position control; (2) Velocity control; (3) Torque control ; (4) Position/velocity control; (5) Position/torque control ; (6) Velocity/torque control;	
Function Specifications	Position Control	Control Input	(1) Command pulse inhibit; (2) Axis enable; (3) Switch between primary and secondary CG; (4) Electronic gear selection; (5) Left limit switch; (6) Switch between primary and secondary mode; (7) Clear error; (8) Right limit switch, etc.	
		Control Output	(1) Servo ready; (2) Errors; (3) In-position; (4) Zero speed detected, etc.	
		Pulse Input	Maximum Input Pulse Frequency	Photo-coupler interface (single-ended input): 250 Kpps; Line driver interface (differential input): 4 Mpps (16M count/s with AqB).
			Signal Format of Input Pulse	(1) Pulse/direction (Pulse/Dir); (2) Pulse up/pulse down (CW/CCW); (3) Quadrature (AqB).
			Electronic Gear (Division/ Multiplication of Command Pulse)	Gear ratio: pulses/counts Pulses: 1 - 2,147,483,647; counts: 1 - 2,147,483,647.
			Smoothing Filter	Smooth factor: 1 - 500
		VSF	VSF can remove the vibration frequency that occurs during the movement. It can also reduce the vibration caused by the system's structure to enhance productivity.	

Velocity Control	Control Input		(1) Zero speed clamp; (2) Axis enable; (3) Switch between primary and secondary CG (4) Left limit switch (5) Switch between primary and secondary mode (6) Clear error (7) Right limit switch, etc.
	Control Output		(1) Servo ready; (2) Errors; (3) In-velocity; (4) Zero speed detection, etc.
	PWM Input	Velocity Command Input	Velocity commands can be provided by the duty cycle of PWM input. Parameters are used to set the scale and command direction.
	Analog Input	Velocity Command Input	Velocity command can be provided by the analog voltage. Parameters are used to set the scale and command direction. (+/-10Vdc 12-bits resolution)
Zero Speed Clamp			The input of zero speed clamp is possible.
Torque Control	Control Input		(1) Axis enable;(2) Switch between primary and secondary CG; (3) Left limit switch; (4) Switch between primary and secondary mode; (5) Clear error; (6) Right limit switch, etc.
	Control Output		(1) Servo ready; (2) Errors; (3) In-velocity; (4) Zero speed detected, etc.
	PWM Input	Torque Command Input	Torque commands can be provided by the duty cycle of PWM input. Parameters are used to set the scale and command direction.
	Analog Input	Torque Command Input	Torque commands can be provided by the analog voltage. Parameters are used to set the scale and command direction. (+/-10Vdc 12-bits resolution)
Speed Limit Function			The parameter for speed limit can be set.
Emulated Encoder Feedback Output			Can be arbitrarily set (The maximum frequency of frame B - C models is 18M count/s)
Common	Protection Function		(1) Motor short detected; (2) Over voltage detected (> 390 Vdc ± 5%); (3) Position error too big;(4) Encoder error; (5) Soft-thermal threshold reached; (6) Motor maybe disconnected; (7) Amplifier over temperature (IGBT > 80°C ± 3°C); (8) Under voltage detected; (9) 5V for encoder card fail; (10) Phase initialization error (11) Serial encoder communication error
	Error Log		Errors and warnings are saved in the non-volatile memory.
	Process Design Language (PDL)		Maximum code capacity: 32 KBytes
			Variable storage capacity: 800 Bytes
			Supported variable type: (1) Float type: 32 bits; (2) Integer type: 16 and 32 bits; (3) Array and pointer supported.
			Execution cycle: 66.67 us
			4 tasks can be executed simultaneously.
			Support if, else, while loop, for loop, goto, till, and other commands to control program flow.
	Support arithmetic operators, logical operators, and comparison operators.		
	Support lock and unlock commands to control the synchronization of multi-tasks.		
Maximum length of user-defined name: (1) variable: 17 characters (2) label: 24 characters (3) proc: 24 characters			
Error Mapping		Method: Establish error map to compensate the encoder error by using the linear interpolation. Storage point: Maximum 5,000 points. Storage location: Flash ROM; disc file. Unit: count. Enable method: activated after internal homing or by an external input signal.	
Regeneration	Resistor		Need external connection, and have no built-in regenerative resistor.
	Voltage Threshold for Activation		+HV > 370Vdc
	Voltage Threshold for Deactivation		+HV < 360Vdc
	DC Link Capacity		frame B: 820 uF; frame C: 1,410 uF

Cable and Pin Assignment

Power Cable Pin Assignment

Iron core Motor		Ironless Motor	
Signal	Color	Signal	Color
V	Black-2	V	White
U	Black-1	U	Brown
W	Black-3	W	Grey
GND	Green/Yellow	GND	Shield
T+	Black-5	T+	Yellow
T-	Black-6	T-	Green
	Shield		Shield

Limit Switch Pin Diagram



Limit Switch			
Work	Function	Signal	Color
+Limit	Power	12V~24V	Brown
		0V	Blue
	Output	NPN/PNP	Black
-Limit	Power	12V~24V	Brown
		0V	Blue
	Output	NPN/PNP	Black
Near home sensor	Power	12V~24V	Brown
		0V	Blue
	Output	NPN/PNP	Black

Encoder Cable Pin Assignment (Stage wiring side)

Digital Magnetic Encoder			
Function	Signal	Color	D-Sub Male-15P
Power	5V	Brown	7
	0V	White	2
Incremental signals	A+	Green	14
	A-	Yellow	6
	B+	Blue	13
	B-	Red	5
Reference mark	Z+	Violet	12
	Z-	Grey	4
Shield			case

Digital Optical Encoder			
Function	Signal	Color	D-Sub Male-15P
Power	5V	Brown	7,8
	0V	White	2,9
Incremental signals	A+	Red	14
	A-	Blue	6
	B+	Yellow	13
	B-	Green	5
Reference mark	Z+	Violet	12
	Z-	Grey	4
Shield	Inner	Inner Shield	15
	Outer	Outer Shield	case

Analog Magnetic / Hall Encoder			
Function	Signal	Color	D-Sub Male-15P
Power	5V	Brown	4
	0V	White	12
Incremental signals	SIN+	Green	9
	SIN-	Yellow	1
	COS+	Blue	10
	COS-	Red	2
Reference mark	REF+	Violet	3
	REF-	Grey	11
Shield			case

Analog Optical Encoder			
Function	Signal	Color	D-Sub Male-15P
Power	5V	Brown	4
		Brown(link)	5
	0V	White	12
		White(link)	13
Incremental signals	V1+	Red	9
	V1-	Blue	1
	V2+	Yellow	10
	V2-	Green	2
Reference mark	V0+	Pink	3
	V0-	Grey	11
Shield	Inner	-	15
	Outer	-	case

Absolute Optical Encoder			
Function	Signal	Color	D-Sub Male-9P
Power	5V	Brown	4,5
	0V	White Green	8,9
Serial communication	MA+	Violet	2
	MA-	Yellow	3
	SLO+	Grey	6
	SLO-	Pink	7
Shield	-	-	case

Encoder Extension Cable

Pin assignment			
Housing (F)	Color	Signal	SCSI 20P(M)
1	Brown	T+	14
2	Blue	T-	15
D-Sub 15P (F)	Color	Signal	
7	Brown	5V	3
	Green		
2	White	0V	2
	Yellow		
14	Gray	A+	4
6	Pink	A-	5
13	Blue	B+	6
5	Red	B-	7
12	Black	Z+	8
4	Violet	Z-	9
3	White/Green	Encoder Alarm	18
15	Inner Shield		20
Case	Outer Shield		1

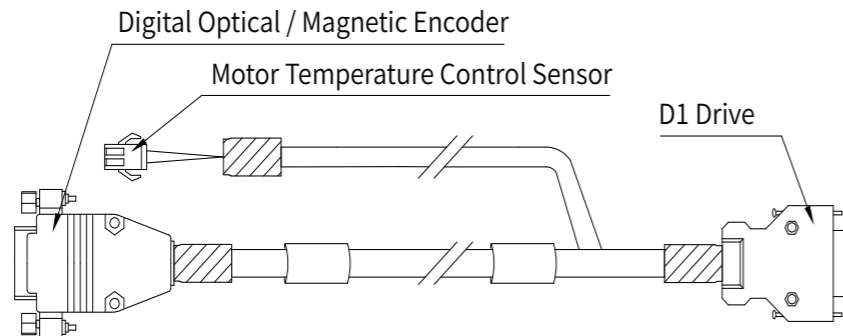

Corresponding Encoder (E,G,K) Extension Cable Number			
Drive	Cable Length		
	0.4M	2M	4M
D1	HE00VJQ81100	HE00VJQ84200	HE00VJQ84400

Pin assignment			
D-Sub 15P (F)	Color	Signal	R-36210 (F)
7	Brown	5V	1
8	Pink		
2	White	0V	2
9	Black		
14	Green	A+	5
6	Yellow	A-	6
13	Blue	B+	7
5	Red	B-	8
12	Violet	Z+	9
4	Gray	Z-	10
15	Inner Shield		2
Case	Outer Shield		Case

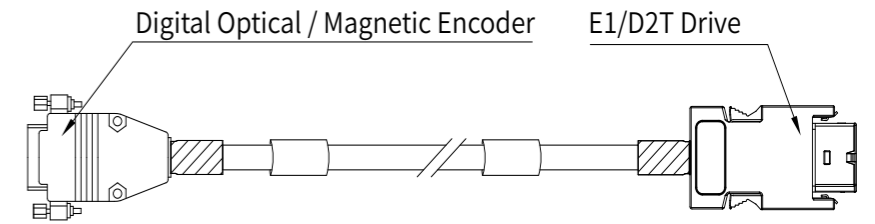

Corresponding Encoder (E,G,K) Extension Cable Number			
Drive	Cable Length		
	0.4M	2M	4M
D2T/E1	HE00VJQ82100	HE00EJ6DF200	HE00EJ6DF400

Pin assignment			
Housing (F)	Color	Signal	SCSI 20P(M)
1	Brown	T+	14
2	Blue	T-	15
D-Sub 15P (F)	Color	Signal	
7	Brown	5V	3
	Green		
2	White	0V	2
	Yellow		
14	Gray	A+	4
6	Pink	A-	5
13	Blue	B+	6
5	Red	B-	7
12	Black	Z+	8
4	Violet	Z-	9
3	White/Green	Encoder Alarm	18
15	Inner Shield		20
Case	Outer Shield		1
D-Sub 9P(F)	Color	Signal	
1	Brown	5V	3
2	White	Hall A	11
3	Grey	Hall B	12
4	Yellow	Hall C	13
5	Green	0V	10
Case	Shield		1

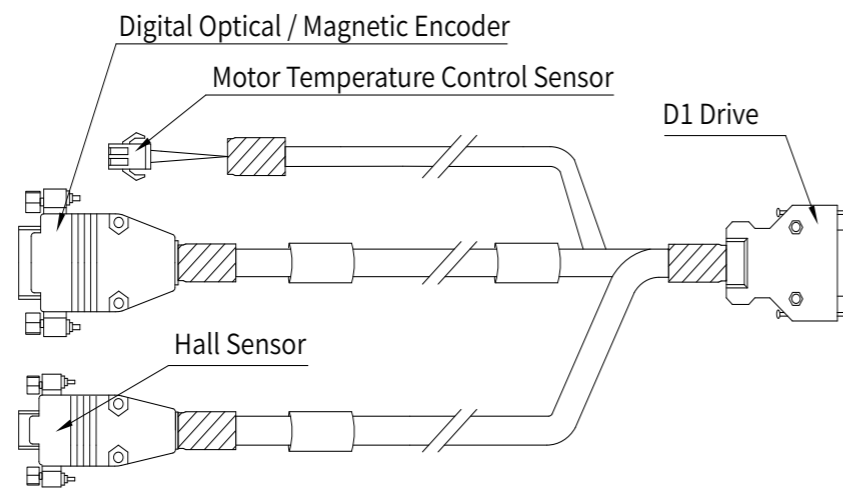

Corresponding Encoder (E,G,K) Extension Cable Number			
Drive	Cable Length		
	0.4M	2M	4M
D1	HE00VJQ81000	HE00VJQ87200	HE00VJQ87400

Pin assignment			
D-Sub 15P (F)	Color	Signal	(HD)VGA 26Pin(M)
7	White	5V	4
8	Green		
2	Brown	0V	13
9	Yellow		
14	Grey	V1+	19
6	Pink	V1-	20
13	Blue	V2+	21
5	Red	V2-	22
12	Black	V0+	3
4	Violet	V0-	12
11	White/Green	E+	7
3	Brown/Green	E-	17
15	Inner Shield		15
Case	Outer Shield		Case
D-Sub 9P(F)	Color	Signal	
1	Brown	5V	5
2	White	Hall U	8
3	Grey	Hall V	18
4	Yellow	Hall W	9
5	Green	0V	14
Case	Shield		Case

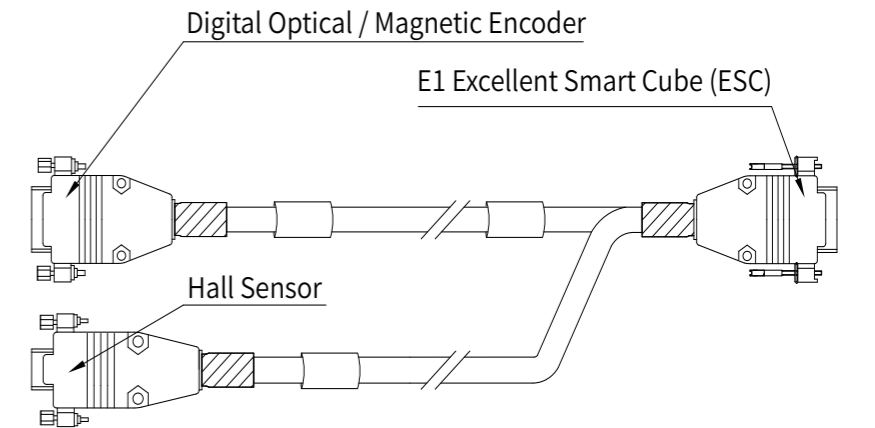

Corresponding Encoder (E,G,K) Extension Cable Number			
Drive	Cable Length		
	0.4M	2M	4M
E1	HE00EKTDAQ00	HE00EKTDA200	HE00EKTDA400

Pin assignment

Housing (F)	Color	Signal	SCSI 20P(M)
1	Brown	T+	14
2	Blue	T-	15
D-Sub 15P (F)		Color	Signal
4	Brown	5V	3
12	White	0V	2
9	Green	V1+	16
1	Yellow	V1-	17
10	Blue	V2+	18
2	Red	V2-	19
3	Violet	V0+	8
11	Grey	V0-	9
15	Inner Shield		20
Case	Outer Shield		1,Case

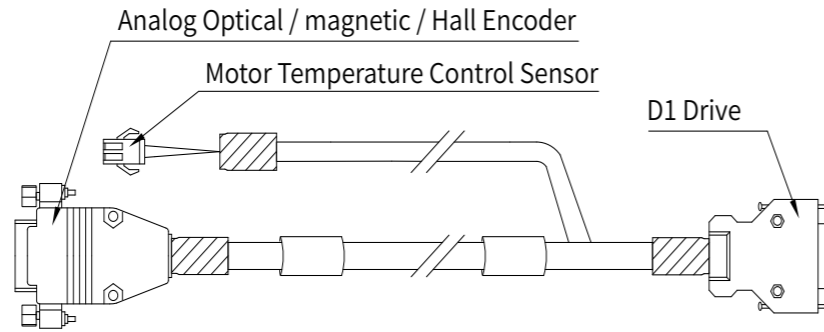

Corresponding Encoder (A,H) Extension Cable Number

Drive	Cable Length		
	0.4M	2M	4M
D1	HE00VJQ86300	HE00VJQ85600	HE00VJQ85700

Pin assignment

D-Sub 15P (F)	Color	Signal	(HD)VGA 26Pin(M)
4	White	5V	4
5	Green		5
12	Brown	0V	13
13	Yellow		14
9	Grey	V1+	1
1	Pink	V1-	10
10	Blue	V2+	2
2	Red	V2-	11
3	Black	V0+	3
11	Violet	V0-	12
15	Inner Shield		15
Case	Outer Shield		Case

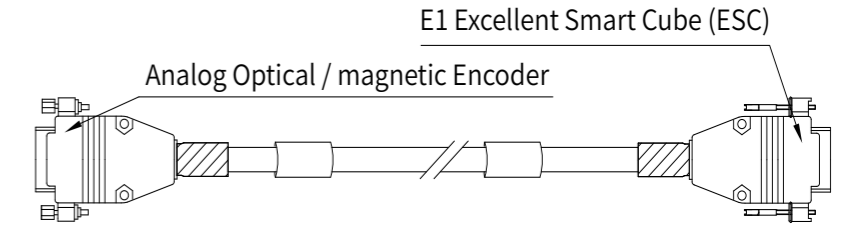

Corresponding Encoder (A) Extension Cable Number

Drive	Cable Length		
	0.4M	2M	4M
E1	HE00EK1DAQ00	HE00EK1DA200	HE00EK1DA400

Pin assignment

Housing (F)	Color	Signal	SCSI 20P(M)
1	Brown	T+	14
2	Blue	T-	15
D-Sub 15P (F)		Color	Signal
4	Brown	5V	3
12	White	0V	2
9	Green	V1+	16
1	Yellow	V1-	17
10	Blue	V2+	18
2	Red	V2-	19
3	Violet	V0+	8
11	Grey	V0-	9
15	Inner Shield		20
Case	Outer Shield		1,Case
D-Sub 9P(F)		Color	Signal
1	Brown	5V	3
2	White	Hall A	11
3	Grey	Hall B	12
4	Yellow	Hall C	13
5	Green	0V	10
Case	Shield		1

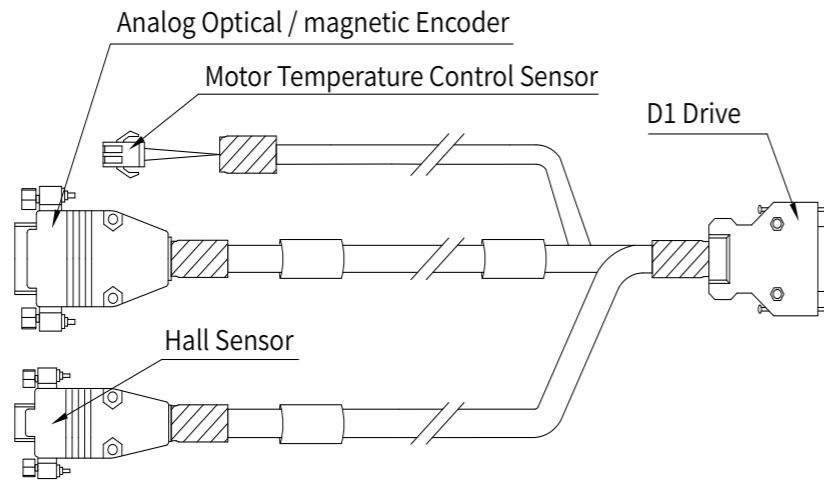

Corresponding Encoder (A) Extension Cable Number

Drive	Cable Length		
	0.4M	2M	4M
D1	HE00VJQ86400	HE00VJQ85800	HE00VJQ85900

Pin assignment

D-Sub 15P (F)	Color	Signal	(HD)VGA 26Pin(M)
4	White	5V	4
5	Green		5
12	Brown	0V	13
13	Yellow		14
9	Grey	V1+	1
1	Pink	V1-	10
10	Blue	V2+	2
2	Red	V2-	11
3	Black	V0+	3
11	Violet	V0-	12
15	Inner Shield		15
Case	Outer Shield		Case
D-Sub 9P(F)		Color	Signal
1	Brown	5V	5
2	White	Hall U	8
3	Grey	Hall V	18
4	Yellow	Hall W	9
5	Green	0V	14
Case	Shield		Case

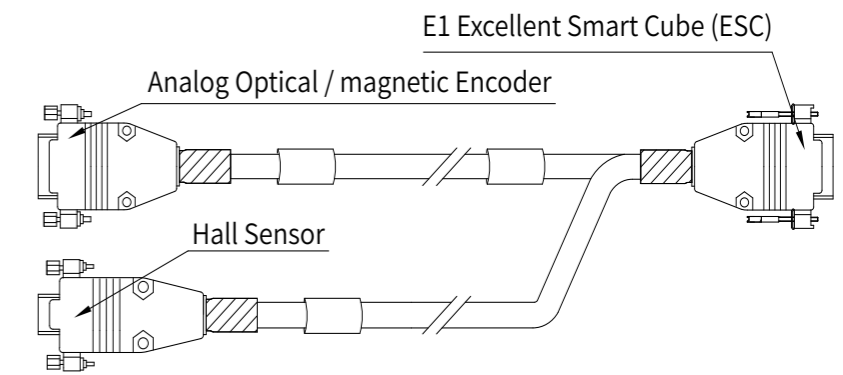

Corresponding Encoder (A) Extension Cable Number

Drive	Cable Length		
	0.4M	2M	4M
E1	HE00EJVDAQ00	HE00EJVDA200	HE00EJVDA400

Pin assignment

D-Sub 9P (F)	Color	Signal	(HD)VGA 26Pin(M)
4	Brown	5V	4
5	Brown		5
8	White	0V	13
9	Green		14
6	Gray	DATA+	23
7	Pink	DATA-	24
2	Violet	CLK+	7
3	Blue	CLK-	17
Case	Outer Shield		Case

Absolute Optical (Biss-C) E1 Excellent Smart Cube (ESC) Encoder

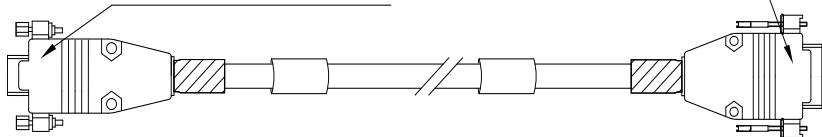

Corresponding Encoder (P) Extension Cable Number

Drive	Cable Length		
	0.4M	2M	4M
E1	HE00EKSDAQ00	HE00EKSDA200	HE00EKSDA400

Pin assignment

D-Sub 15P (F)	Color	Signal	(HD)VGA 26Pin(M)
7	White	5V	4
8	Green		
2	Brown	0V	13
9	Yellow		
14	Grey	V1+	19
6	Pink	V1-	20
13	Blue	V2+	21
5	Red	V2-	22
12	Black	V0+	3
4	Violet	V0-	12
11	White/Green	E+	7
3	Brown/Green	E-	17
15	Inner Shield		15
Case	Outer Shield		Case

Digital Optical / Magnetic Encoder

E1 Excellent Smart Cube (ESC)

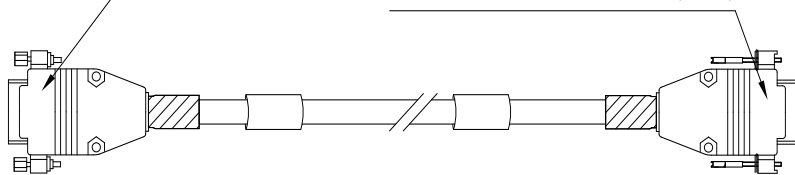

Corresponding Encoder (E,G,K) Extension Cable Number

Drive	Cable Length		
	0.4M	2M	4M
E1	HE00EKTDBQ00	HE00EKTDB200	HE00EKTDB400

Single-Axis Linear Motor Stage Technical Information

Publication Date : March 2019, first edition

Print Date : August 2021, 2nd edition

1. HIWIN is the registered trademark of HIWIN Group. For your protection, avoid buying counterfeit products from unknown sources.
 2. Actual products may differ from specifications and photos provided in this catalog. These differences may be the result of various factors including product improvements.
 3. HIWIN will not sell or export products or processes restricted under the "Foreign Trade Act" or related regulations. Export of restricted products should be approved by proper authorities in accordance with relevant laws and shall not be used to manufacture or develop nuclear, biochemical, missiles or other weapons.
-



Global Sales And Customer Service Site

HIWIN GmbH

OFFENBURG, GERMANY
www.hiwin.de
www.hiwin.eu
info@hiwin.de

HIWIN JAPAN

KOBE · TOKYO · NAGOYA · NAGANO ·
TOHOKU · SHIZUOKA · HOKURIKU ·
HIROSHIMA · FUKUOKA · KUMAMOTO,
JAPAN
www.hiwin.co.jp
info@hiwin.co.jp

HIWIN USA

CHICAGO, U.S.A.
www.hiwin.us
info@hiwin.com

HIWIN Srl

BRUGHERIO, ITALY
www.hiwin.it
info@hiwin.it

HIWIN Schweiz GmbH

JONA, SWITZERLAND
www.hiwin.ch
info@hiwin.ch

HIWIN s.r.o.

BRNO, CZECH REPUBLIC
www.hiwin.cz
info@hiwin.cz

HIWIN FRANCE

STRASBOURG, FRANCE
www.hiwin.fr
info@hiwin.de

HIWIN SINGAPORE

SINGAPORE
www.hiwin.sg
info@hiwin.sg

HIWIN KOREA

SUWON · CHANGWON, KOREA
www.hiwin.kr
info@hiwin.kr

HIWIN CHINA

SUZHOU, CHINA
www.hiwin.cn
info@hiwin.cn

Mega-Fabs Motion Systems, Ltd.

HAIFA, ISRAEL
www.mega-fabs.com
info@mega-fabs.com

HIWIN MIKROSYSTEM CORP.

No.6, Jingke Central Rd.,
Taichung Precision Machinery Park,
Taichung 40852, Taiwan
Tel: +886-4-23550110
Fax: +886-4-23550123
www.hiwinmikro.tw
business@hiwinmikro.tw