

Global Sales & Service Network

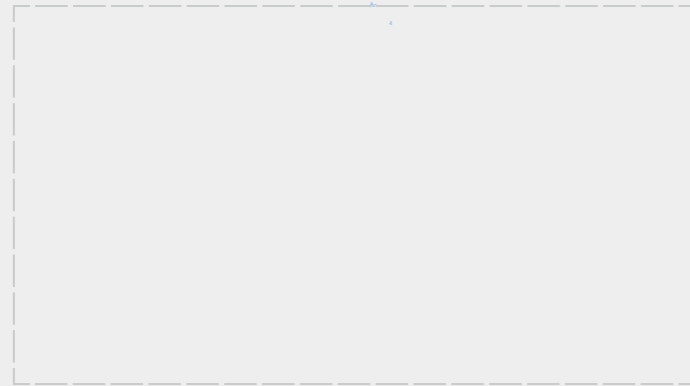
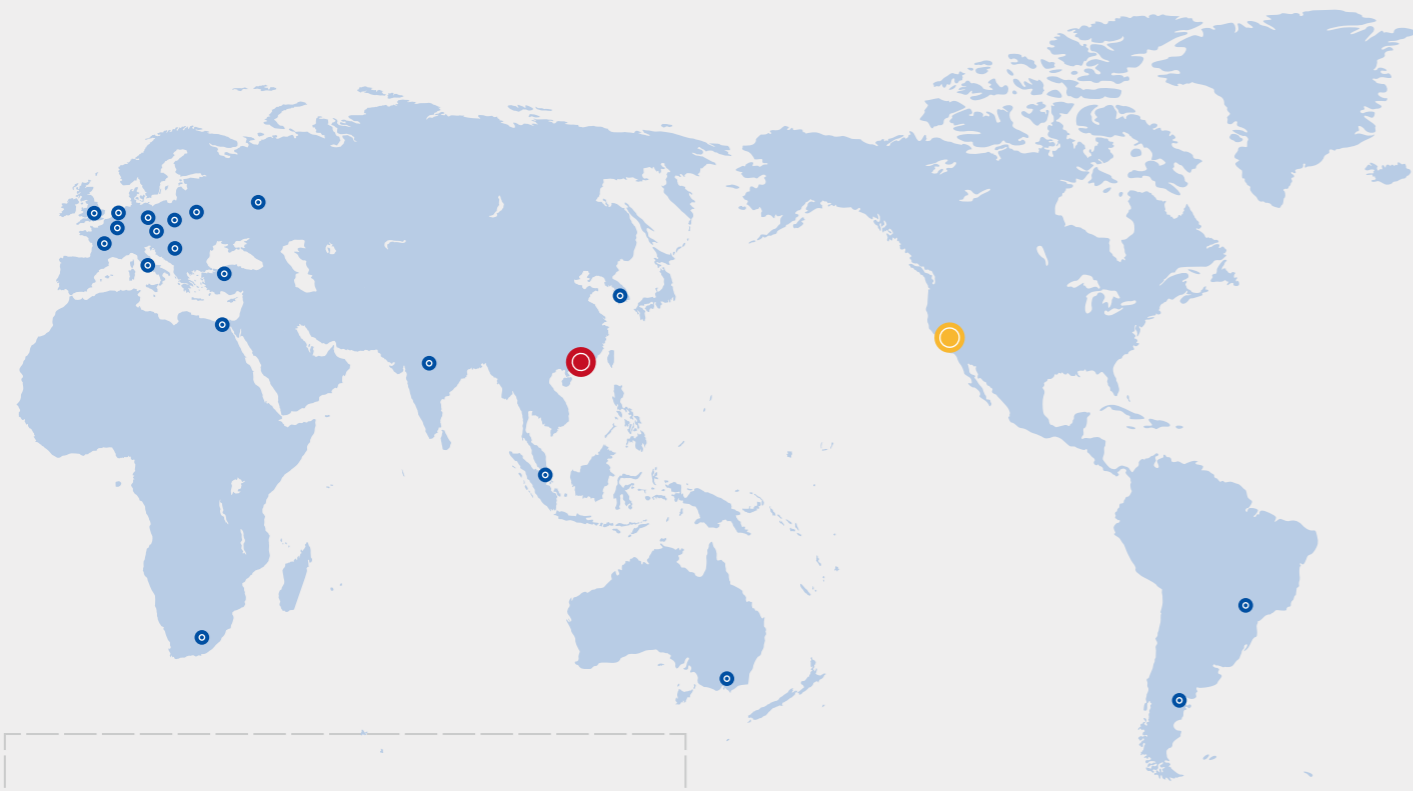

Headquarters Leadshine Technology Co., Ltd.

Address: 15-20/F, Block B, Nanshan I Valley, No.3157,
Shahe West Road, Nanshan District, Shenzhen,
Guangdong, China
Tel: +86-755-26411692
Fax: +86-755-2640 2718
Website: www.leadshine.com
Emails: sales@leadshine.com(Sales)
tech@leadshine.com(Technical Support)

North America Office Leadshine America, Inc.

Address: 26050 Towne Centre Dr.
Foothill Ranch, CA 92610,
USA
Tel: 1-949-608-7270
Fax: 1-949-638-7298
Website: www.Leadshineusa.com
Email: sales@leadshineusa.com(Sales)
support@leadshineusa.com(Technical Support)



SERVO PRODUCTS

- Overview
- AC Servo Systems
- DC Servo Systems
- Integrated Servo Motors
- Power Supplies
- Accessories



Company Profile

Founded in 1997 by Warren Li, a MIT PhD graduate.

Leadshine Technology Co., Ltd. is a leading technology company dedicated to designing, manufacturing, marketing, and selling affordable high performance motion control products based on the latest control technologies.

Our products include stepper and closed loop stepper products & AC servo products, integrated stepper & servo motors, motion controllers, motion PLCs, I/O module etc.

Today, Leadshine is a publicly listed company(stock code002979)with over 1,000 employees and 4 manufacturing facilities in China. We are the largest stepper product manufactures in China, and serve 10,000+ OEM clients from 60+ countries and in tens of industries.



Leadshine Shenzhen Headquarter



Shanghai Intelligent Industry Park



Production base in Shenzhen

R&D

Led by Dr. Li, a PhD majored in robotics & servo controls from MIT, Leadshine has one of the strongest R&D teams in the motion control industry.

The team consists of more than 100 R&D engineers and all of them are highly educated with most of them carry PhD & Master degrees in controls, electrical & electronics engineering, mechanical engineering, mechatronics, computer engineering, and computer science.

Their strong background and experience allow Leadshine capable of designing superior quality products based the latest technology in the most efficient way.

Product Quality

Leadshine operates manufacturing facilities which are superiorly equipped, professionally staffed, and ISO-9001 certified.

That allows Leadshine to provide highly reliable quality motion control products OEM clients in the shortest time.

Leadshine's products have proven records of being successfully adopted in thousands of applications such as CNC routers, mills, plasmas, lathes, laser cutters/engravers/markers,

inkjet printers, plotters, electronics equipments, medical equipments, semiconductor assembly & inspection machines, electronics machines, packaging equipments, textile machines,

robotics, pick-and-place devices, etc. In most cases, Leadshine's standard "off-the-shelf" products are able to satisfy the motion control needs for most applications.

For many OEM applications with special requirements, Leadshine also offers customized products with optimized performance.

Support and Service

Leadshine believes the key to be a successful motion product supplier is the commitment to fully understanding our customer's applications and working closely with our OEM clients.

In many cases, Leadshine engineers can participate in the whole process of client product development, including initial application evaluation, product selection, design help & suggestion.

Our expertise and experience allow us to help OEM clients to produce competitive high quality machines in their industries.

Contents

Overview

Company Profile	01
Typical Industry Applications	04
Product Overview	05
Product Quick Selection	07

AC Servo Systems

EL6 Series AC Servo Drives	12
EL7 Series AC Servo Drives	20
EL7 - ECF Series 220/380VAC Models 	20
EL7 - PNF Series (Coming Soon)	29
EL8 Series AC Servo Drives	30
EL8 - ECF Series 	30
EL8 - RSF Series 	35
AC Servo Motors	42
Accessories	55

DC Servo Systems

ELD2 Series DC Servo Drives	59
2ELD2 Series DC Servo Drives (Dual-axis) 	63
DC Servo Motors	66

Integrated Servo Motors

iSV2 Series Integrated Servo Motors	69
iSV Series Integrated Servo Motors	75

Power Supplies

Power Supplies	77
----------------	----

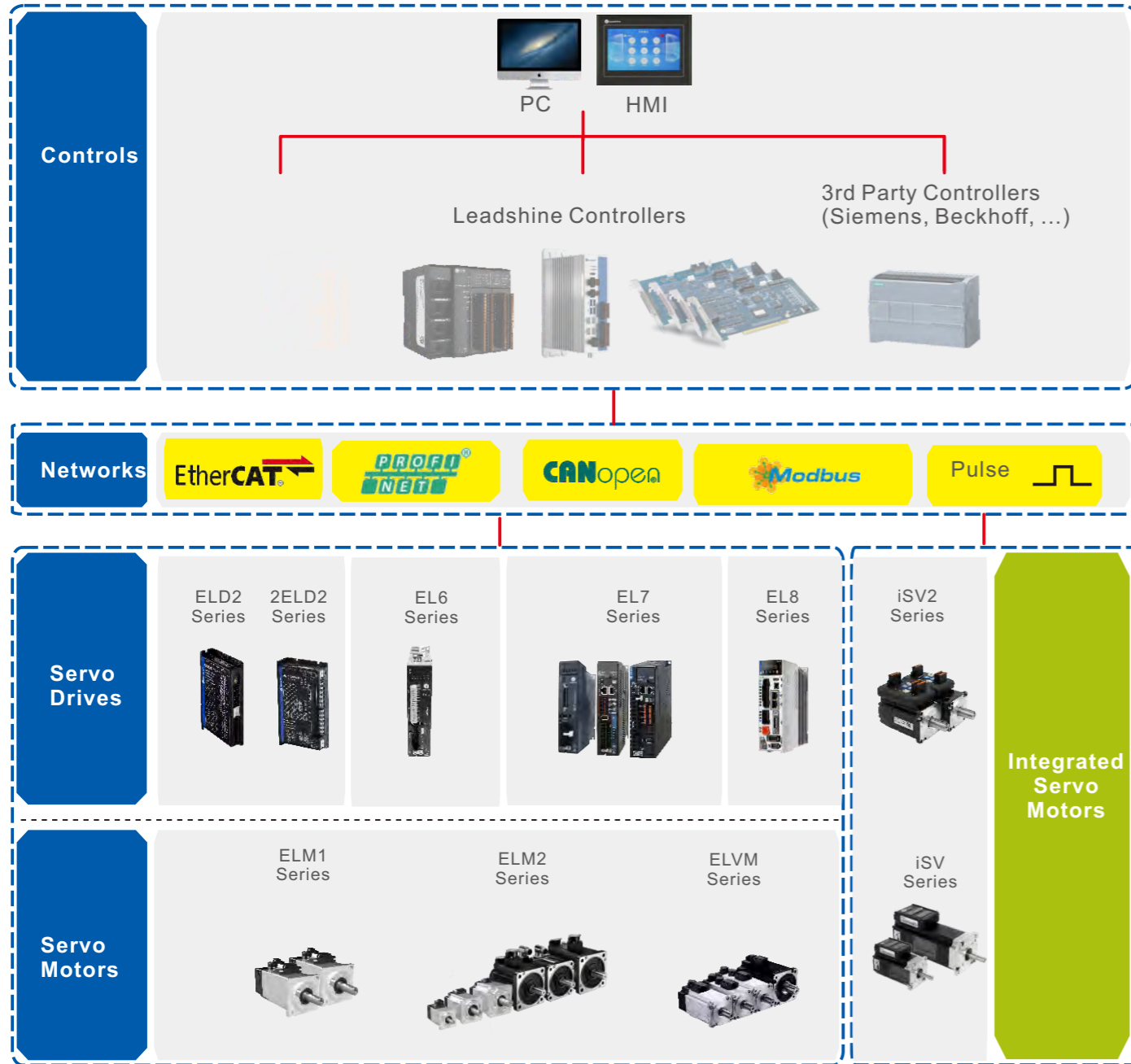

Why Leadshine



Over 30,000,000 installed stepper & servo axes worldwide since 1997

Typical Industry Applications

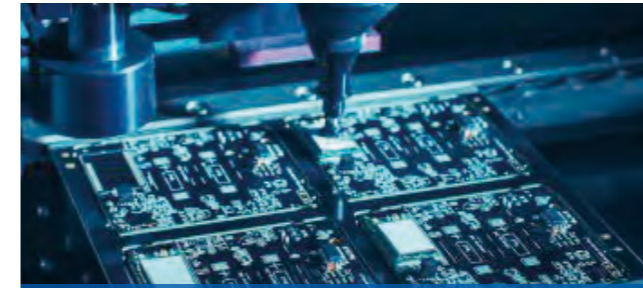

Electronic manufacturing equipment

- Dispensing machine
- Screw locking machine
- SMT
- Wire stripping machine
- Lithium battery equipment



Laser machine industry

- Laser marking machine
- Laser cutting machine
- Jade carving machine
- Wood carving machine



Special machine tool industry

- CNC machine
- Die stamping machine



AGV logistics industry

- Warehouse robot
- Sorting robot
- Cross belt sorter
- Inclined guide wheel sorter
- Multi-layer shuttle



Packaging

- Filling machine
- Pillow packaging machine
- Labeling machine
- Vertical packaging machine



Industrial robots

- Multi-joint industrial robot
- SCARA robot
- Injection molding robot
- Stamping robot

Product Overview

EL6 AC Servo Systems

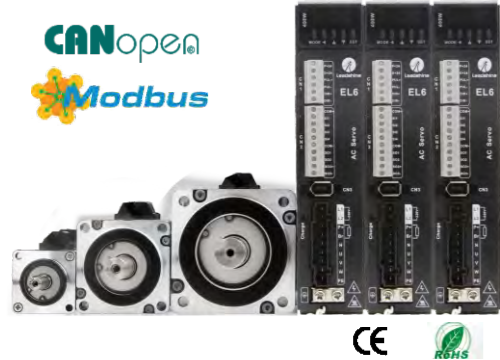

Power Rating: 50W - 1.0kW
Input Voltage: 220VAC 1ph input
Motor: 40-130mm frame size with 17bit/23bit encoder
Features:

- Automatic motor identification
- Notch filter, damping filter

Command source:

- Pulse+Direction / Modbus RTU / CANopen
- 16 PR paths

Inputs and Outputs:

- Max pulse input: 500 kHz
- 4 programmable digital inputs
- 3 programmable digital outputs
- A/B/Z-phase differential output, Z-phase OC output

- Position Mode
- Velocity Mode
- Torque Mode

EL7- RS AC Servo Systems-220VAC Models



Power Rating: 400W - 2.0kW
Input Voltage: 220VAC 1ph input
Motor: Frame size 40/60/80/130mm with 23 bit encoder
Command source:

- 16PR paths
- Pulse+Direction / Analog input / Modbus RTU

Inputs and Outputs:

- Max pulse input: 4MHz
- 8 programmable digital inputs
- 5 programmable digital outputs
- 2 analog inputs: -10V to +10V
- 1 analog output: -10V to +10V
- A/B/Z-phase differential output, A/B/Z-phase OC output

- Position Mode
- Velocity Mode
- Torque Mode

EL7-EC/PNF AC Servo Systems – 220/380VAC Models



Power Rating:
 EL7 - EC/PNF – 400W-2.0kW
 EL7- ECFT – 750W-7.5kW
Input Voltage: 220VAC 1ph, 380VAC 3ph
Motor: 220VAC models with frame size 40/60/80/130mm
 380VAC models with frame size 130/180mm
Features:

- Comes with STO SIL3

Command source:

- EtherCAT / Profinet

Inputs and Outputs:

- 4 programmable digital inputs
- 3 programmable digital outputs
- A/B/Z-phase differential output, Z-phase OC output

- Position Mode
- Velocity Mode
- Torque Mode

EL8 AC Servo Systems-220VAC Models



Power Rating: 400W - 2.0kW
Input Voltage: 220VAC 1ph/3ph input
Motor: 40/60/80/130frame size with 23bit encoder
Features:

- Frequency response up to 3.5kHz
- Easy 1-click tuning
- 42 points position comparison
- Full closed loop control

Command source:

- Analog input/Pulse + Direction/Modbus RTU/PR mode
- EtherCAT

User configurable inputs and outputs:

- DI/DO
- AI/AO
- A/B/Z-phase differential output/Z-phase OC output
- 2nd encoder inputs
- STO SIL3

- Position Mode
- Velocity Mode
- Torque Mode

ELD2 DC Servo Systems



Power Rating: 50W - 2.5kW
Input Voltage: 24~70VDC
Motor: 40-130mm frame size
Encoder: 1000 ppr, 2500 ppr, 17bit, 23bit
Features:

- Up to 180Amp(127Arms)
- Power brushed DC, and brushless DC/AC servo motors
- STO and Logic Power
- 24VDC Power for Brake

Command source:

- Pulse+Direction / Analog input / Modbus RTU / CANopen
- 16 PR paths

Inputs and Outputs:

- 2 fast pulse input, 5V only
- 4 programmable digital inputs
- 2 programmable digital outputs
- Encoder AB output
- 1 analog input: -10V to +10V

- Position Mode
- Velocity Mode
- Torque Mode

2ELD2 Dual-axis Servo Systems



Power Rating: Each axis 50W - 1.2kW
Input Voltage: 24~70VDC
Motor: 40- 80mm frame size
Encoder: 1000 ppr, 2500 ppr, 17bit, 23bit
Features:

- Dual-axis, each axis current range up to 90Amp(64Arms)
- Power brushed DC, and brushless DC/AC servo motors
- STO and Auxiliary input power
- Direct control of brake
- Save Mounting Space

Command source:

- Pulse+Direction / Analog input / Modbus RTU / CANopen
- 16 PR paths

Inputs and Outputs:

- Max pulse input: 500 kHz
- 4 programmable digital inputs
- 2 programmable digital outputs
- 1 analog input: -10V to +10V

- Position Mode
- Velocity Mode
- Torque Mode

iSV2 Integrated Servo Motors

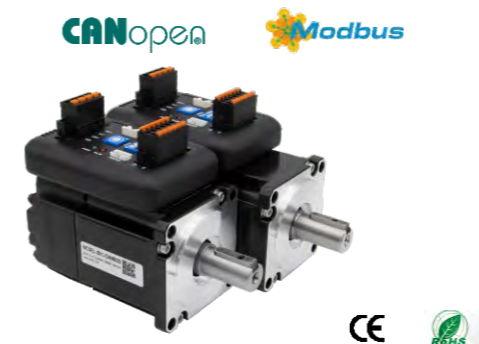

Power Rating: 200W, 400W, 750W
Input Voltage: 24~60VDC
Motor Frame Size: 60mm, 80mm
Encoder: 17bit incremental encoder
Features:

- Highly Intergrated
- Save Mounting Space

Command source:

- Pulse+Direction / Modbus RTU / CANopen

Inputs and Outputs:

- Max pulse input: 500 kHz
- 4 programmable digital inputs
- 2 programmable digital outputs

- Position Mode
- Velocity Mode
- Torque Mode

iSV Integrated Servo Motors



Power Rating: 90W, 130W, 180W
Input Voltage: 24~50VDC
Motor Frame Size: 57mm (NEMA 23)
Encoder: 1000-Line, 16bit
Features:

- Highly Intergrated
- Easy tuning, flexible to control
- Save Mounting Space

Command source:

- Pulse+Direction

Inputs and Outputs:

- 1 programmable digital outputs

- Position Mode

Leadshine Servo Products Quick Selection

Servo Drive	Model	Power (W)	Voltage (VAC)	Dimensions (mm)	Weight (kg)	Command Source				Command Source		STO	Encoder Output	Brake Output	Digital Inputs (Points)	Digital Outputs (Points)	Analogue Input	Analogue Output	Matched Servo Motors	
						Pulse+Dir	Analog Input	RS485		EtherCAT	CANopen									
AC Servo Drive EL6 Series	EL6-D400Z	400	1 Phase 220	175*156*40	0.9	✓									4	3			ELM1 and ELM2 Servo Motors Please refer to page 48 to 60 for more information on matching servo motors	
	EL6-RS400Z					✓		✓					✓		4	3				
	EL6-CAN400Z												✓		4	3				
	EL6-D750Z	750		175*156*50	1.1	✓									4	3				
	EL6-RS750Z					✓		✓				✓		4	3					
	EL6-CAN750Z												✓		4	3				
	EL6-D1000Z	1000		175*156*50	1.2	✓									4	3				
	EL6-RS1000Z					✓		✓				✓		4	3					
	EL6-CAN1000Z												✓		4	3				
AC Servo Drive EL7-RS Series - 220VAC	EL7-RS400P	400	1 Phase 220	175*156*40	0.9	✓	✓	✓				✓		8	5	2	1			
	EL7-RS750P	750		175*156*50	1.1	✓	✓	✓				✓		8	5	2	1			
	EL7-RS1000P	1000		175*156*50	1.2	✓	✓	✓				✓		8	5	2	1			
	EL7-RS1500P	1500	1 Phase/ 3 Phase 220	175*156*80	2.3	✓	✓	✓				✓		8	5	2	1			
	EL7-RS2000P	2000			2.3	✓	✓	✓				✓		8	5	2	1			
AC Servo Drive EL7 Series - 220VAC	EL7-EC400F	400	1 Phase 220	175*156*40	0.9					✓	✓	✓		4	3					
	EL7-EC750F	750		175*156*50	1.2						✓	✓	✓		4	3				
	EL7-EC1000F	1000		175*156*50	1.2						✓	✓	✓		4	3				
	EL7-EC1500F	1500		175*156*80	2.3						✓	✓	✓		4	3				
	EL7-EC2000F	2000									✓	✓	✓		4	3				
AC Servo Drive EL7 Series - 380VAC Models	EL7-EC750FT	750	3 Phase 380	179*175*55	1.3					✓	✓	✓		4	3					
	EL7-EC1000FT	1000									✓	✓	✓		4	3				
	EL7-EC1500FT	1500										✓	✓	✓		4	3			
	EL7-EC2000FT	2000										✓	✓	✓		4	3			
	EL7-EC3000FT	3000		179*175*80	1.9						✓	✓	✓		4	3				
	EL7-EC4400FT	4400										✓	✓	✓		4	3			
	EL7-EC5500FT	5500				230*250*90	3.3						✓	✓	✓		4	3		
	EL7-EC7500FT	7500											✓	✓	✓		4	3		

Servo Drive	Model	Power (W)	Voltage (VAC)	Dimensions (mm)	Weight (kg)	Command Source				Command Source		STO	Encoder Output	Brake Output	Digital Inputs (Points)	Digital Outputs (Points)	Analogue Input	Analogue Output	Matched Servo Motors
						Pulse+Dir	Analog Input	RS485		EtherCAT	CANopen								
AC Servo Drive EL8 Series	EL8-EC400F	400	1 Phase/ 3 Phase 220	150*150*43	1.0					✓		✓	✓	✓	8	3	2	2	ELM1 and ELM2 Servo Motors Please refer to page 48 to 60 for more information on matching servo motors
	EL8-RS400F					✓	✓	✓			✓	✓	✓	10	6	3	2		
	EL8-EC750F	750		150*160*55	1.2					✓		✓	✓	✓	8	3	2	2	
	EL8-RS750F					✓	✓	✓			✓	✓	✓	10	6	3	2		
	EL8-EC1000F	1000		150*160*55	1.2					✓		✓	✓	✓	8	3	2	2	
	EL8-RS1000F					✓	✓	✓			✓	✓	✓	10	6	3	2		
	EL8-EC1500F	1500		183*160*80	2.0					✓		✓	✓	✓	8	3	2	2	
	EL8-RS1500F					✓	✓	✓			✓	✓	✓	10	6	3	2		
	EL8-EC2000F	2000		183*160*80	2.0					✓		✓	✓	✓	8	3	2	2	
	EL8-RS2000F					✓	✓	✓			✓	✓	✓	10	6	3	2		

Servo Drive	Model	Power (W)	Main Voltage (VDC)	Logic Power (VDC)	Dimensions (mm)	Weight (kg)	Command Source				Command Source		*STO	Encoder Output	Brake Output	Digital Inputs (Points)	Digital Outputs (Points)	Matched Servo Motors
							Pulse+Dir	Analog Input	RS485		EtherCAT	CANopen						
DC Servo Drive ELD2 Series	ELD2-RS7005	200	24-70		118*75.5*25.5	0.2	✓	✓	✓							4	2	*ELVM Servo Motors For more information please refer to pages 53 to 62 *3rd Party Brushless /Brushed Motor
	ELD2-CAN7005B				140*79.5*25.5	0.3					✓		✓	4	2			
	ELD2-RS7010	400			118*75.5*25.5	0.2	✓	✓	✓				✓	4	2			
	ELD2-CAN7010B				140*79.5*25.5	0.3					✓	✓	4	2				
	ELD2-RS7015B	600			175*100.5*31	0.7	✓	✓	✓				✓	✓	4	2		
	ELD2-CAN7015B					0.7					✓	✓	4	2				
	ELD2-RS7020B	750			0.7	✓	✓	✓				✓	✓	4	2			
	ELD2-CAN7020B				0.7					✓	✓	4	2					
	ELD2-RS7030B	1200			0.7	✓	✓	✓				✓	✓	4	2			
	ELD2-CAN7030B				0.7						✓	✓	4	2				
	ELD2-RS7040B	1500			194*103*41	0.9	✓	✓	✓			✓	✓	✓	4	2		
	ELD2-CAN7040B					0.9						✓	✓	4	2			
	ELD2-RS7060B	2500			0.9	✓	✓	✓				✓	✓	✓	4	2		
	ELD2-CAN7060B				0.9							✓	✓	4	2			
DC Servo Drive 2ELD2 Series	2ELD2-RS7020B	750*2	24-70	24-70	194*103*41	1.0	✓		✓			✓		✓	4*2	2*2		
	2ELD2-CAN7020B					1.0		✓				✓	✓	4*2	2*2			
	2ELD2-RS7030B	1200*2				1.0	✓		✓			✓	✓	4*2	2*2			
	2ELD2-CAN7030B					1.0		✓				✓	✓	4*2	2*2			

Note: *STO function is in the process of certification

AC Servo Drive Series

Performance

Cost-effective AC Servo EL6



- Speed frequency response up to 2kHz
- Power range up to 1kW
- Connectors with lock screws for convenient reliable connections

EL6-D***Z	Pulse+dir
EL6-RS***Z	Pulse+dir /Modbus RTU
EL6-CAN***Z	CANopen

General Purpose AC Servo EL7



- Speed frequency response up to 3.2kHz
- Power range up to 7.5kW
- 220VAC/380VAC input
- Modbus RTU/EtherCAT/Profinet
- Safety torque off with SiL3(optional)
- Auto tuning

EL7-EC***	EtherCAT, 220/380VAC
EL7-PN***	Profinet, 220/380VAC
EL7-RS***	Pulse+Dir/Modbus RTU/Analog input 220/380VAC

High performance AC Servo EL8



- Frequency response up to 3.5kHz
- Power rating ranging up to 2kW
- Pulse input frequency at the max of 8Mbps
- Easy servo tuning
- Safe Torque Off (IEC61508 SIL3)
- Modbus RTU/Pulse + Direction/ EtherCAT
- Hybrid control mode(RS)

EL8-EC***F	EtherCAT
EL8-RS***F	Pulse+direction/Modbus RTU/Analog input

Series

AC Servo Motor Series

Performance

Enhanced ELM2 Series



- Frame of 40/60/80/100/130/180
- Power range from 50W-7500W
- 23-bit optical multi-turn encoder
- IP65/IP67
- 220VAC/380VAC

Standard ELM1 Series



- Frame of 40/60/80
- Power range from 50W-1000W
- 23-bit magnetic multi-turn encoder
- IP67
- 220VAC

Series

AC Servo Drives EL6 Series

- Power rating: 100W - 1kW
- 220 VAC input
- Automatic motor identification
- Easy configuration
- Cost effective with stable performance



EL6 Series include cost-effective AC servo drives designed for accurate positioning control. They can power up to 1kW AC servo motors and are ideal for many OEM applications. Many advanced features are implemented such as MFC, vibration suppression, Multi - mode filter function, etc. When combined with Leadshine servo motors with 17 or 23-bit high resolution encoders, they can provide excellent performance to your control systems.

EL6-D EL6-D Servo Drives

Position/Internal velocity mode

- 5V differential pulse(500kHz) / 24V single-ended pulse(200kHz)
- Digital inputs and digital outputs allow sink and source connections
- Supporting 17-bit magnetic single-turn encoder / 23-bit optical multi-turn encoders
- GUI Software - MotionStudio
- Online Inertia Ratio Identification
- Connectors with lock screws for convenient reliable connections

EL6-RS EL6-D Modbus Servo Drives

Position/Velocity Mode



- RS485 based on Modbus-RTU protocol
- Encoder signal output
- 5V differential pulse(500kHz) / 24V single-ended pulse(200kHz)
- Digital inputs and digital outputs allow sink and source connections
- Supporting 17-bit magnetic single-turn encoder / 23-bit optical multi-turn encoders
- GUI Software - MotionStudio
- Online Inertia Ratio Identification
- Connectors with lock screws for convenient reliable connections

EL6-CAN EL6-CAN CANopen Servo Drives

Profile Position/Profile Velocity/Profile Torque/Homing



- CANopen (CIA 301 & DS402)
- 4 RPDO & 4 TPDO
- Encoder signal output
- Digital inputs and digital outputs allow sink and source connections
- Supporting 17-bit magnetic single-turn encoder / 23-bit optical multi-turn encoders
- GUI Software - MotionStudio
- Inertia load identification online
- Connectors with lock screws for convenient reliable connections

EL6 Servo System Performance

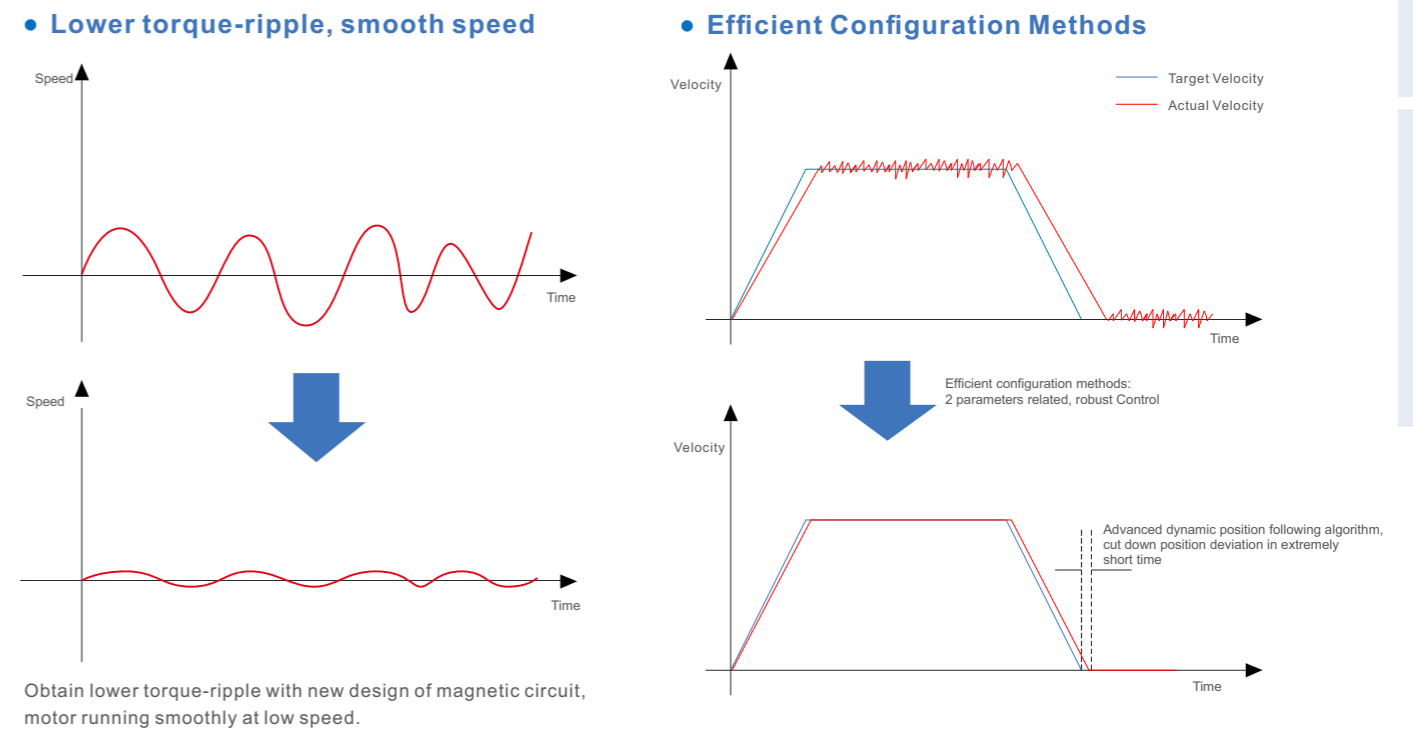

• Adaptive Notch Filter

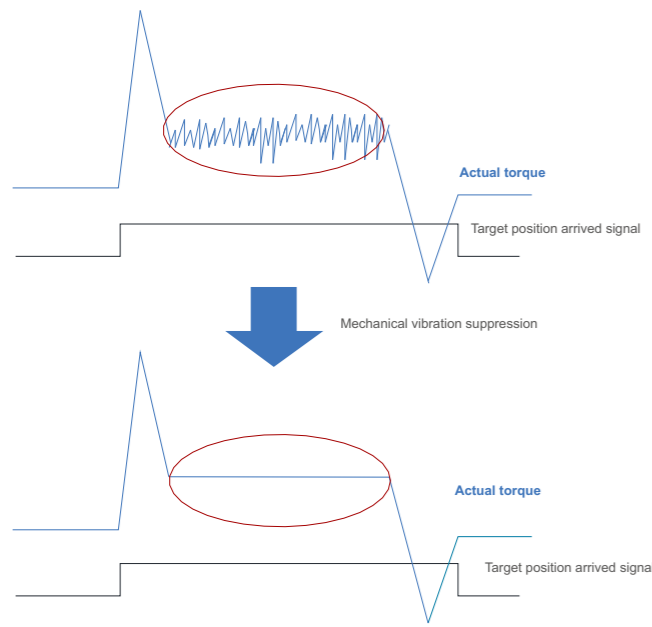

- 4 Adaptive Notch Filter
- Automatically / Manually Notch Filter Setting
- Notch Width Selectable
- Quick setting suppresses mechanical vibration, saving labor cost

• P-N Junction

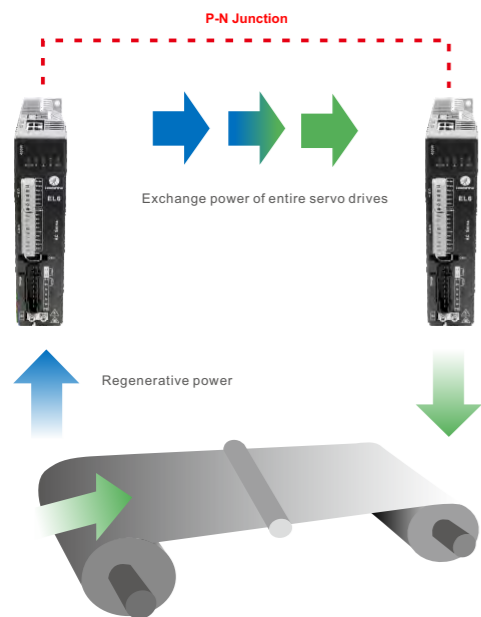

Directly connect the DC link circuit of entire servo drives to exchange power.
In a system having a powering (driving) shaft and regenerating (back tension) shaft such as the winder/unwinder unit, the power consumption of the entire system can be reduced.

• Anti-Vibration Filter

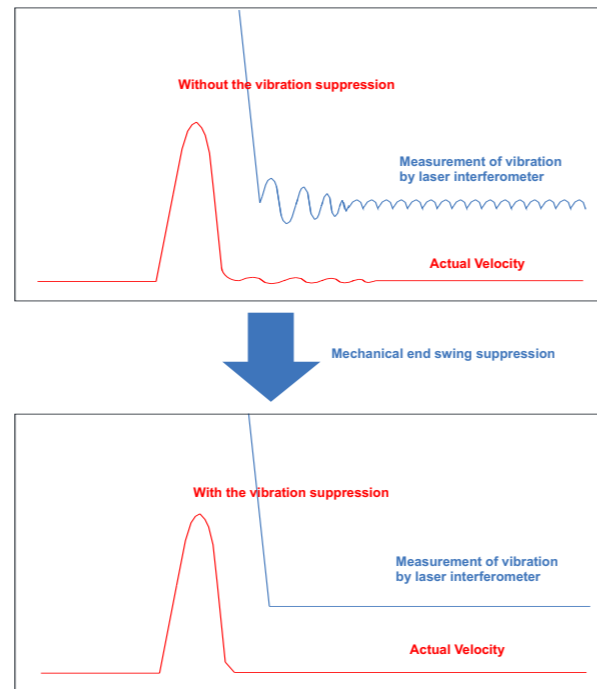

For mechanical equipment with lower stiffness, it is easy to produce low frequency vibration of less than 200Hz, which can be inhibited by mechanical end swing suppression, to realize the high-tempo operation of the equipment.

• PR-Mode

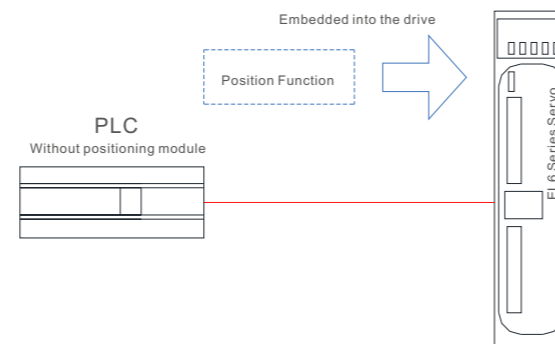

EL6-RS series embedded with 16 paths motion which setup internally, combined with position/velocity/homing/Jog/E-Stop/Limit switch.

• RS485 Communication Control / Digital Input Control

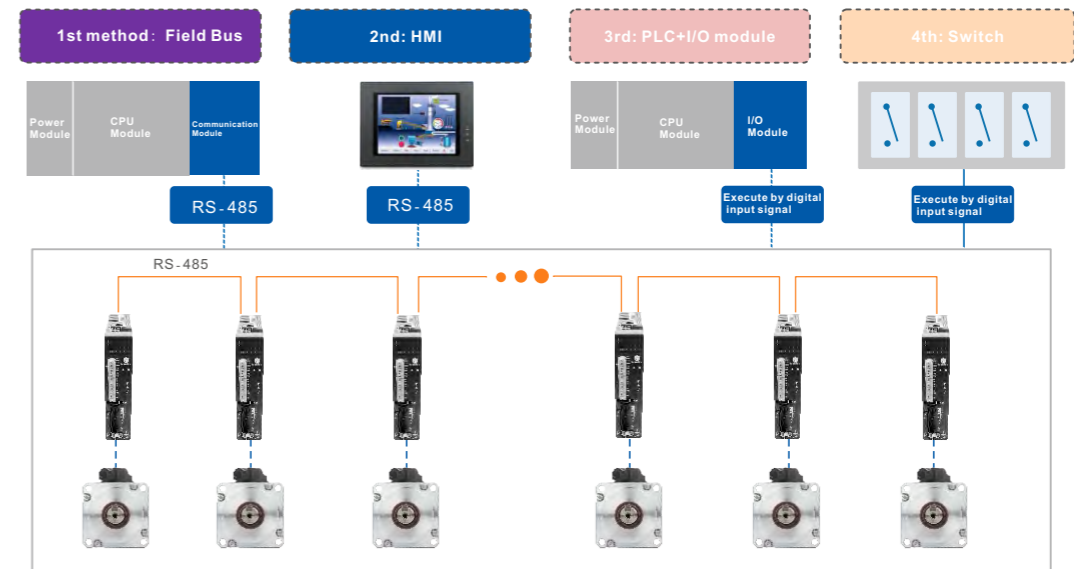

• CANopen

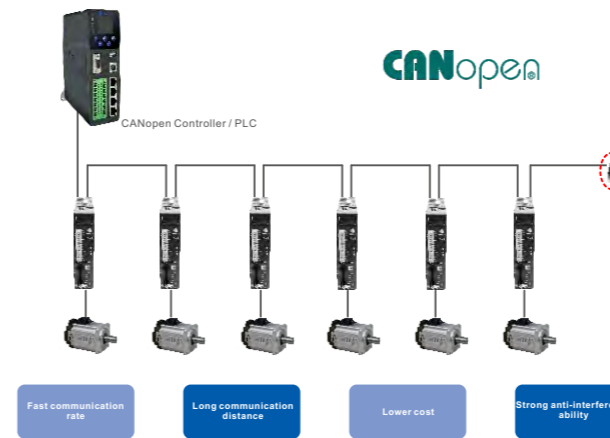

- RJ45 terminal for CANopen communication, LAN cable connection
- CiA 303-1 Cabling and connector pin assignment
- CiA 301 Application Layer and Communication Profile
- CiA 402 Device Profile Drives and Motion Control
- SDO, PDO, SYNC, EMCY, NMT, Heartbeat

Part Numbers

EL6 - D 1000 Z

Series Num		Version	
EL6	Servo drive series	Z	Standard Version
Command Source		Rated Output Power	
D	Pulse+Direction	100	100W
RS	RS485 (Pulse+Direction /Modbus-RTU)	400	400W
CAN	CANopen	750	750W
		1000	1000W

Specifications

Drive model	EL6-D400Z EL6-RS400Z EL6-CAN400Z	EL6-D750Z EL6-RS750Z EL6-CAN750Z	EL6-D1000Z EL6-RS1000Z EL6-CAN1000Z
Rated output power	400W	750W	1000W
Rated output current [Arms]	3	5.2	7
Max output current [Arms]	13	18.4	26.5
Dimensions(mm)	175*168*40	175*168*50	175*168*50
Main power/Control power	Single phase 220V -15%~+10% 50/60Hz		
Control methods	IGBT SVPWM sinusoidal wave control		
Feedback mode	Bus encoder: RS485 protocol		
Input pulse	0-500kHz,5V differential input ; 0-200kHz,24V single-ended input		
Electronic gear ratio	1~8388608/1~8388608		
Speed frequency response	3.1kHz		
Input signal	DI: 4 programmable digital inputs, allows sink connection/source connection Servo enable, over-travel inhibition, gain switching, command pulse inhibition, speed zero clamp, deviation counter clear, alarm clear		
Output signal	DO: 3 programmable digital outputs(2 single-ended, 1 differential) Alarm output, servo-ready, at-speed, zero-detection, velocity coincidence		
Encoder signal output	A phase, B phase, Z phase, long-distance drive mode output		
Alarm function	Over-voltage, under-voltage, over-current, over-load, encoder error, position deviation error, brake alarm, limit alarm, over-speed error etc.		
Operation and display	Jog, trapezoidal wave test, each parameter and input output signal can be modified and saved, five-bit LED to display rotational speed, current, position deviation, drive type version and address ID value etc.		
GUI Software	Can adjust the parameters of current loop, velocity loop, position loop, and change the value of input and output signals and the parameter of motor and save the values to the files which can be downloaded and uploaded, monitor the waveform of velocity and position in the ladder.		
Communication interface	RS232: Based on Modbus protocol RS485: Based on Modbus protocol		
Brake mode	Built-in brake 50Ω/50W		
Adapt load inertia	Less than 20 times motor inertia		
Weight	About 1.5-3kg		
Environment	Environment: Avoid dust, oil fog and corrosive gases		
	Ambient Temp: 0 to +40℃		
	Humidity: 40% RH to 90%RH, no condensation		
	Vibration: 5.9 m/s ² MAX		
	Storage Temperature: -20~80℃		
	Installation: Vertical installation		

Servo drive series	EL6-D***Z	EL6-RS***Z	EL6-CAN***Z
Control methods	<ul style="list-style-type: none"> Position control Internal Velocity control JOG 	<ul style="list-style-type: none"> Position control Velocity control Torque control JOG 	<ul style="list-style-type: none"> PP(Profile Position) PV(Profile Velocity) PT(Profile Torque) HM(Homing)
Encoder output	X	√	√
Digital input	4 programmable digital inputs (allow sink connection/source connection)		
Digital output	3 programmable digital outputs(2 single-ended, 1 differential)		
Network	--	Modbus RTU (LAN CABLE-RJ45 terminal)	CANopen (LAN CABLE-RJ45 terminal)
Maximum frequency Of pulse input	5V differential , 0~500kHz 24V single-ended, 0~200kHz	5V differential , 0~500kHz 24V single-ended, 0~200kHz	--

Motion Studio - GUI Software

- Complex parameter displaying, motion status monitoring, servo tuning, etc. have been consolidated into an easy-to-use PC software.
- Tabular display for easy monitoring and modify servo parameter settings.
- Easy to adjust control gains manually for better performance.
- Motion State Monitoring and accurate 4-channel wave displays.
- Easy to set the values of object dictionary for CANopen drives.
- Easy to read /save / download / compare / reset servo parameters.

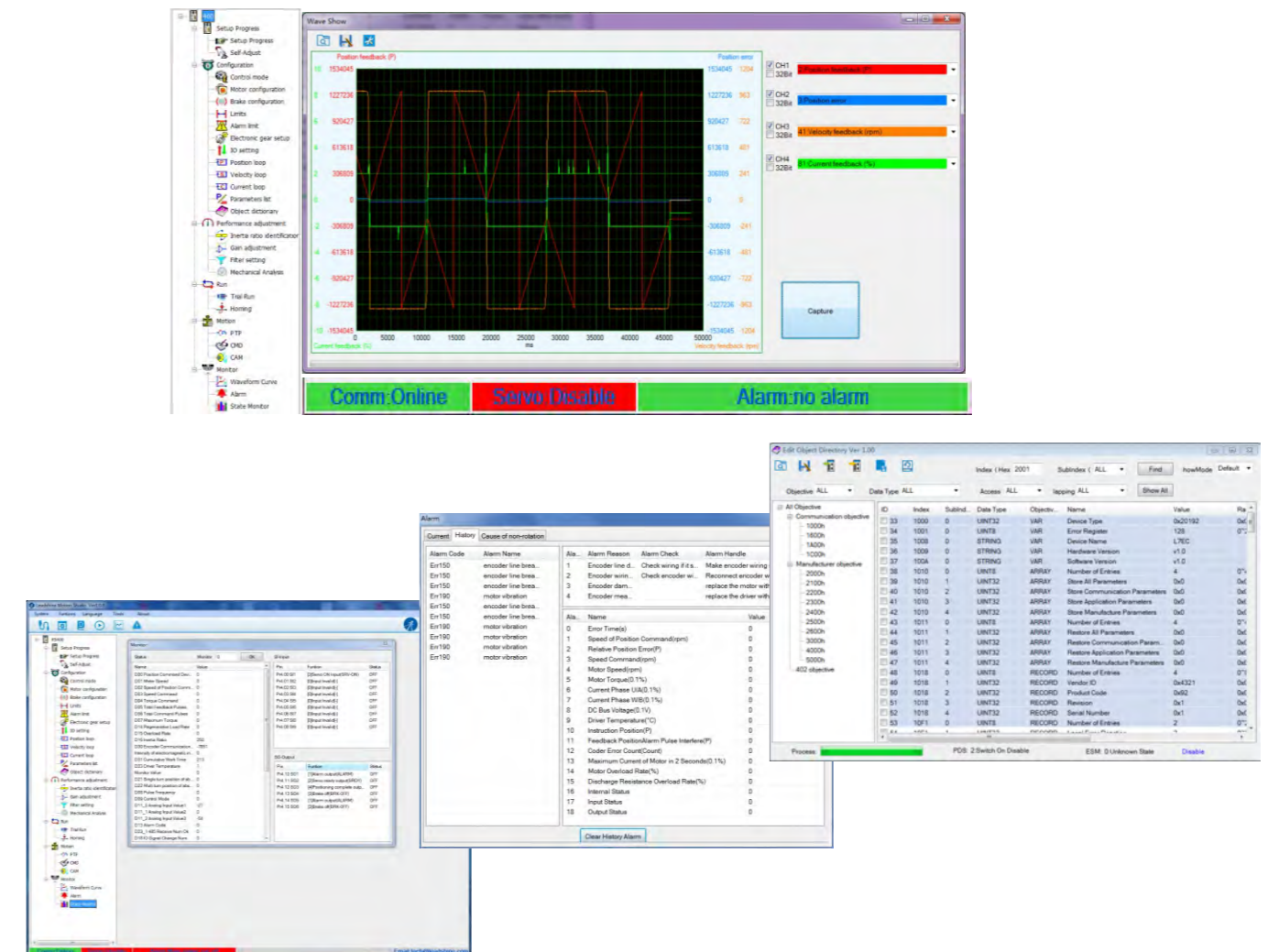

Servo Drive Pin Assignments

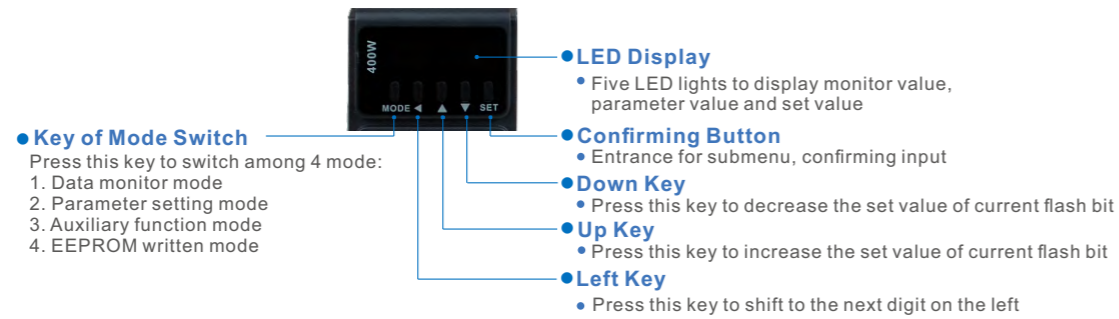
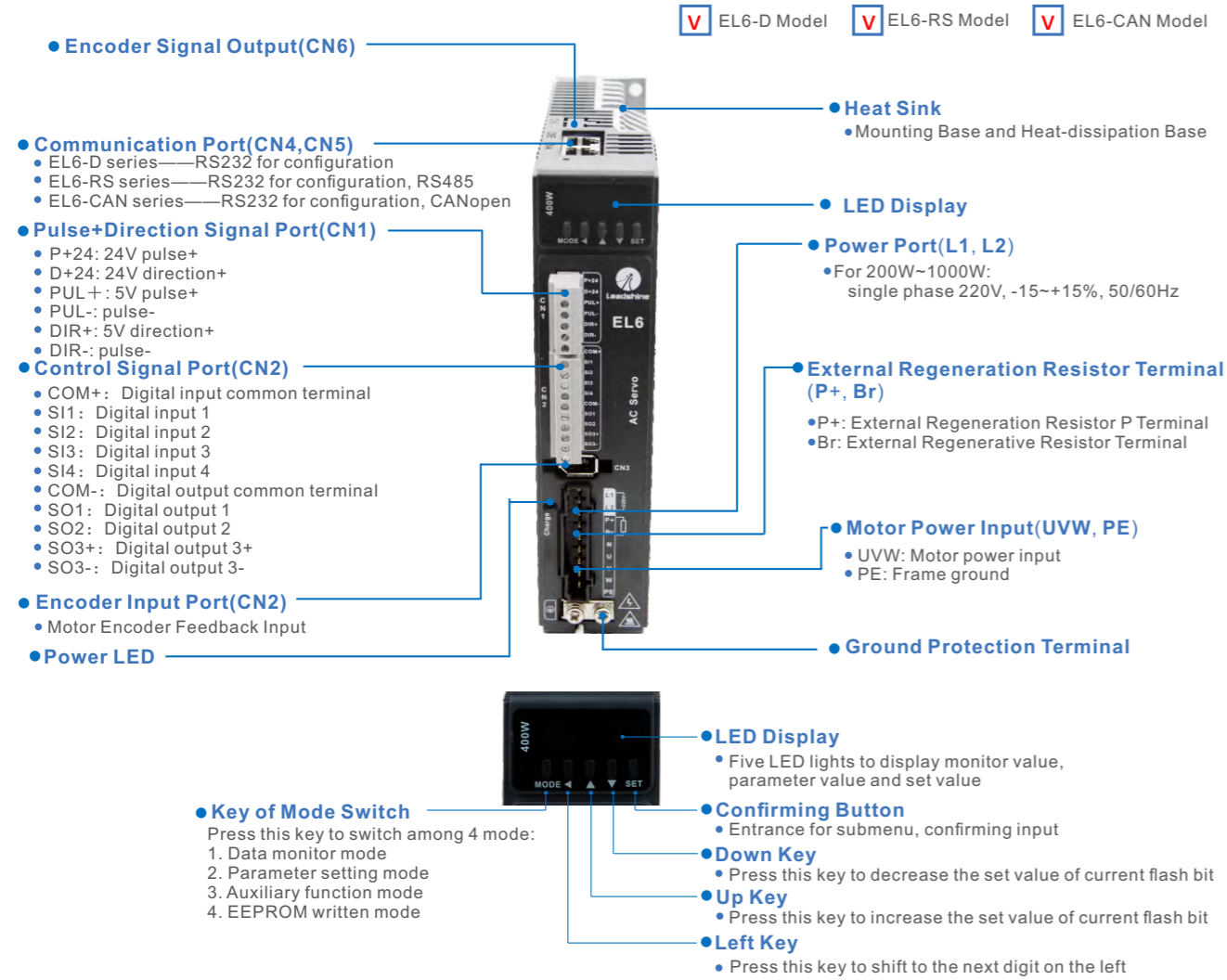

External Regeneration Resistors

Type	Power	Resistance
RXLG-50W	50W	100Ω
RXLG-100W	100W	100Ω
RXLG-200W	200W	50Ω
RXLG-400W	400W	50Ω
RXLG-800W	800W	50Ω

Dimensions

Unit: mm

• 400W

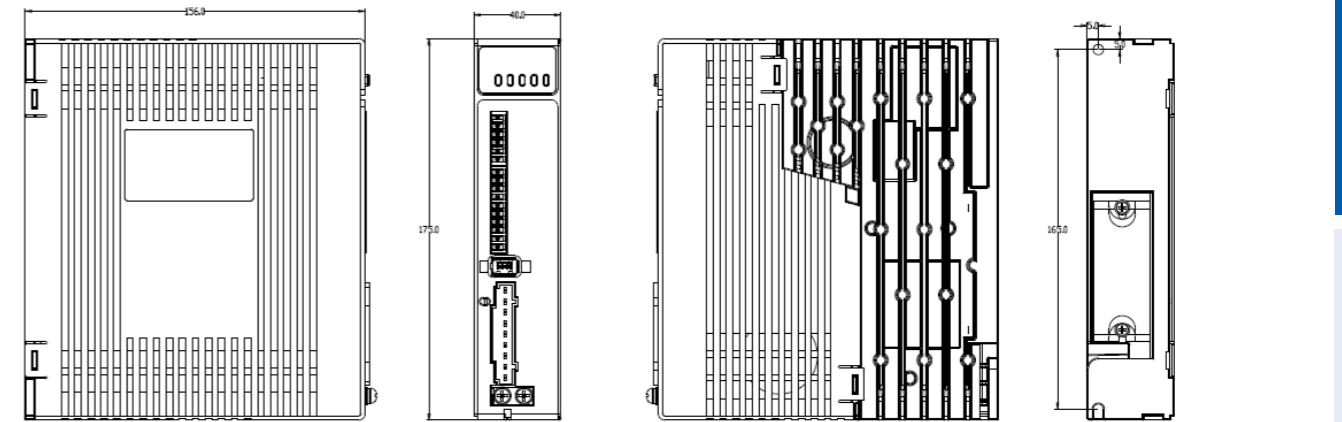

• 750W

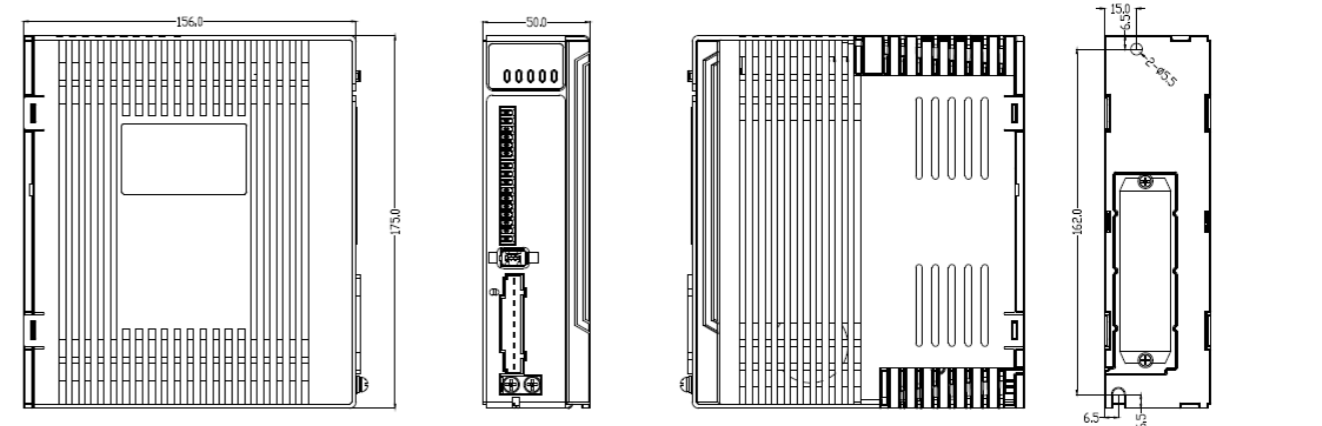

• 1000W

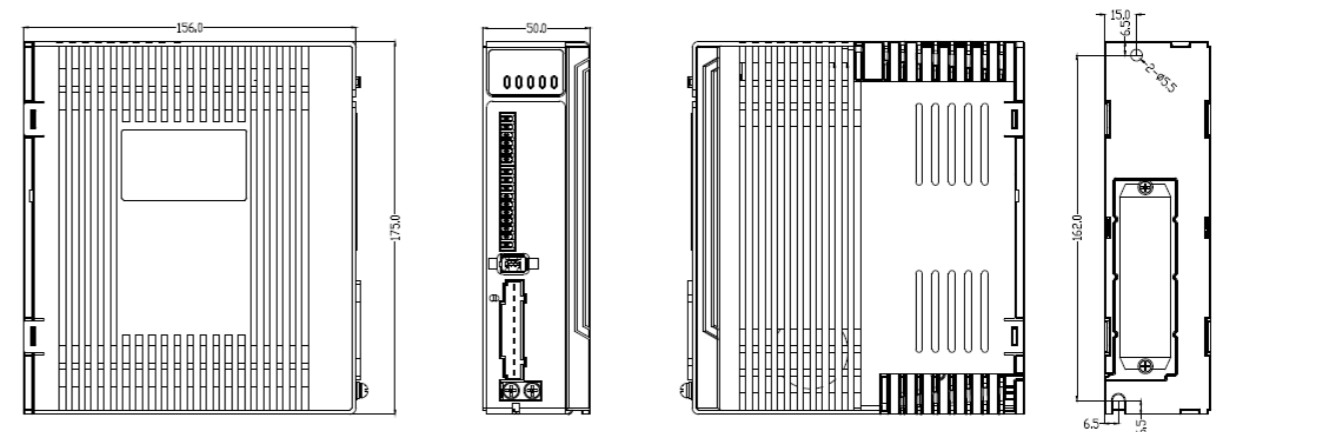

System Wirings

• Position/Torque/Velocity Control

- EL6-D Model
- EL6-RS Model
- EL6-CAN Model

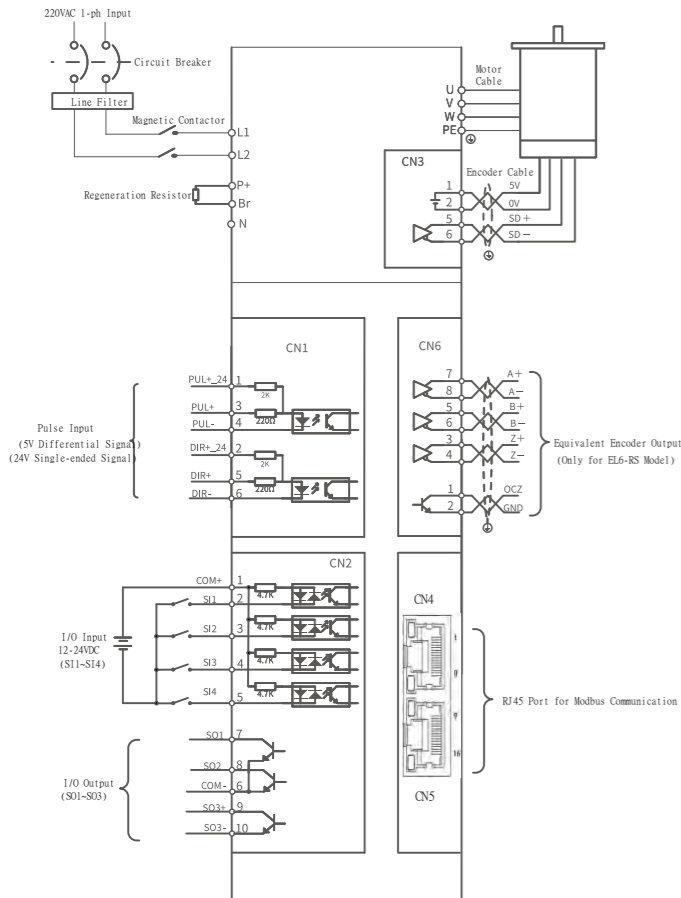

• CANopen Control

- EL6-D Model
- EL6-RS Model
- EL6-CAN Model

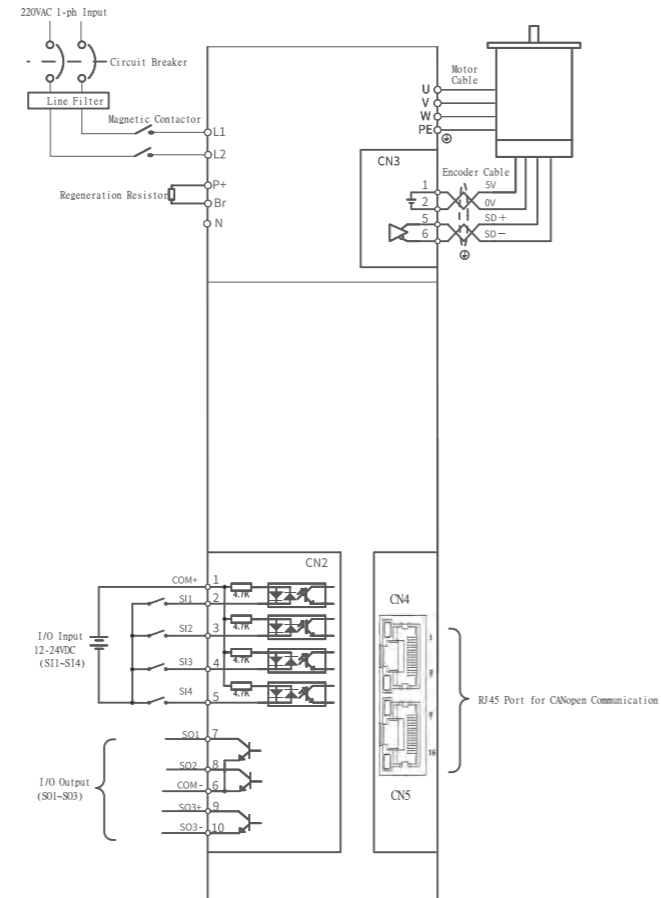

AC Servo Drives

EL7-ECF Series-220/380VAC Models



- Power Rating: 220VAC models: 400W-1KW
380VAC models: 750W-7.5kW
- 1ph 220VAC/3ph 380VAC
- ETG COE + EtherCAT DSP402 communication protocol
- Leadshine Servo Motors automatically identified

EL7-EC Series AC servo products are high performance AC digital servo which is designed for position/velocity/torque high accurate control with power rating ranging up to 2kW for 220VAC models and 7.5kW for 380VAC models which provides a perfect solution for different applications with easy tuning process.



EtherCAT

EL7 Series EL7-EC AC Servo Drives

Position/Velocity/Torque Mode

- EtherCAT—CiA402, CoE
- Speed frequency response up to 3.2kHz
- 23-bit optical multi-turn encoder
- Built-in dynamic brake
- GUI Software - Motion Studio

High Precision

- Up to 23-bit(8388608 ppr) high resolution encoder.
- Motors come with up to 23-bit (8388608 ppr) high resolution encoders are also available for applications require higher precision, smoother movement and lower torque ripple

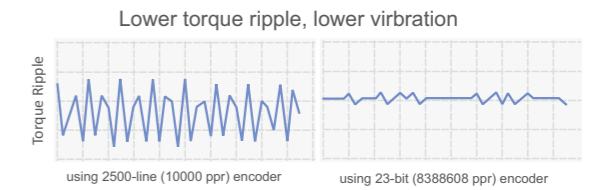

Excellent Position Following Capability

- By adopting load identification and torque feedforward advanced control algorithms, very small velocity ripple and position following error can be achieved. It is a great feature of the EL7 when multi-axis synchronization such as interpolations are required.

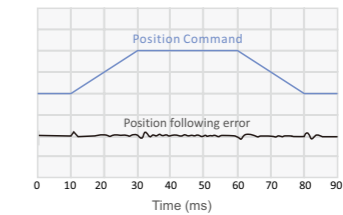

Vibration Suppression

- Adaptive filter makes the notch filter frequency automatically follow the machine resonance frequency.
- Can suppress vibration occurring at both starting and stopping in low stiffness machine.
- Suppress vibration frequency up to 1500 Hz.

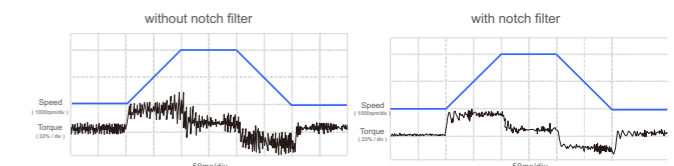

Command Signal Smoothing

- Command signal smoothing can soften the effect of immediate change in velocity and direction, delivering smoother movement and longer lifetime.

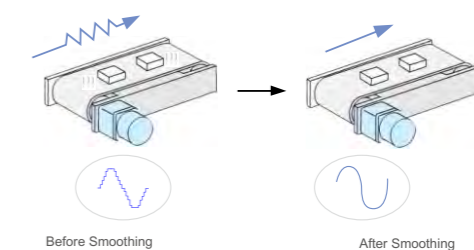

AC Servo Systems

DC Servo Systems

Integrated Servo Motors

Power Supply

Part Numbers

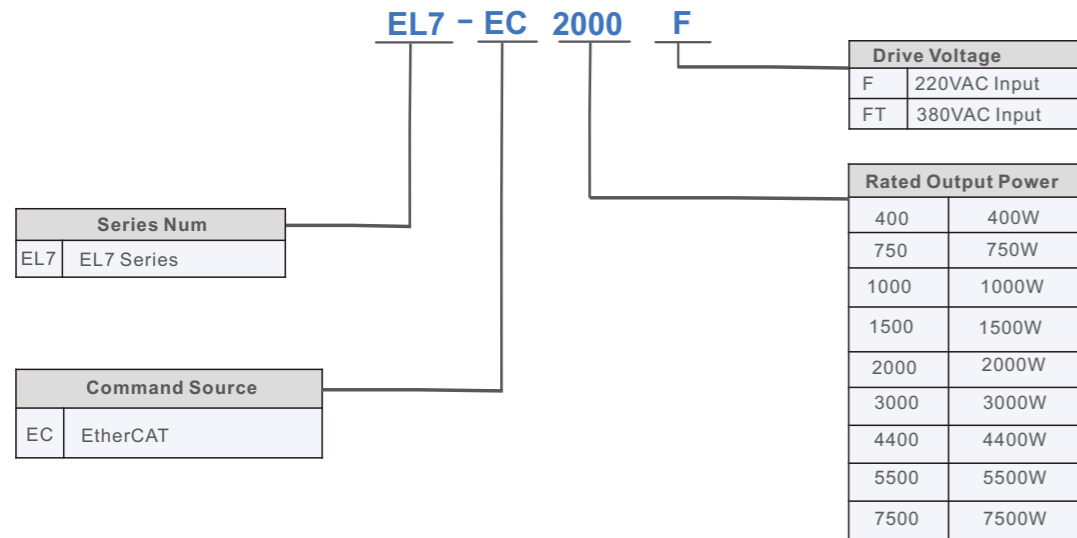

Specifications

EL7-EC Series – 220VAC

	EL7-EC400F	EL7-EC750F	EL7-EC1000F	EL7-EC1500F	EL7-EC2000F
Rated Power (W)	400	750	1000	1500	2000
Rated Current (A)	3.5	5.5	7	<i>Coming Soon!</i>	
Peak Current (A)	9.2	16.6	18.7		
Size (mm)	40*175*156	50*175*156			
Main Power Supply	Single phase AC 220V, -15%~+10%, 50/60Hz				
Control Circuit Power Supply					

EL7-EC Series – 380VAC

Servo Drive Model	EL7-EC750FT	EL7-EC1000FT	EL7-EC1500FT	EL7-EC2000FT	EL7-EC3000FT	EL7-EC4400FT	EL7-EC5500FT	EL7-EC7500FT
Rated Power (W)	750W	1000W	1500W	2000W	3000W	4400W	5500W	7500W
Rated Current (A)	2.7	3.5	5.4	8.4	11.9	16.5	20.8	25.7
Peak Current (A)	8.6	10.6	14.9	24.8	33.2	38.9	51.6	63.6
Size (mm)	55*175*179		85*175*179		89*250*230			
Main Power Supply	Three phase AC 380V~440V, -15%~+10%, 50/60Hz							
Control Circuit Power Supply	Single phase AC 380V~440V, -15%~+10%, 50/60Hz							
Control								
Drive Mode	IGBT PWM sinusoidal wave drive							
Control Mode	Position	Profile Position Mode (PP)						
		Cyclic Synchronous Position Mode (CSP)						
		Homing Mode (HM)						
	Velocity	Profile Velocity Mode (PV)						
		Cyclic Synchronous Velocity Mode (CSV)						
	Torque	Profile Torque Mode (PT)						
		Cyclic Synchronous Torque Mode (CST)						

Inputs and Outputs		
Feedback Method	RS485 protocol; 23-bit multi-turn absolute magnetic/optical encoder	
Control Mode	Digital Input	4 Digital Inputs (Supports NPN and PNP) Configurable input signals under EtherCAT mode: 1. Clear Alarm (A-CLR) 2. Positive limit switch (POT) 3. Negative limit switch (NOT) 4. Homing switch (HOME-SWITCH) 5. Emergency stop (E-Stop)
	Digital Output	3 Digital Outputs (2 single-ended, 1 differential) Configurable output signals under EtherCAT mode: 1. Alarm (ALM) 2. Servo ready (SRDY) 3. External brake off (BRK-OFF) 4. Positioning completed (INP) 5. Velocity at arrival (AT-SPEED) 6. Torque limiting command (TLC) 7. Zero speed position (ZSP) 8. Velocity coincidence (V-COIN) 9. Position command (P-CMD) 10. Velocity limit (V-LIMIT) 11. Velocity command (V-CMD) 12. Servo enabled (SRV-ST) 13. Homing done (HOME-OK)
	Encoder Output	Encoder ABZ differential pulse output
	Probe Input	2 high speed probe inputs: EXT1+/EXT1-, EXT2+/EXT2-
	Communication Port	USB Mini
	EtherCAT	EtherCAT, Communication up to 128 axes to a host
Others		
Software	Driver tuning through Motion Studio Ver. 1.4.x. Parameters tuning in current loop, position loop, velocity loop; Modify I/O signal and motor parameters; Variables(velocity, position deviation, etc.) monitoring using step diagrams	
Driver Front Panel	5 push buttons and 8-segments display	
Holding brake	Built-in (Supports external brake)	
Safety Protection	Overcurrent. Overvoltage. Undervoltage. Overheat. Overload. Overtravel. Single-Phasing. Regenerative resistor error. Position deviation error. Encoder feedback error. Excessive braking rate. EEPROM error.	
Safe Torque Off (STO) function	Available for all EL7EC-F series products	
Environment	Temperature	Storage: -20-80°C (Condensation free); Installation: 0-55°C (Not frozen)
	Humidity	Under 90%RH (Condensation free)
	Altitude	Up to 1000m above sea level
	Vibration	Less than 0.5G (4.9m/s ²) 10-60Hz (non-continuous working)
	IP ratings	IP20

Motion Studio - GUI Software

- Information such as parameter setting and monitoring are consolidated easily just by connecting a personal computer to servo drive.
- Display parameter setting in list or visual formats, and set parameters by selecting from the drop down list
- Adjust control gain finely on the [Tuning] window manually for better performance.
- State monitoring and 4 channel wave showing with high accuracy.
- Easy to set the values of object dictionary for drive with EtherCAT version.
- Easy to read/save/download/compare/reset all parameters.

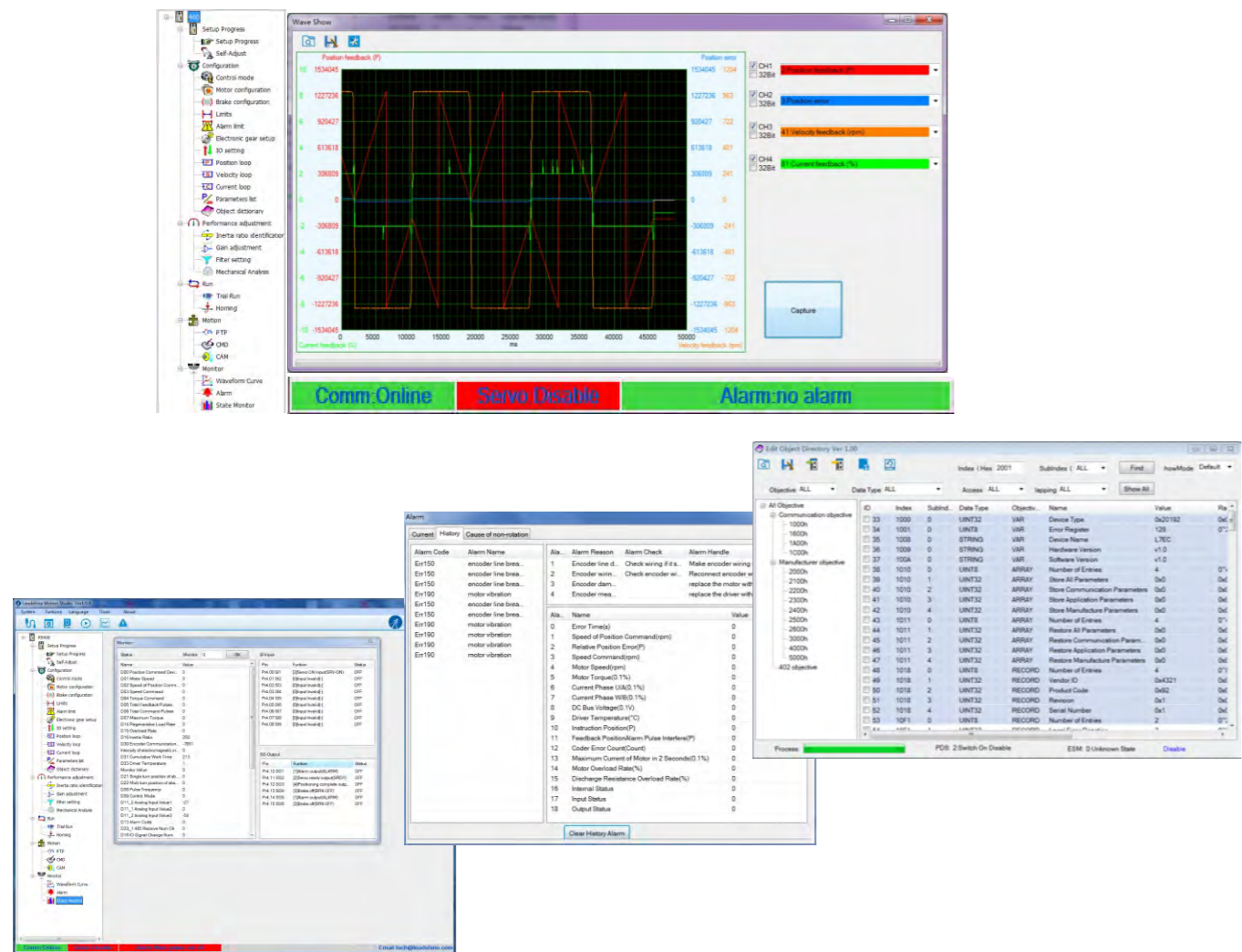

Servo Drive Pin Assignments

EL7-EC Series – 220VAC

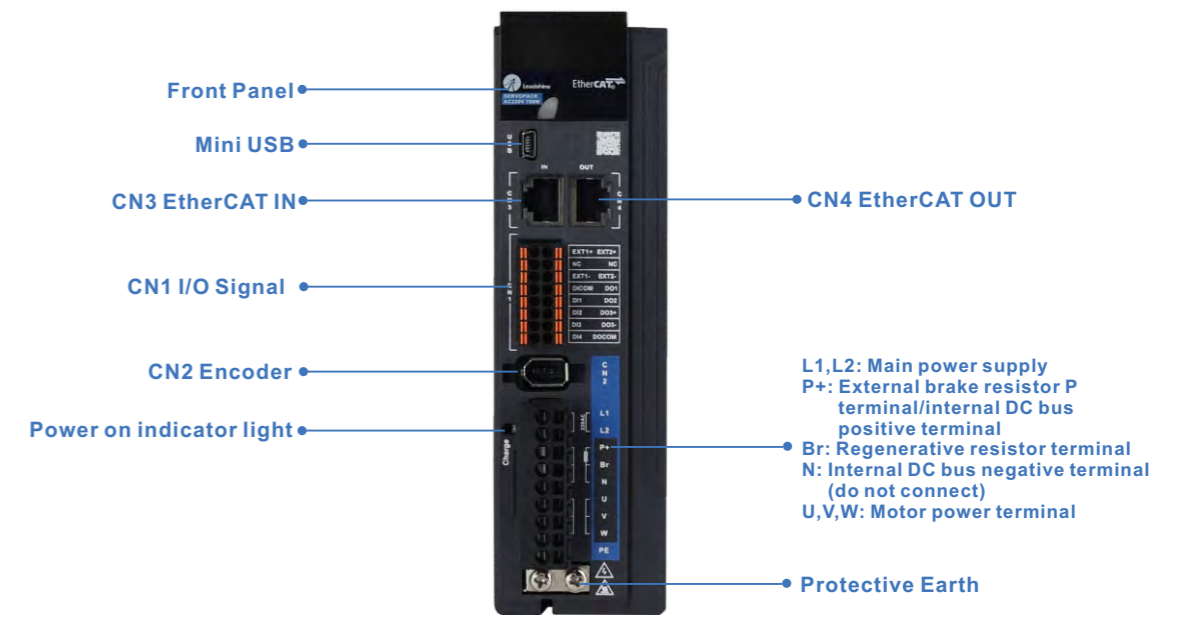

EL7-EC Series – 380VAC

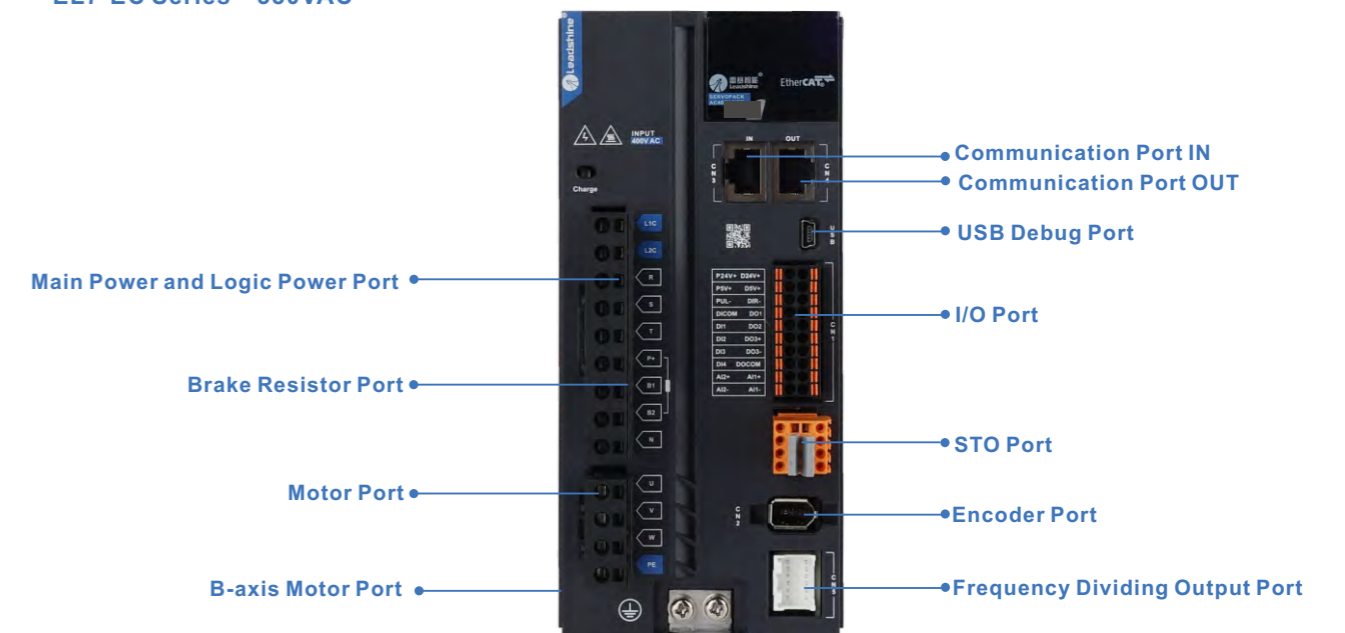

External Regeneration Resistors

Type	Power	Resistance
RXLG-50W	50W	100Ω
RXLG-100W	100W	100Ω
RXLG-200W	200W	50Ω
RXLG-400W	400W	50Ω
RXLG-800W	800W	50Ω

Dimensions

• 220V 400W

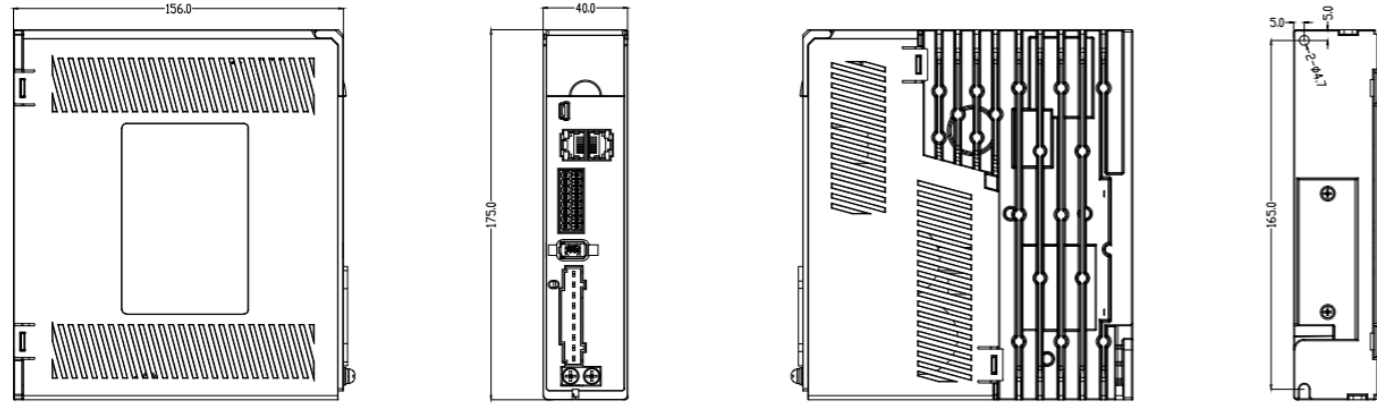

• 380V 750W/1kW/1.5kW

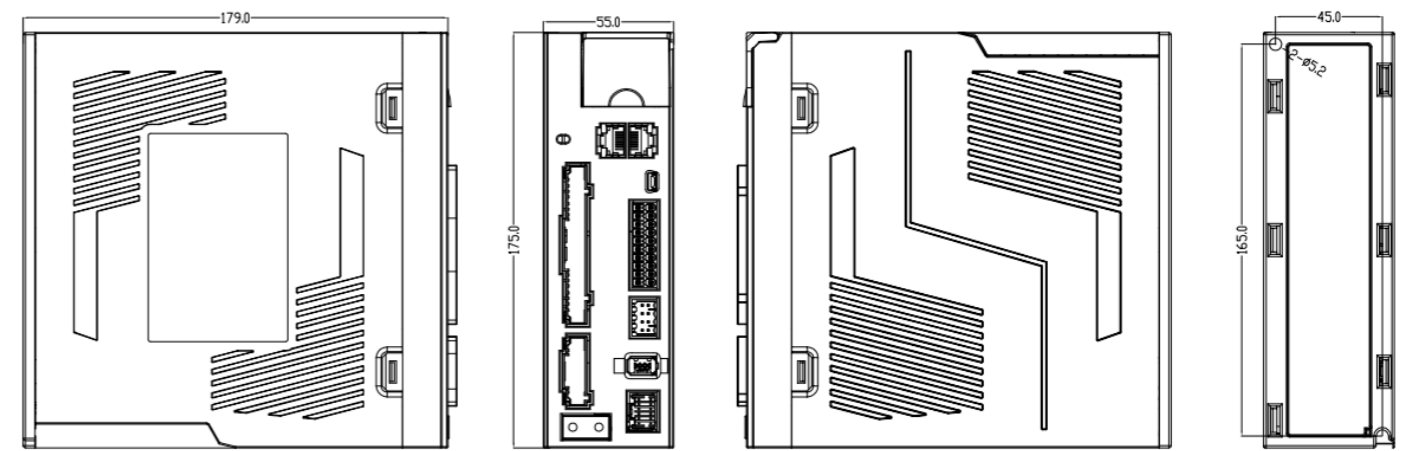

• 220V 750W/1kW

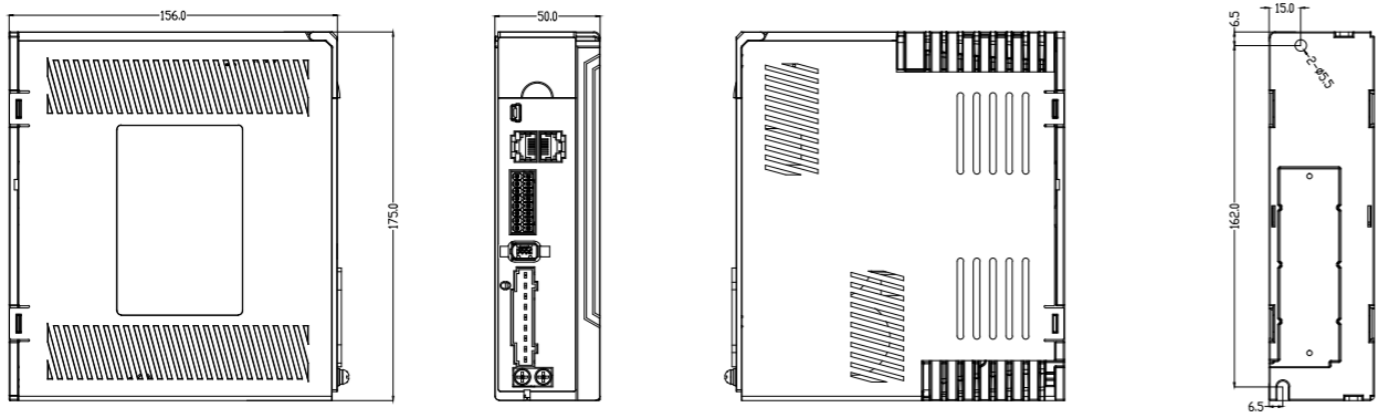

• 380V 2kW/3kW

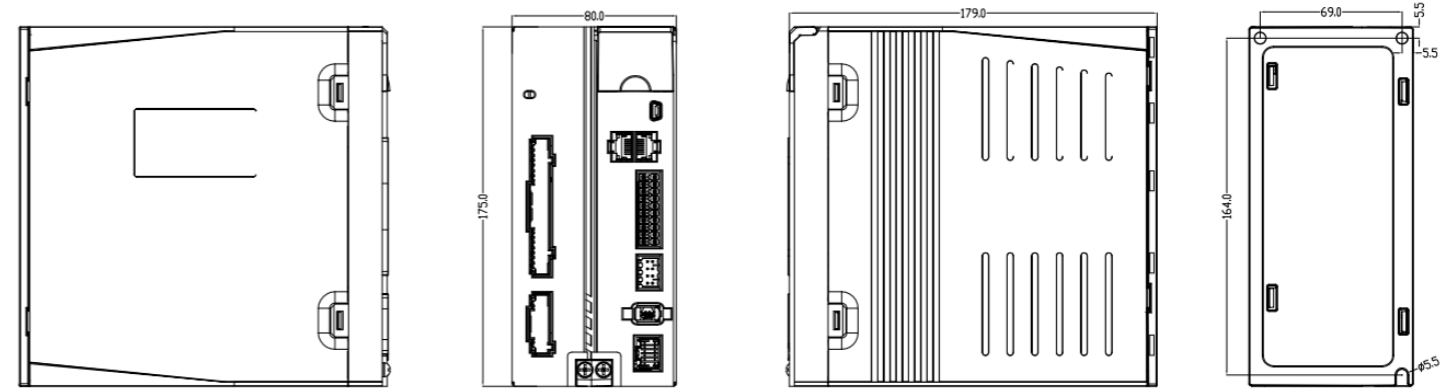

• 380V 4.4kW/5.5kW/7.5kW

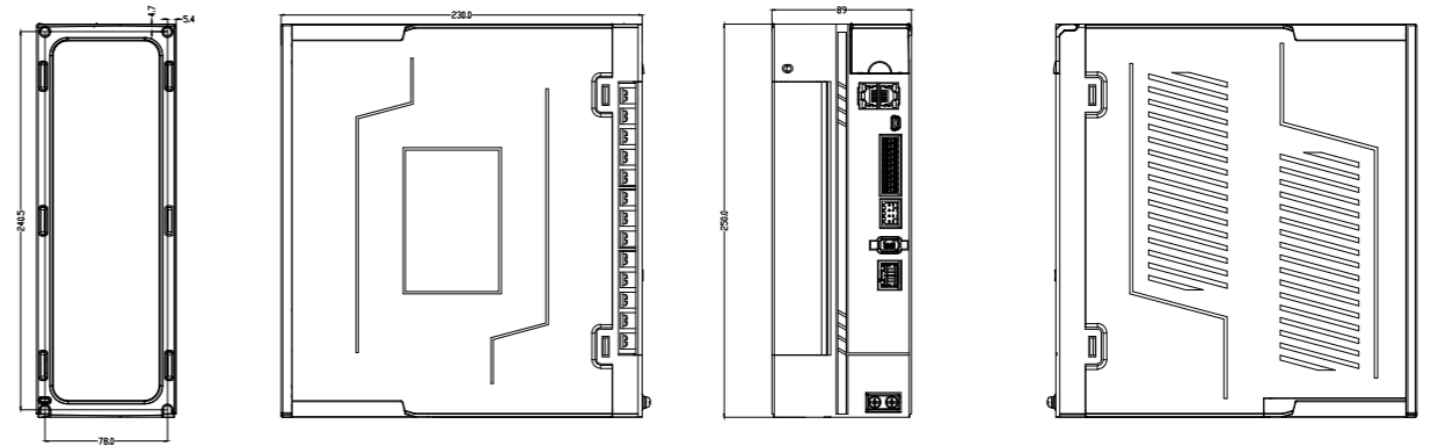

System Wirings

• 220V 400W-2kW

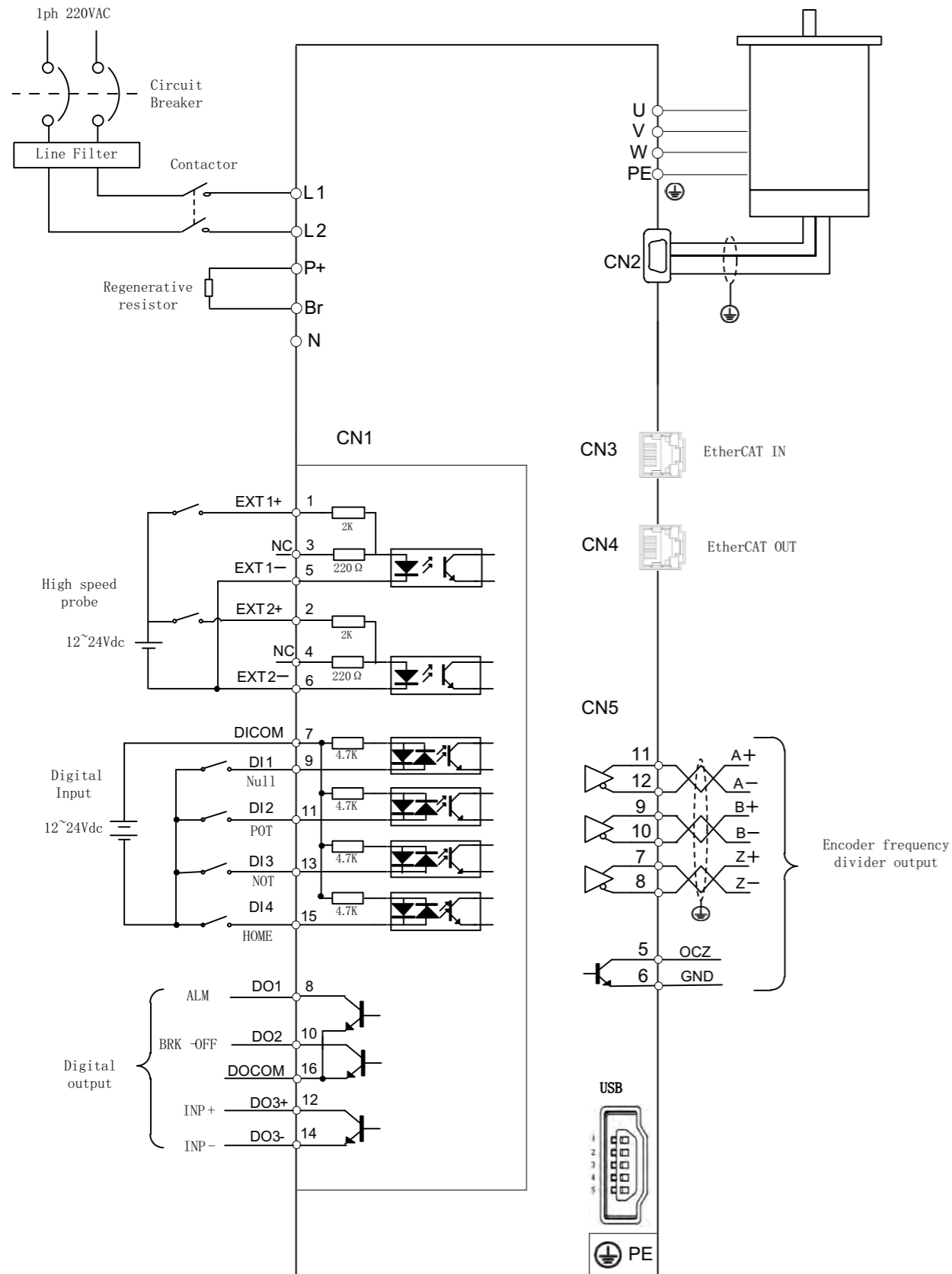

System Wirings

• 380V 750W-7.5kW

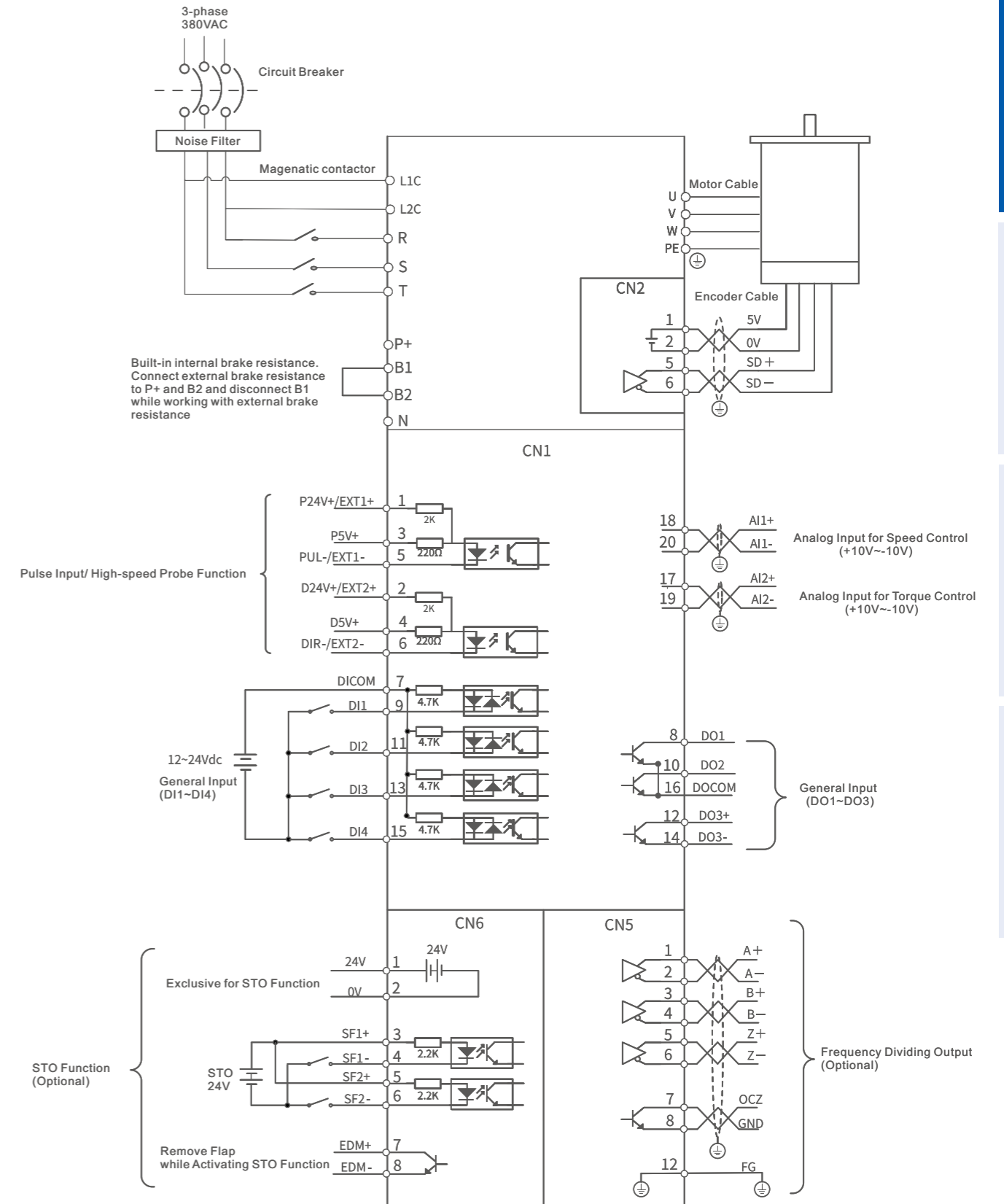

AC Servo Drives

EL7-PN Series (Coming soon)

- 1ph 220VAC(400W-2kW)
- 3ph 380VAC(750W-7.5kW)
- Safe Torque Off (IEC61508 SIL3)
- Frequency response up to 3.2kHz



- Conform to PROFI drive, AC1/AC3/AC4 supported
- Supports RT/IRT
- Auto-tuning
- Vibration suppression
- Feedforward gain
- 6 DI, 3 DO



Products Models

- 1-phase/3-phase 200-240VAC, 50/60Hz

Model	Power rating (W)	Rated current (Arms)	Peak current (Arms)	Dimensions(mm)
EL7-PN400F	400	3.5	9.5	55*175*179
EL7-PN750F	750	5.5	16.6	55*175*179
EL7-PN1000F	1000	7.0	18.7	55*175*179
EL7-PN1500F	1500	9.5	31.1	80*175*179
EL7-PN2000F	2000	12	36	80*175*179

- 3-phase 380-440VAC, 50/60Hz

Model	Power rating (W)	Rated current (Arms)	Peak current (Arms)	Dimensions(mm)
EL7-PN750FT	750	2.7	8.6	55*175*179
EL7-PN1000FT	1000	3.5	10.6	55*175*179
EL7-PN1500FT	1500	5.4	14.9	55*175*179
EL7-PN2000FT	2000	8.4	24.8	80*175*179
EL7-PN3000FT	3000	11.9	11.9	80*175*179
EL7-PN4400FT	4400	16.5	16.5	90*250*230
EL7-PN5500FT	5500	20.8	20.8	90*250*230
EL7-PN7500FT	7500	25.7	25.7	90*250*230

Applications

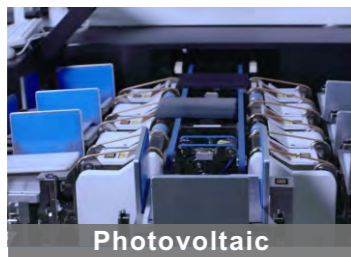

AC Servo Drives

EL8 – EC Series 220VAC Models



- Power rating: 400W-2000W
- 1ph/3ph 220VAC input
- 1-click tuning
- Full closed loop control
- Automatically matched with Leadshine servo motors
- 23-bit optical/magnetic motor encoder

EL8-EC Series AC Servo Drives are our latest high end EtherCAT servo drives which are packed with a whole lot more new hardware and software features. We added STO SIL3, Analogue I/Os, holding brake port and EL8 series now supports a 2nd external encoder as well with our full closed loop control.

Combined with abundant of software features such as Zero Tracking Control, 42 points position comparison, Gantry synchronization and much more, we are able to bring EL8-EC series AC Servo Drive to many different kinds of industrial applications that demand high performance.



EtherCAT

EL8 Series EL8-EC EtherCAT Servo Drives

Position/Velocity/Torque Mode

- EtherCAT – CiA402 CoE
- 8 DI, 3 DO, 2 AI and 2 AO – User configurable
- Built-in regenerative resistor and holding brake port
- External position sensor for full closed loop control

Upgraded position command following capability

- Zero tracking control (ZTC) aimed to increase position following precision and realize zero position deviation during acceleration/ deceleration especially in a multi-axial movement.



Easy servo tuning

- One-click tuning functions added to EL8 to realize a quick and uncomplicated tuning work.
- Step-by-step guide to this tuning is built into our whole new Motion Studio 2.2.

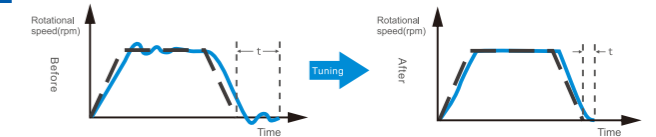

Full closed loop control

- Supports a 2nd external position sensor with position feedback.
- Eliminates position deviation due to mechanical gap with obvious improvement on precision.

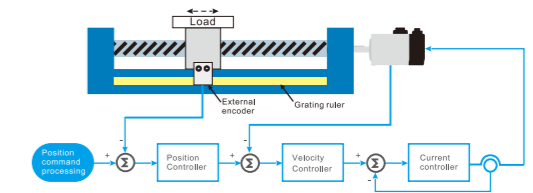

Multiple servo axes control management

- Servo parameters of multiple axes can be read/write through Motion Studio using EtherCAT protocol.

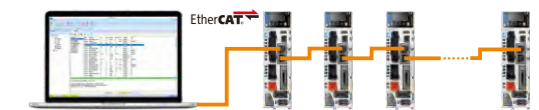

Part Numbers

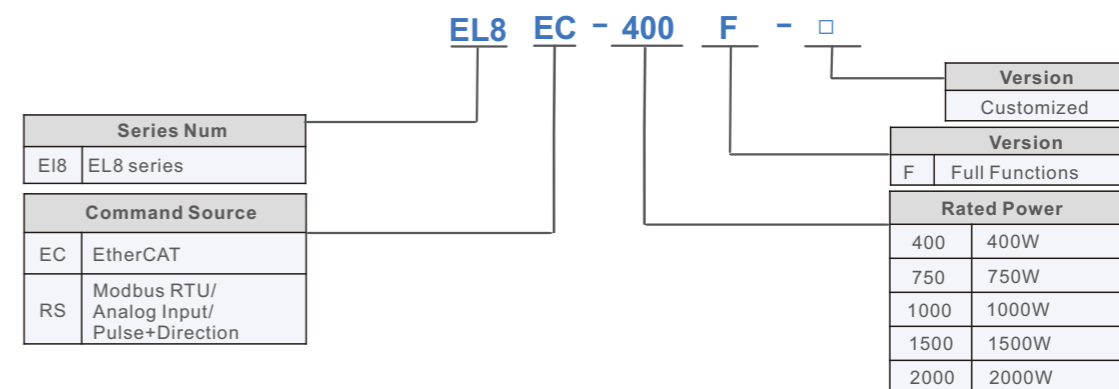

Specifications

EL8-EC Series	EL8-EC400F	EL8-EC750F	EL8-EC1000F	EL8-EC1500F	EL8-EC2000F
Power Rating (W)	400W	750W	1000W	1500W	2000W
Rated Current (A)	2.8	5.5	7.0	9.5	12
Peak Current (A)	9.3	16.9	21.2	31.1	36
Control Circuit Power Supply	1-Ph AC 200V– 240VAC, -10% - +10%, 50/60Hz				
Main Power Supply	1-Ph/3-Ph AC 200V– 240VAC, -10% - +10%, 50/60Hz				
Regenerative Resistor	Whole series comes with internal regenerative resistor and supports external regenerative resistor				
Resistance(Ω)	100	50		50	
Power Rating(W)	50	75		80	
Cooling Method	Air-cooled	Fan-cooled			
Dimension H*L*W(mm)	150*150*43	150*160*55		80*168*183	
Ports	Descriptions				
USB Type-C	Modify or read driver parameters without connecting to main power supply				
Crossover Frequency Output	Supports phase A/B/Z differential crossover frequency output Supports phase Z open collector crossover frequency output				
Analog Input	2 analog inputs (AI1/AI2), -10V~+10V, Max. voltage: ±12V				
Analog Output	2 analog outputs (AO1/AO2), -10V~+10V				
Digital Input	8 Digital Inputs (Supports common anode or cathode connection) 1. Clear Alarm (A-CLR) 2. Positive limit switch (POT) 3. Negative limit switch (NOT) 4. Homing switch (HOME-SWITCH) 5. Emergency stop (E-Stop)				
Digital Output	3 Digital outputs (3 double-ended, DO1~DO3) 1. Alarm (ALM) 2. Servo ready (SRDY) 3. External brake off (BRK-OFF) 4. Positioning completed (INP) 5. Velocity at arrival (AT-SPEED) 6. Torque limiting command (TLC) 7. Zero speed position (ZSP) 8. Velocity coincidence (V-COIN) 9. Position command (P-CMD) 10. Velocity limit (V-LIMIT) 11. Velocity command (V-CMD) 12. Servo enabled (SRV-ST) 13. Homing done (HOME-OK) 14. Position comparison (CMP-OUT)				
Safe Torque Off (STO)	IEC61508 SIL3				
Encoder #2	Available				
Holding Brake	Internal holding brake. External relay not needed				
Communication Port	EtherCAT Protocol, RJ45 port				
Control Mode					
Position	Profile Position Mode (PP)				
	Cyclic Synchronous Position Mode (CSP)				
	Homing Mode (HM)				
Velocity	Profile Velocity Mode (PV)				
	Cyclic Synchronous Velocity Mode (CSV)				
Torque	Profile Torque Mode (PT)				
	Cyclic Synchronous Torque Mode (CST)				

Control Features	
Drive Mode	IGBT SVPWM sinusoidal wave drive
Frequency response	Up to 3.5kHz
Feedback Method	Encoder: RS485 Protocol
Easy Servo Tuning	One-click tuning, Single parameter tuning
Notch Filter	Mechanical resonance suppression. Supports up to 3 filters, 50Hz~4000Hz
Vibration Suppression	Mechanical End Vibration Suppression
DI/DO settings	User configurable Digital Inputs and Digital Outputs
DI/DO settings	Overcurrent. Overvoltage. Undervoltage. Overheat. Overload. Overtravel. Single-Phasing. Regenerative resistor error. Position deviation error. Encoder feedback error. Excessive braking rate. EEPROM error.
Front Panel	5 push buttons, 8-segments display, 5 warning LEDs
Software	Driver tuning through Motion Studio Ver. 2.2.x. Parameters tuning in current loop, position loop, velocity loop; Modify I/O signal and motor parameters; Variables(velocity, position deviation, etc.) monitoring using step diagrams.
Communication	USB Type-C: Modbus USB2.0 (No need to connect driver to power supply)
	EtherCAT: RJ45. Communication up to 128 axes to a host
Dynamic Brake	Internal dynamic brake
Position Comparison	42 position comparison outputs
Suitable Load Inertia	30 times smaller than motor inertia

Dimensions

• 400W

Unit: mm

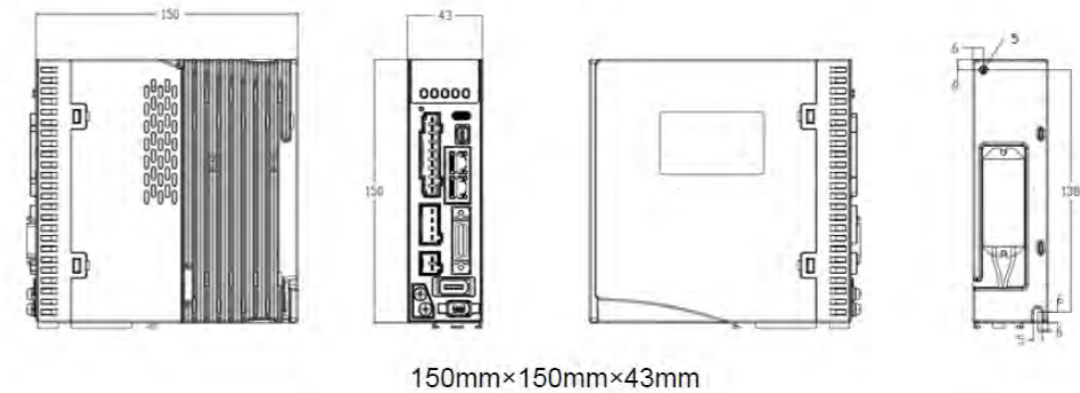

• 750W / 1000W

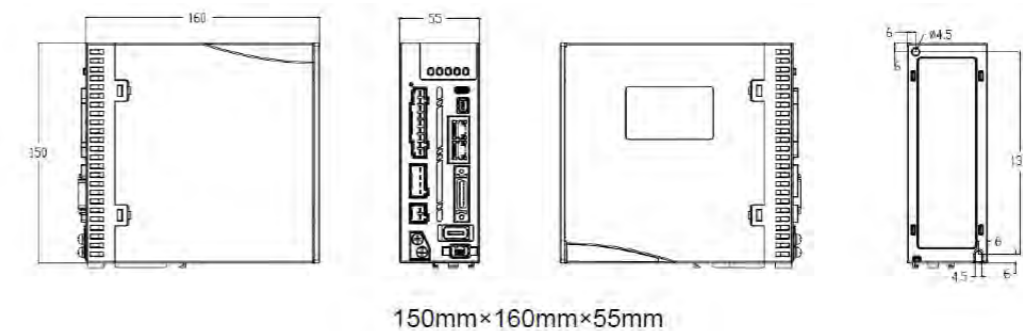

Servo Drive Pin Assignments

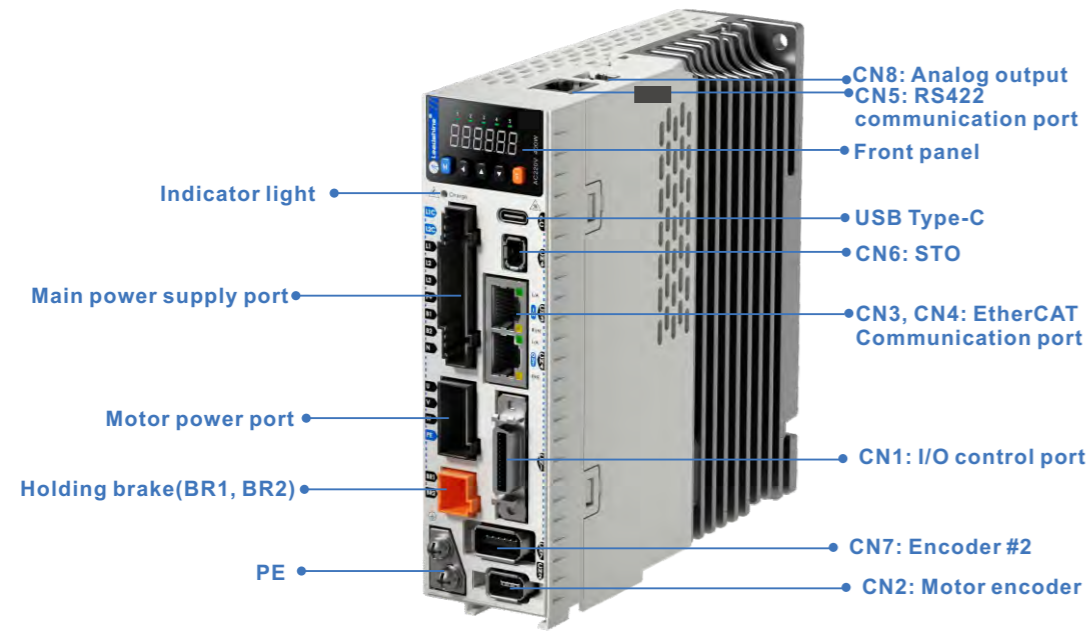

Motion Studio - GUI Software

- By connecting servo drive to PC, parameters setting and data monitoring can all be done on Motion Studio
- Parameters setting and tuning comes with easy to follow step-by-step guides
- Easy to use features such mechanical properties analysis, inertia ratio identification, etc to help users getting the most out of the servo drive
- Whole new Scope tool is highly configurable, accurate and historical waveforms records can be saved and viewed anytime
- All EtherCAT features are consolidated into Motion Studio for more convenient settings.

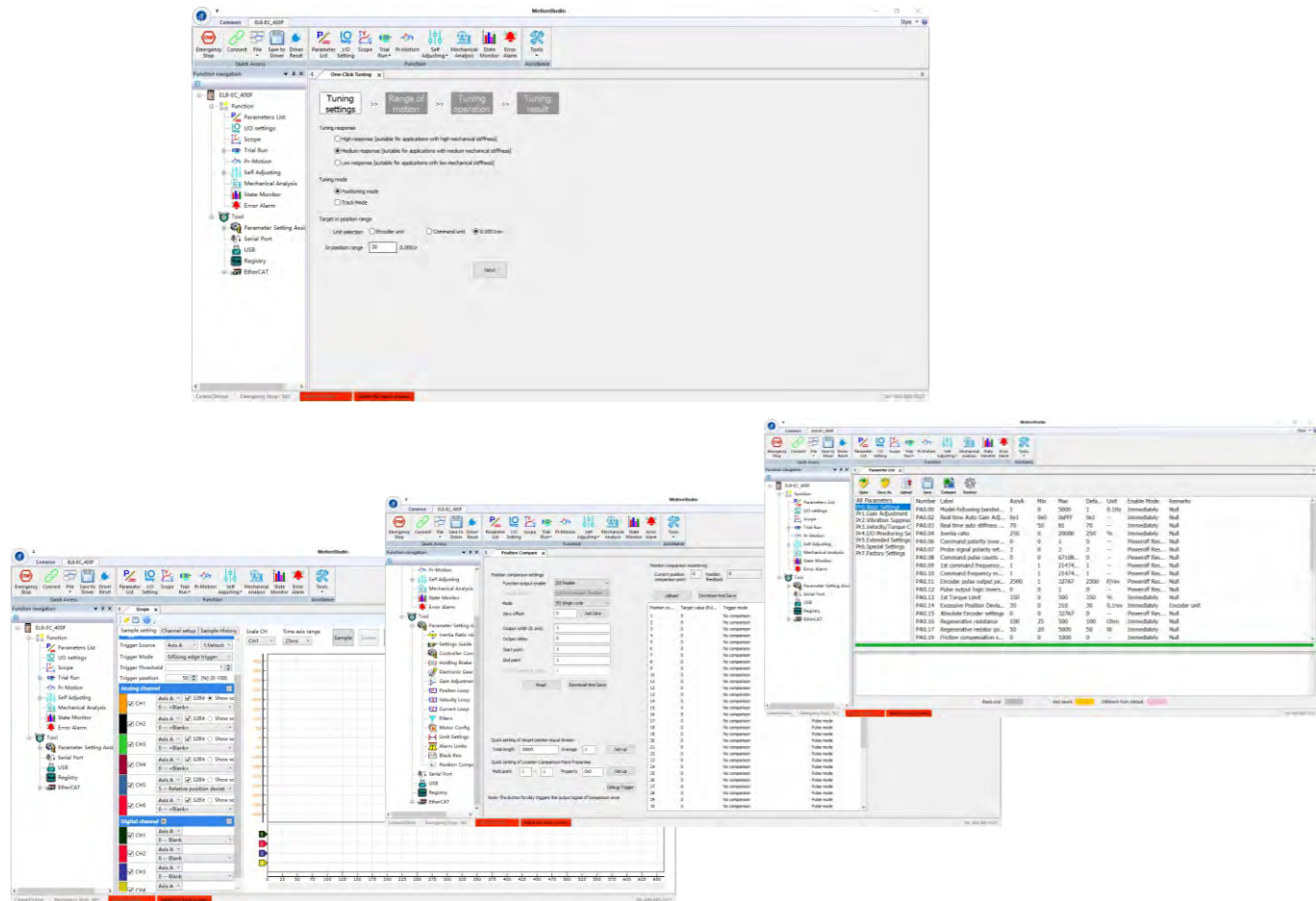

System Wirings

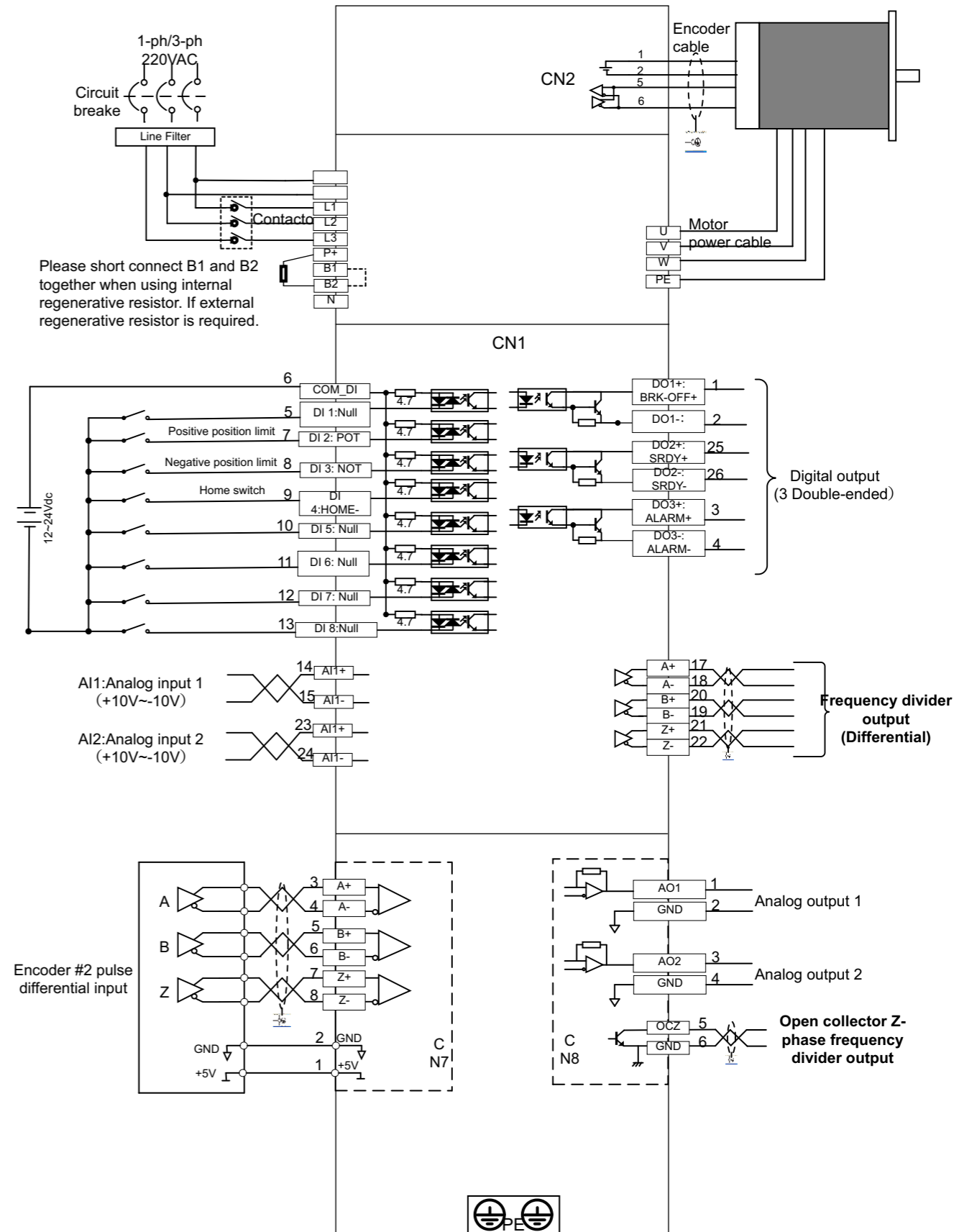

AC Servo Drives

EL8 – RS Series 220VAC Models



- Power rating: 400W-2000W
- 1ph/3ph 220VAC input
- 1-click tuning
- Full closed loop control
- Automatically matched with Leadshine servo motors
- 23-bit optical/magnetic motor encoder

EL8-RS Series AC Servo Drives are our latest high end servo drives which combine analogue control, Modbus RTU protocol (RS485) and pulse + direction control into one. We added STO SIL3, more I/Os (both digital and analogue), holding brake port. EL8 series now supports a 2nd external encoder as well with our full closed loop control.

Combined with abundant of software features such as Zero Tracking Control, 42 points position comparison, Gantry synchronization and much more, we are able to bring EL8-RS series AC Servo Drive to many different kinds of industrial applications that demand high performance.



EL8 Series EL8-RS Servo Drives

Position/Velocity/Torque Mode/Hybrid Mode

- Modbus RTU(RS485), Pulse + Direction, Analogue
- 10 DI, 6DO, 3AI and 2AO – User configurable
- PR mode with 16 highly configurable paths

Upgraded position command following capability

- Zero tracking control (ZTC) aimed to increase position following precision and realize zero position deviation during acceleration/ deceleration especially in a multi-axial movement.



Easy servo tuning

- One-click tuning functions added to EL8 to realize a quick and uncomplicated tuning work.
- Step-by-step guide to this tuning is built into our whole new Motion Studio 2.2.

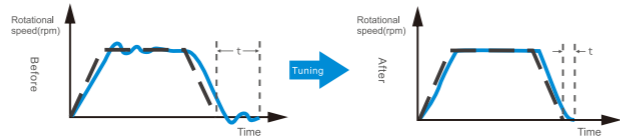

Full closed loop control

- Supports a 2nd external position sensor with position feedback.
- Eliminates position deviation due to mechanical gap with obvious improvement on precision.

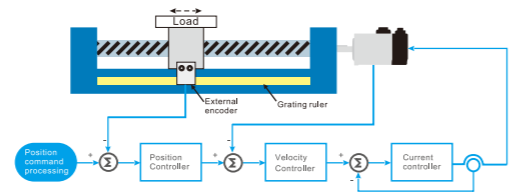

Black Box

- Can be set up to record data when specific error occurs and data recorded will be saved to aid in error solving.



Part Numbers

EL8 RS - 400 F - □

Series Num		Version	
EL8	EL8 series	Customized	
Command Source		Version	
EC	EtherCAT	F	Full Functions
RS	Modbus RTU/ Analog Input/ Pulse+Direction	Rated Power	
		400	400W
		750	750W
		1000	1000W
		1500	1500W
		2000	2000W

Specifications

EL8-RS Series	EL8-RS400	EL8-RS750	EL8-RS1000	EL8-RS1500	EL8-RS2000
Power Rating (W)	400W	750W	1000W	1500W	2000W
Rated Current (A)	2.8	5.5	7.0	9.5	12
Peak Current (A)	9.3	16.9	21.2	31.1	36
Control Circuit Power Supply	1-Ph AC 200V– 240VAC, -10% - +10%, 50/60Hz				
Main Power Supply	1-Ph/3-Ph AC 200V– 240VAC, -10% - +10%, 50/60Hz				
Regenerative Resistor	Whole series comes with internal regenerative resistor and supports external regenerative resistor				
Resistance(Ω)	100	50		50	
Power Rating(W)	50	75		80	
Cooling Method	Air-cooled	Fan-cooled			
Dimension H*L*W(mm)	150*150*43	150*160*55		80*168*183	
Ports	Descriptions				
USB Type-C	Modify or read driver parameters without connecting to main power supply				
Crossover Frequency Output	Supports phase A/B/Z differential crossover frequency output Supports phase Z open collector crossover frequency output				
Low-speed Pulse Input	5V differential signal, 0-500kHz 24V differential signal, 0-200kHz				
High-speed Pulse Input	5V differential signal, 0-4MHz				
Analog Input	3 analog inputs(AI1/AI2/AI3),-10V~+10V, Max. voltage: ±12V				
Analog Output	2 analog outputs(AO1/AO2), -10V~+10V				
Digital Input	10 Digital Inputs (Supports common anode or cathode connection) <ol style="list-style-type: none"> 1. Clear Alarm (A-CLR) 2. Positive limit switch (POT) 3. Negative limit switch (NOT) 4. Gain switching (GAIN) 5. Emergency stop (E-Stop) 6. Deviation counter clearing (CL) 7. Control mode switching (C-MODE) 8. Torque limit switching (TL-SEL) 9. Vibration suppression 1(VS-SEL1) 10. Vibration suppression 2(VS-SEL2) 11. Command prohibition(INH) 12. Internal command velocity 1(INTSPD1) 13. Internal command velocity 2(INTSPD2) 14. Internal command velocity 3(INTSPD3) 15. Crossover frequency input(DIV1) 16. Zero speed clamp(ZEROSPD) 17. Velocity sign(VC-SIGN) 18. Torque sign(TC-SIGN) Under PR mode <ol style="list-style-type: none"> 1. Path trigger (CTRG) 2. Home switch (HOME) 3. Emergency stop trigger(STP) 4. Path 0-3 (ADD0-ADD3) 5. Positive JOG (PJOG) 6. Negative JOG(NJOG) 7. Positive limit switch(PL) 8. Negative limit switch(NL) 9. Origin(ORG) 				
Digital Output	6 digital outputs (2 single ended, 4 double-ended) <ol style="list-style-type: none"> 1. Alarm (ALM) 2. Servo ready (SRDY) 3. External brake off (BRK-OFF) 4. Positioning completed (INP1) 5. Velocity at arrival (AT-SPEED) 6. Zero speed position (ZSP) 7. Velocity coincidence (V-COIN) 8. Position command (P-CMD) 9. Velocity limit (V-LIMIT) 10. Velocity command (V-CMD) 11. Servo enabled (SRV-ST) 12. Positive limit switch(POT-OUT) 13. Negative limit switch (NOT-OUT) Under PR mode <ol style="list-style-type: none"> 1. Command completed (CMD-OK) 2. Path completed (PR-OK) 3. Homing done (HOME-OK) 				

Safe Torque Off (STO)	Available for all EL8-RS series servo drives	
Encoder #2		
Holding Brake	Internal holding brake output. External relay not needed	
Communication Port	Modbus RS485 protocol, RJ45 port	
Control Mode		
Communication Port	<ol style="list-style-type: none"> External pulse train position control JOG control Closed loop position control Velocity control Torque control Hybrid control: Position-Torque/Position-Velocity/Velocity-Torque 	
Position	Pulse frequency	500kHz/4MHz(5V differential input);200kHz(24V single-ended input)
	Electronic gear ratio	(1-8388608)/(1-8388608)
	Torque Limit	<i>Please refer to parameter settings</i>
Control Features		
Drive Mode	IGBT SVPWM sinusoidal wave drive	
Frequency response	Up to 3.5kHz	
Feedback Method	Encoder: RS485 Protocol	
Standardized Parameters	Quick tuning of servo driver parameters can be achieved through PC tuning tools.	
Easy-to-use	One-click tuning, Single parameter tuning, Black box, Zero tracking control	
Notch Filter	Mechanical resonance suppression. Supports up to 3 filters,50Hz~4000Hz	
Vibration suppression	End vibration suppression	
DI/DO Settings	Digital inputs and outputs can be set accordingly	
Alarm	Overcurrent. Overvoltage. Undervoltage. Overheat. Overload. Overtravel. Single-Phasing. Regenerative resistor error. Position deviation error. Encoder feedback error. Excessive braking rate. EEPROM error	
Front Panel	5 push buttons, 8-segments display, 5 warning LEDs	
Software	Driver tuning through Motion Studio Ver. 2.2.x. Parameters tuning in current loop, position loop, velocity loop; Modify I/O signal and motor parameters; Variables(velocity, position deviation, etc.) monitoring using step diagrams	
Communication	USB Type-C	Modbus USB2.0 (No need to connect driver to power supply)
	Modbus	RJ45. Communication up to 32 axes to a host
Dynamic Brake	Internal dynamic brake	
Position Comparison	42 position comparison outputs	
Suitable Load Inertia	30 times smaller than motor inertia	

Dimensions

• 400W

Unit: mm

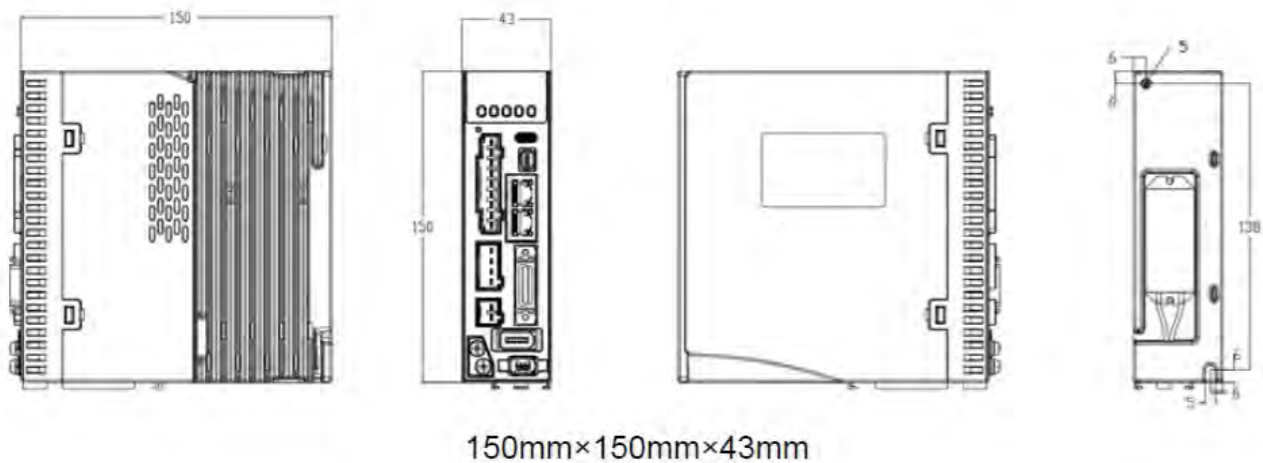

• 750W / 1000W

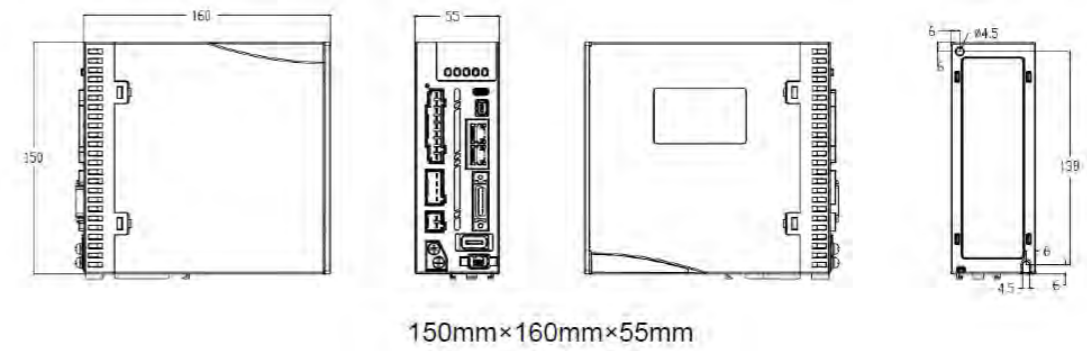

Servo Drive Pin Assignments

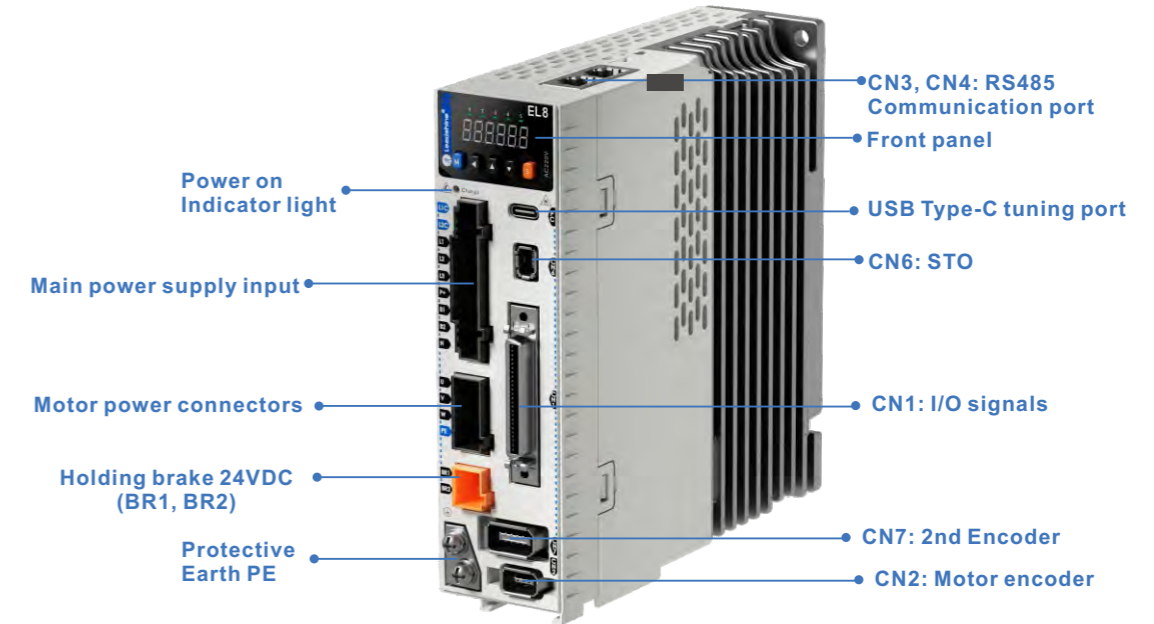

Motion Studio - GUI Software

- By connecting servo drive to PC, parameters setting and data monitoring can all be done on Motion Studio
- Parameters setting and tuning comes with easy to follow step-by-step guides
- Easy to use features such mechanical properties analysis, inertia ratio identification, etc to help users getting the most out of the servo drive
- Whole new Scope tool is highly configurable, accurate and historical waveforms records can be saved and viewed anytime
- All servo drive features are consolidated into Motion Studio for more convenient settings.

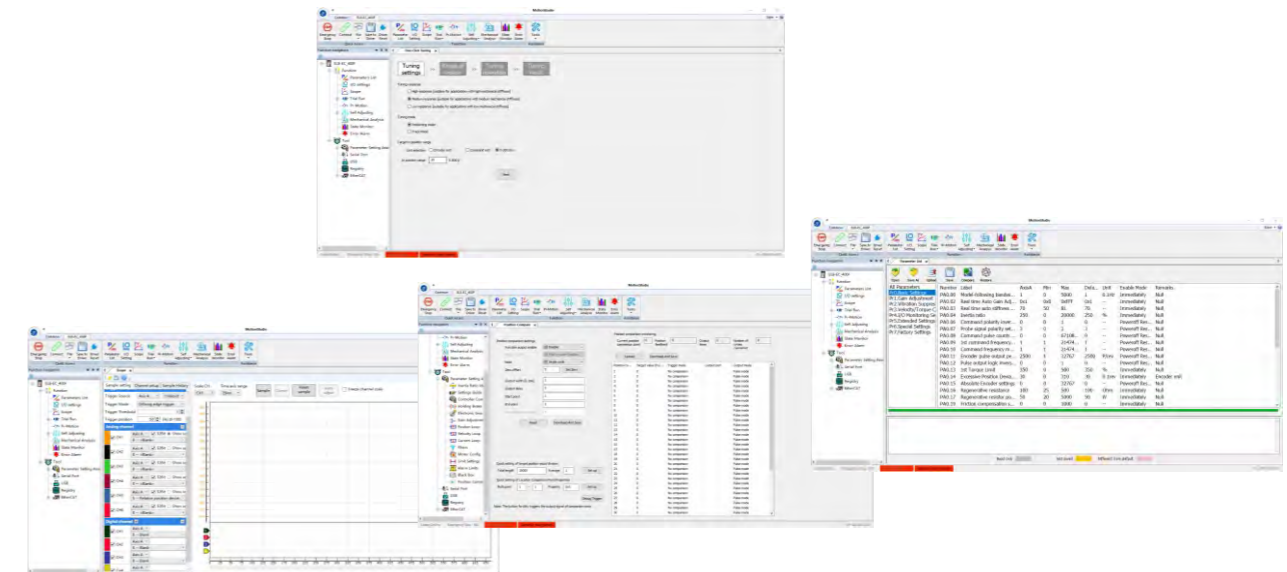

System Wirings

Position+Full Closed Loop Control

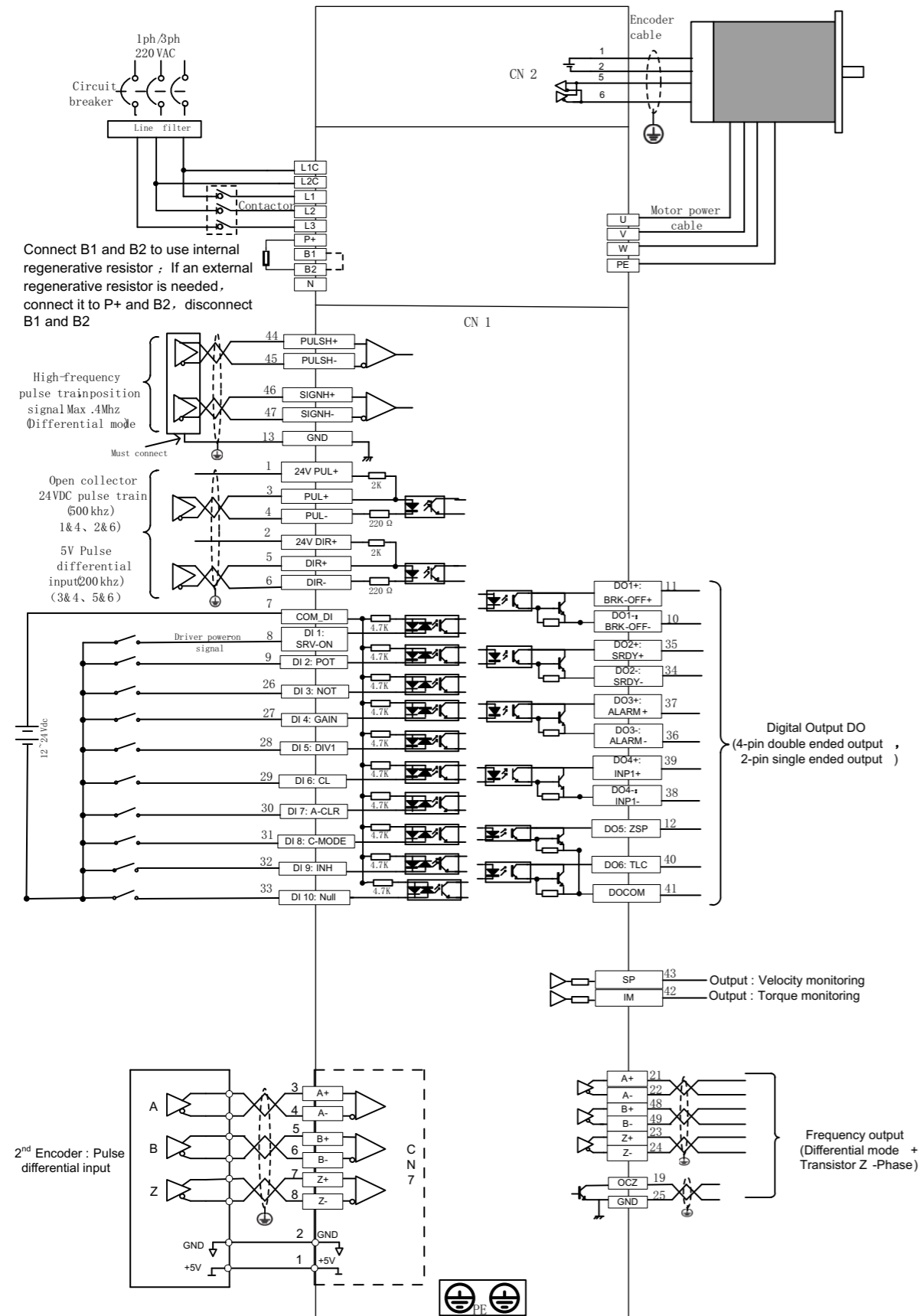

Torque Control

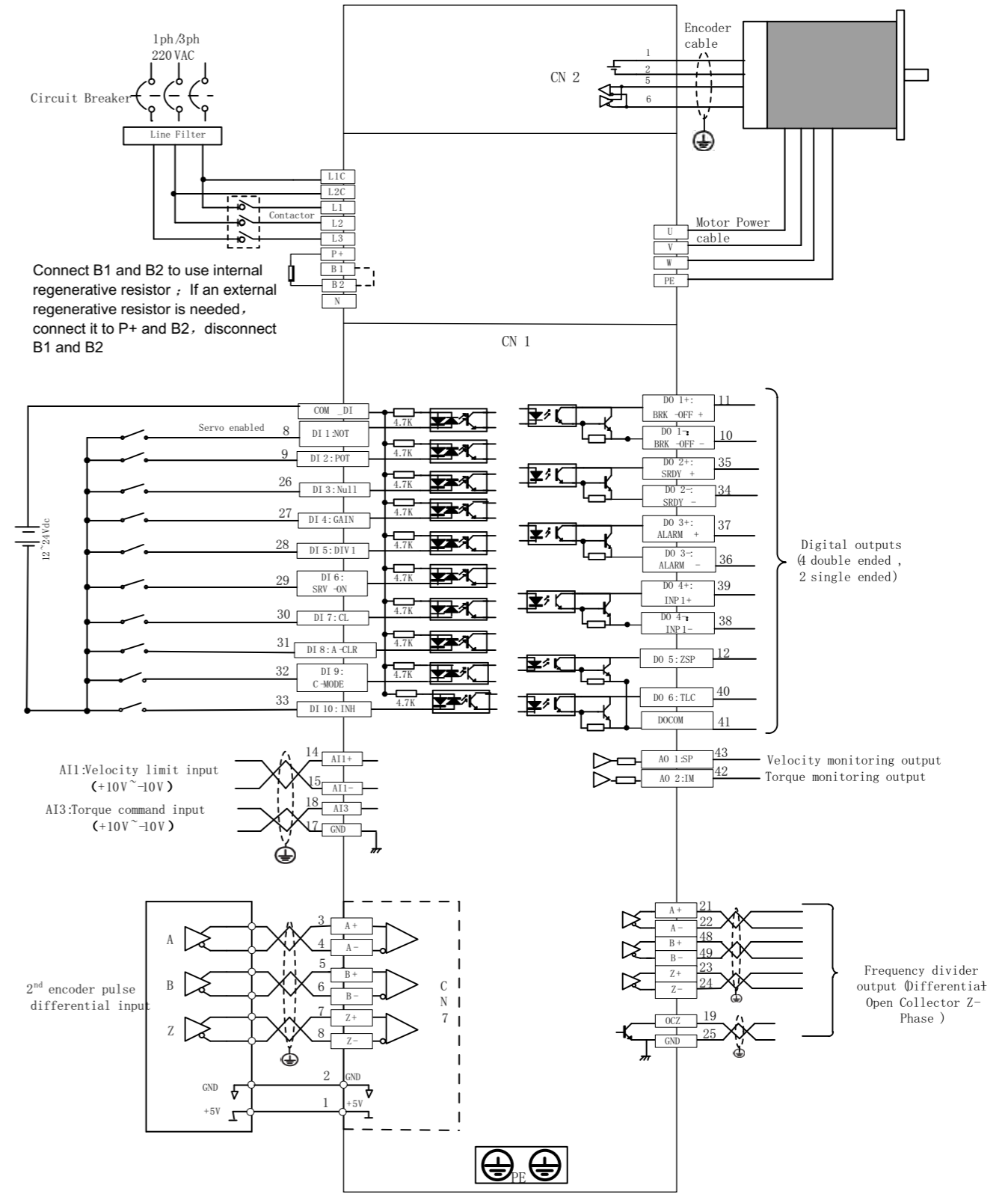

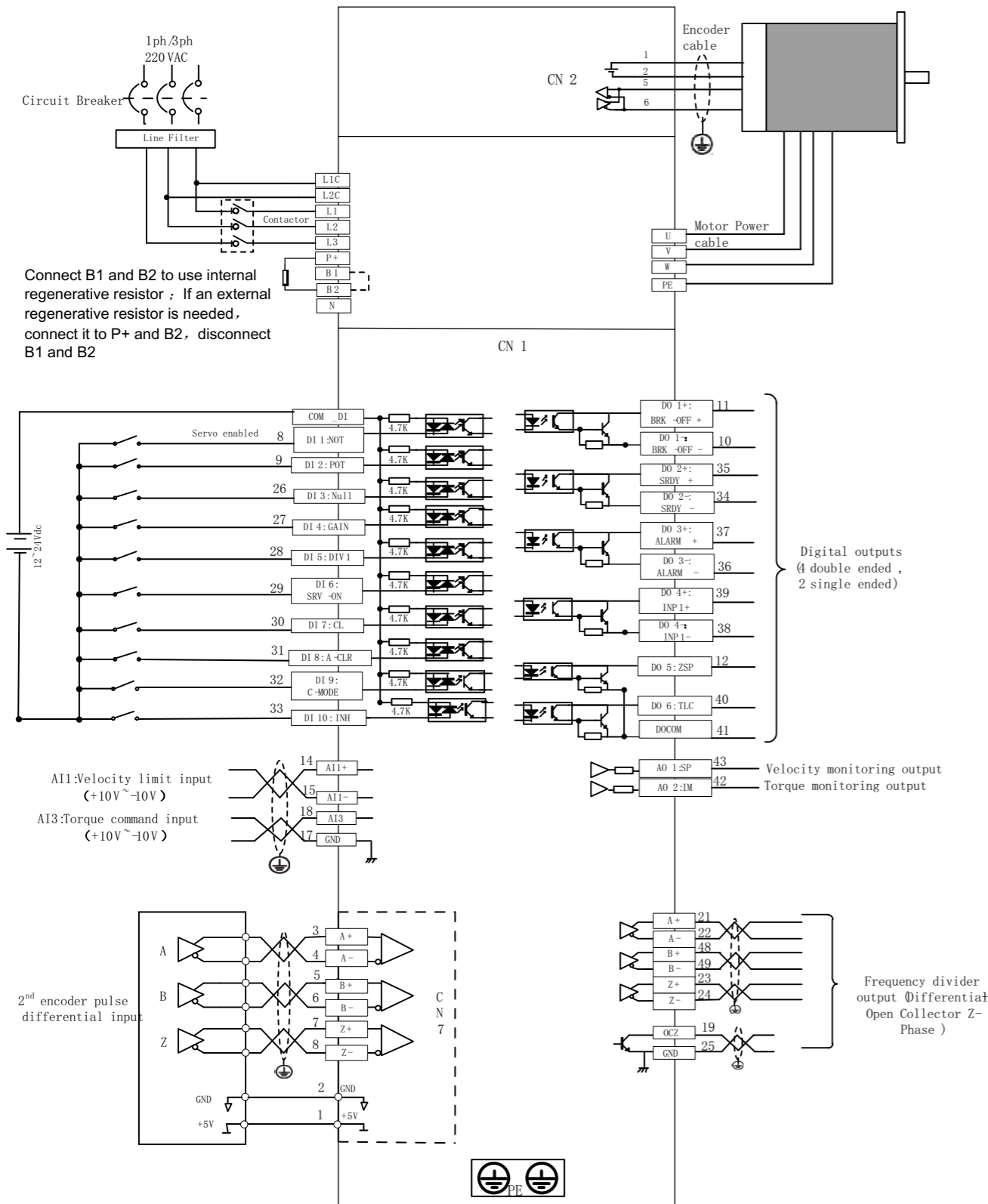

AC Servo Motors

ELM1/ELM2 Series

- Power rating: 50W - 7.5kW
- Voltage: 220VAC/380VAC
- Feedback: 23-bit absolute encoder
- Frame size: 40mm, 60mm, 80mm, 100mm, 130mm, 180mm

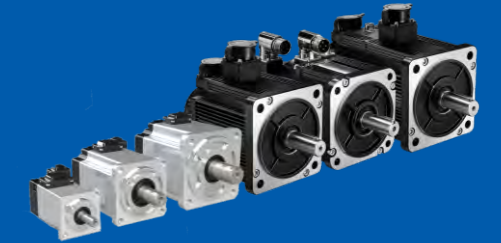

Part Numbers

ELM1 H - 0400 M A 60 F T - H

Series Num	
ELM1	ELM1 Series servo motor
ELM2	ELM2 Series servo motor

Inertia Ratio	
L	Low
M	Medium
H	High

Rated Output Power	
0050	50W
0100	100W
0200	200W
0400	400W
0750	750W
0850	850W
1000	1000W
1300	1300W
1500	1500W
1800	1800W
2000	2000W
2900	2900W
3000	3000W
4000	4000W
4400	4400W
5000	5000W
5500	5500W
7000	7000W
7500	7500W

Encoder Type	
L	23-bit optical multi-turn
M	23-bit magnetic multi-turn

Rated Speed	
A	3000rpm
B	2500rpm
C	2000rpm
D	1500rpm

Connect Type	
Blank	Direct connector
H	Aviation connector - H
HD	Aviation connector - HD

Voltage	
Blank	220VAC
T	380VAC

Motor Type	
E	With brake, oil seal
F	No brake, oil seal

Frame Size	
40	40mm
60	60mm
80	80mm
100	100mm
130	130mm
180	180mm

Servo motors with 220VAC (ELM1)

ELM1 Model	ELM1H-0050MA40E	ELM1H-0100MA40E	ELM1H-0200MA60E	ELM1H-0400MA60E	ELM1H-0750MA80E	ELM1H-1000MA80E	
	ELM1H-0050MA40F	ELM1H-0100MA40F	ELM1H-0200MA60F	ELM1H-0400MA60F	ELM1H-0750MA80F	ELM1H-1000MA80F	
Frame Size[mm]	40		60		80		
Rated Power[W]	50	100	200	400	750	1000	
Rated Voltage[VAC]	220						
Rated Torque[Nm]	0.16	0.32	0.64	1.27	2.39	3.18	
Peak Torque[Nm]	0.48	0.95	1.92	3.81	7.17	9.54	
Rated Current[A rms]	0.93	0.92	1.5	2.1	4.1	5.7	
Peak Current[A rms]	2.88	2.85	4.5	6.5	13.4	17.7	
Rated Speed[r/min]	3000	3000	3000	3000	3000	3000	
Peak Speed[r/min]	5000	5000	5000	5000	5000	5000	
Inertia [kgm ² *10 ⁻⁴]	Without Brake	0.036	0.062	0.28	0.56	1.5	2.0
	With Brake	0.046	0.072	0.3	0.58	1.65	2.15
Weight (kg)	Without Brake	0.28	0.38	1.0	1.3	2.12	2.8
	With Brake	0.44	0.54	1.3	1.55	2.7	3.4
Permissible Load to Shaft (N)	Radial	78	78	245	245	392	392
	Axial	54	54	74	74	147	147
Encoder Type	23bit magnetic multi-turn						
Plug Type	Direct connector						
Matching Cable	Motor Cable	With brake: CABLE-RZSH*M*-114-TS				No brake: CABLE-RZH*M*-114-TS	
	Encoder Cable	Absolute: CABLE-BMAH*M*-124-TS				Incremental: CABLE-BMH*M*-114-TS	
Matching Drive	Priority	EL7-**400* EL8-**400*		EL7-**750* EL8-**750*		EL7-**1000* EL8-**1000*	
	Optional	EL6-**400*		EL6-**750*		EL6-**1000*	

• Dimensions

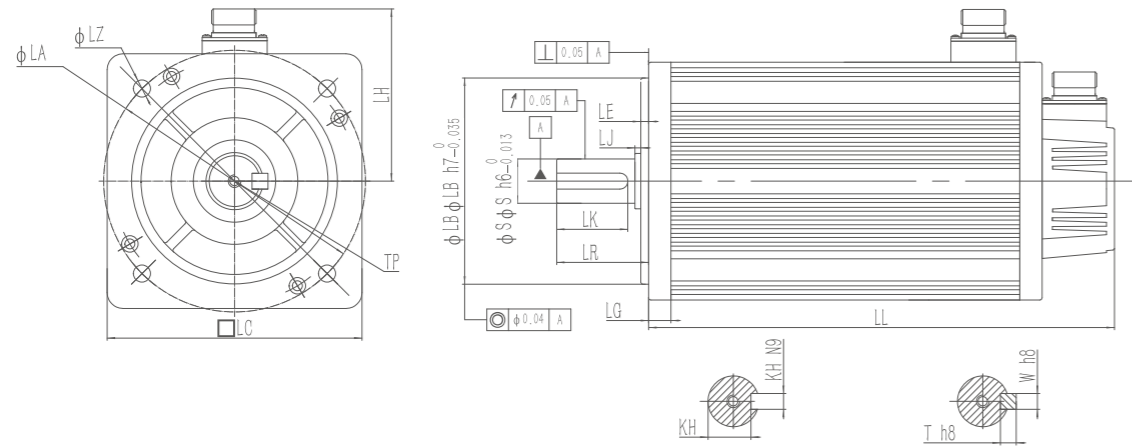

Motor Model	LL	LC	LR	LA	LZ	LH	LG	LE	LJ	S	LB	TP	LK	KH	kW	W	T
ELM1H-0050MA40F	56.7	40	25	46	4.5	35MAX	5	3	3	8	30	M3X8	14	6.2	3	3	3
ELM1H-0050MA40E	84	40	25	46	4.5	35MAX	5	3	3	8	30	M3X8	14	6.2	3	3	3
ELM1H-0100MA40F	67.7	40	25	46	4.5	35MAX	5	3	3	8	30	M3X8	14	6.2	3	3	3
ELM1H-0100MA40E	95	40	25	46	4.5	35MAX	5	3	3	8	30	M3X8	14	6.2	3	3	3
ELM1H-0200MA60F	71.6	60	30	70	5.5	45MAX	6.6	3	3	14	50	M5X12	22.5	11	5	5	5
ELM1H-0200MA60E	100.9	60	30	70	5.5	45MAX	6.6	3	3	14	50	M5X12	22.5	11	5	5	5
ELM1H-0400MA60F	88.8	60	30	70	5.5	45MAX	6.6	3	3	14	50	M5X12	22.5	11	5	5	5
ELM1H-0400MA60E	118.1	60	30	70	5.5	45MAX	6.6	3	3	14	50	M5X12	22.5	11	5	5	5
ELM1H-0750MA80F	90.9	80	35	90	6.5	55MAX	8.1	3	3	19	70	M5X15	25	15.5	6	6	6
ELM1H-0750MA80E	121.9	80	35	90	6.5	55MAX	8.1	3	3	19	70	M5X15	25	15.5	6	6	6
ELM1H-1000MA80F	103.9	80	35	90	6.5	55MAX	8.1	3	3	19	70	M5X15	25	15.5	6	6	6
ELM1H-1000MA80E	134.9	80	35	90	6.5	55MAX	8.1	3	3	19	70	M5X15	25	15.5	6	6	6

• Speed - Torque characteristics

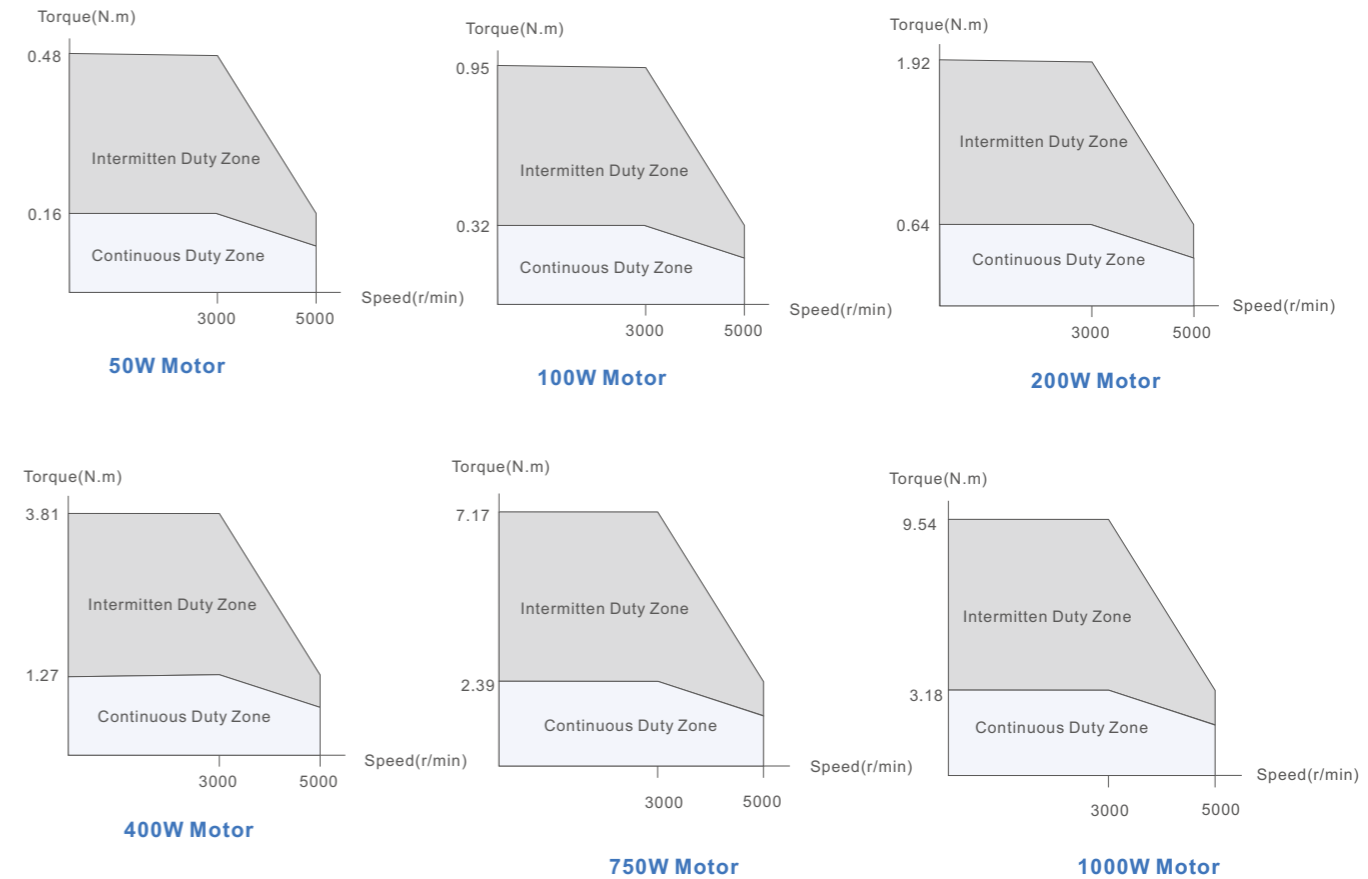

Servo motors with 220VAC (ELM2)

ELM2 Model	ELM2H-0050LA40E	ELM2H-0100LA40E	ELM2H-0200LA60E	ELM2H-0400LA60E	ELM2H-0750LA80E	ELM2H-1000LA80E
	ELM2H-0050LA40F	ELM2H-0100LA40F	ELM2H-0200LA60F	ELM2H-0400LA60F	ELM2H-0750LA80F	ELM2H-1000LA80F
Frame Size[mm]	40		60		80	
Rated Power[W]	50	100	200	400	750	1000
Rated Voltage[VAC]	220					
Rated Torque[Nm]	0.16	0.32	0.64	1.27	2.39	3.18
Peak Torque[Nm]	0.48	0.95	1.92	3.81	7.17	9.54
Rated Current[Arms]	0.93	0.92	1.5	2.1	4.1	5.7
Peak Current[Arms]	2.88	2.85	4.5	6.5	13.4	17.7
Rated Speed[r/min]	3000	3000	3000	3000	3000	3000
Peak Speed[r/min]	5000	5000	5000	5000	5000	5000
Inertia [kgm ² *10 ⁻⁴]	Without Brake	0.036	0.062	0.28	0.56	1.5
	With Brake	0.046	0.072	0.3	0.58	1.65
Weight (kg)	Without Brake	0.28	0.38	1.0	1.3	2.12
	With Brake	0.44	0.54	1.3	1.55	2.7
Permissible Load to Shaft (N)	Radial	78	78	245	245	392
	Axial	54	54	74	74	147
Encoder Type	23bit optical multi-turn					
Plug Type	Direct connector					
Motor Cable	With brake: CABLE-RZSH*M*-114-TS No brake: CABLE-RZH*M*-114-TS					
Encoder Cable	Absolute: CABLE-BMAH*M*-124-TS Incremental: CABLE-BMH*M*-114-TS					
Matching Drive	Priority	EL7-**400* EL8-**400*		EL7-**750* EL8-**750*	EL7-**1000* EL8-**1000*	
	Optional	EL6-**400*		EL6-**750*	EL6-**1000*	

• Dimensions

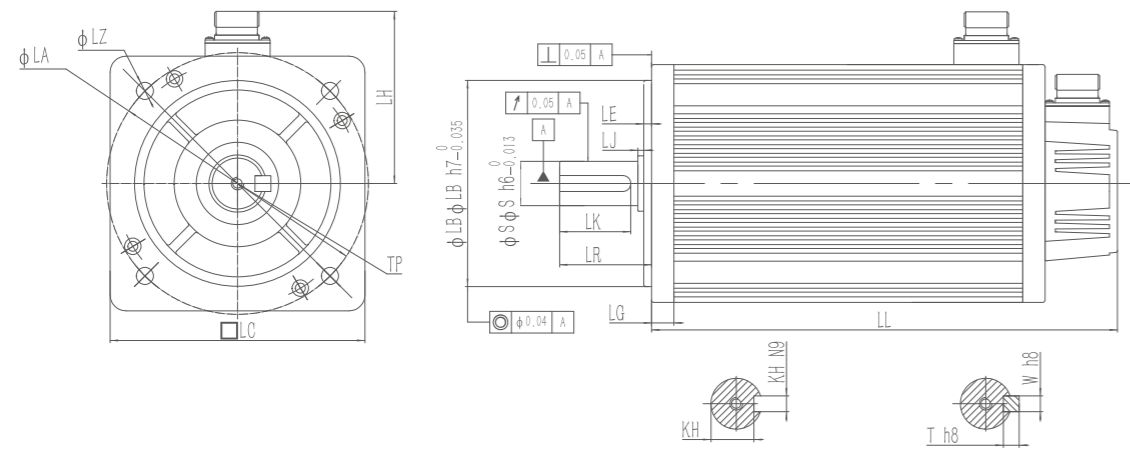

Motor Model	LL	LC	LR	LA	LZ	LH	LG	LE	LJ	S	LB	TP	LK	KH	kW	W	T
ELM2H-0050LA40F	56.7	40	25	46	4.5	35MAX	5	3	3	8	30	M3X8	14	6.2	3	3	3
ELM2H-0050LA40E	84	40	25	46	4.5	35MAX	5	3	3	8	30	M3X8	14	6.2	3	3	3
ELM2H-0100LA40F	67.7	40	25	46	4.5	35MAX	5	3	3	8	30	M3X8	14	6.2	3	3	3
ELM2H-0100LA40E	95	40	25	46	4.5	35MAX	5	3	3	8	30	M3X8	14	6.2	3	3	3
ELM2H-0200LA60F	71.6	60	30	70	5.5	45MAX	6.6	3	3	14	50	M5X12	22.5	11	5	5	5
ELM2H-0200LA60E	100.9	60	30	70	5.5	45MAX	6.6	3	3	14	50	M5X12	22.5	11	5	5	5
ELM2H-0400LA60F	88.8	60	30	70	5.5	45MAX	6.6	3	3	14	50	M5X12	22.5	11	5	5	5
ELM2H-0400LA60E	118.1	60	30	70	5.5	45MAX	6.6	3	3	14	50	M5X12	22.5	11	5	5	5
ELM2H-0750LA80F	90.9	80	35	90	6.5	55MAX	8.1	3	3	19	70	M5X15	25	15.5	6	6	6
ELM2H-0750LA80E	121.9	80	35	90	6.5	55MAX	8.1	3	3	19	70	M5X15	25	15.5	6	6	6
ELM2H-1000LA80F	103.9	80	35	90	6.5	55MAX	8.1	3	3	19	70	M5X15	25	15.5	6	6	6
ELM2H-1000LA80E	134.9	80	35	90	6.5	55MAX	8.1	3	3	19	70	M5X15	25	15.5	6	6	6

• Speed - Torque characteristics

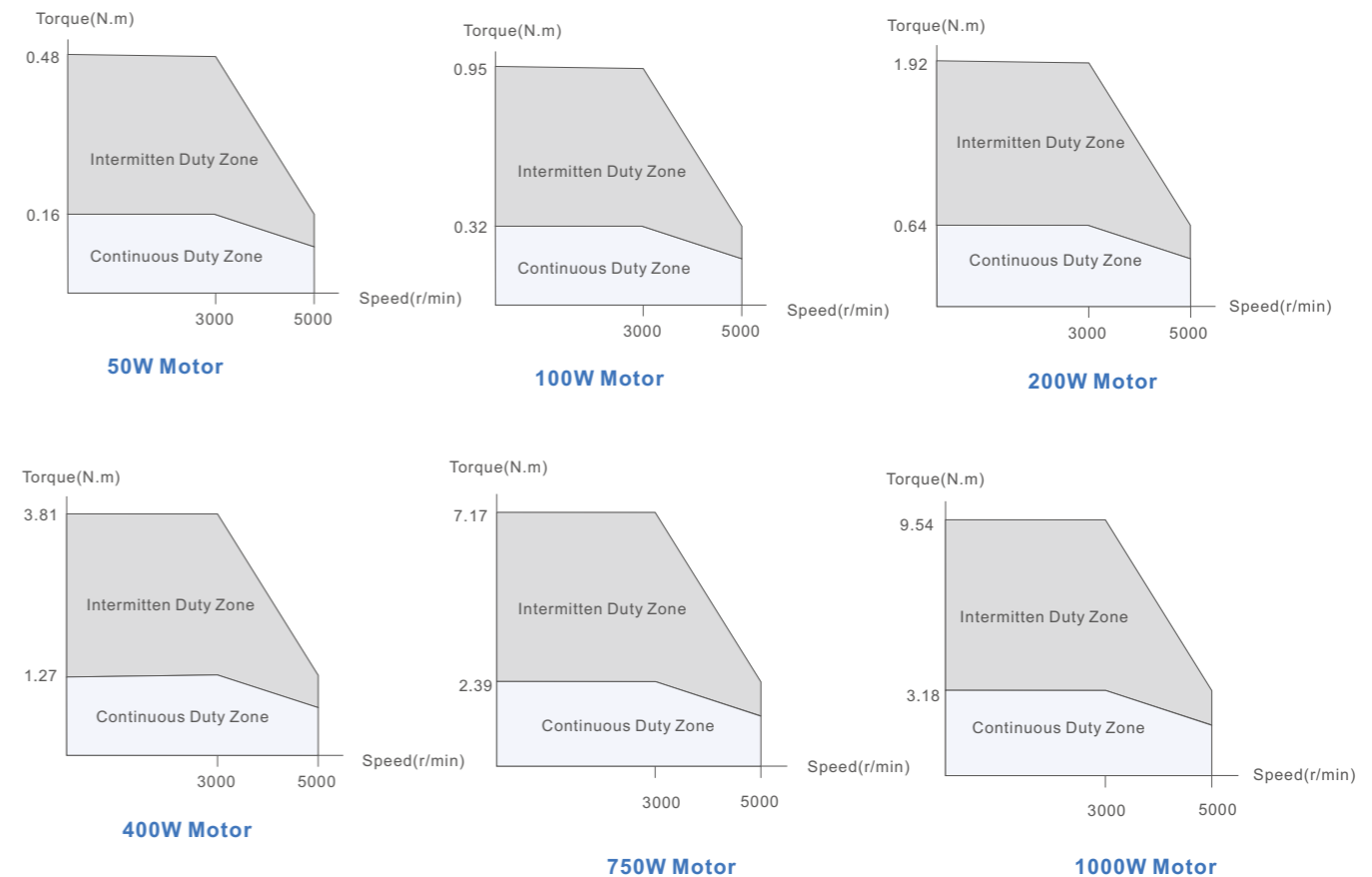

ELM2 Model	ELM2H-0850LD130E-HD	ELM2H-1300LD130E-HD	ELM2H-1800LD130E-HD	
	ELM2H-0850LD130F-HD	ELM2H-1300LD130F-HD	ELM2H-1800LD130F-HD	
Frame Size[mm]	130	130	130	
Rated Power[W]	850	1300	1800	
Rated Voltage[VAC]	220			
Rated Torque[Nm]	5.4	8.4	11.5	
Peak Torque[Nm]	16.2	25.2	34.5	
Rated Current[Arms]	6.5	9.5	9.0	
Peak Current[Arms]	19.5	28.5	28.4	
Rated Speed[r/min]	1500	1500	1500	
Peak Speed[r/min]	3000	3000	2000	
Inertia [kgm ² *10 ⁻⁴]	Without Brake	13.88	20.59	23.69
	With Brake	15.78	22.26	25.36
Weight (kg)	Without Brake	5.6	7.5	8.1
	With Brake	6.9	8.8	9.4
Permissible Load to Shaft (N)	Radial	490	490	490
	Axial	196	196	196
Encoder Type	23bit optical multi-turn			
Plug Type	Aviation connector-HD			
Matching Cable	Motor Cable	CABLE-RZ*M*-HD(V2.0)		
	Encoder Cable	Absolute: CABLE-7BMA*M*-HD(V3.0) Incremental: CABLE-7BM*M*-HD(V3.0)		
	Brake Cable	CABLE-SC*M*-HD(V3.0)		
Matching Drive	Priority	EL7-**1000* EL8-**1000*	EL7-**1500*	EL7-**2000*
	Optional	EL6-**1000*	EL8-**1500*	EL8-**2000*

• Dimensions

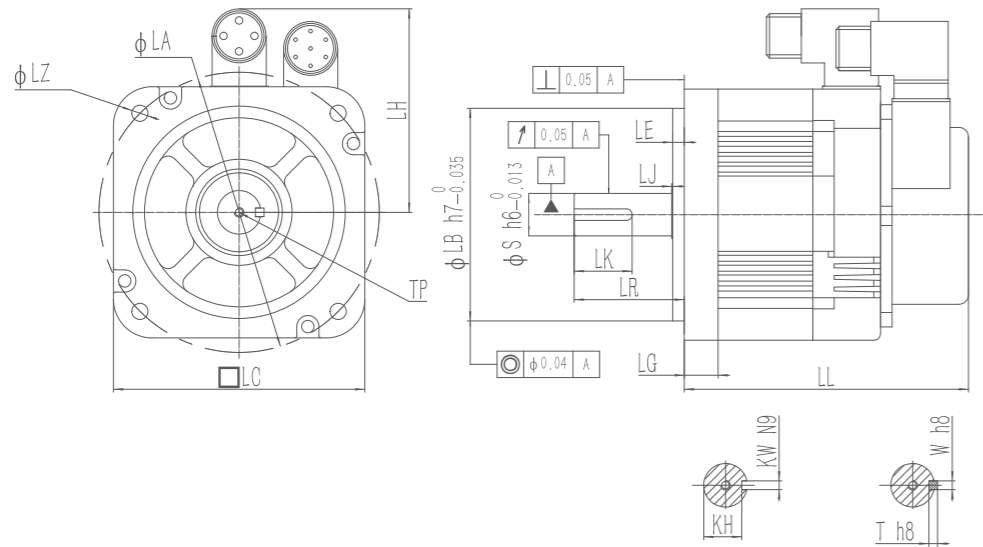

Motor Model	LL	LC	LR	LA	LZ	LH	LG	LE	LJ	S	LB	TP	LK	KH	KW	W	T
ELM2H-0850LD130F-HD	147	130	57	145	8.5	106	17.5	6	0.5	19	110	M5X12	30	16	5	5	5
ELM2H-0850LD130E-HD	172	130	57	145	8.5	106	17.5	6	0.5	19	110	M5X12	30	16	5	5	5
ELM2H-1300LD130F-HD	168	130	57	145	8.5	106	17.5	6	0.5	22	110	M5X12	30	18.5	6	6	6
ELM2H-1300LD130E-HD	192	130	57	145	8.5	106	17.5	6	0.5	22	110	M5X12	30	18.5	6	6	6
ELM2H-1800LD130F-HD	195	130	57	145	8.5	106	17.5	6	0.5	24	110	M5X15	30	19	8	8	8
ELM2H-1800LD130E-HD	219	130	57	145	8.5	106	17.5	6	0.5	24	110	M5X15	30	19	8	8	8

• Speed - Torque characteristics

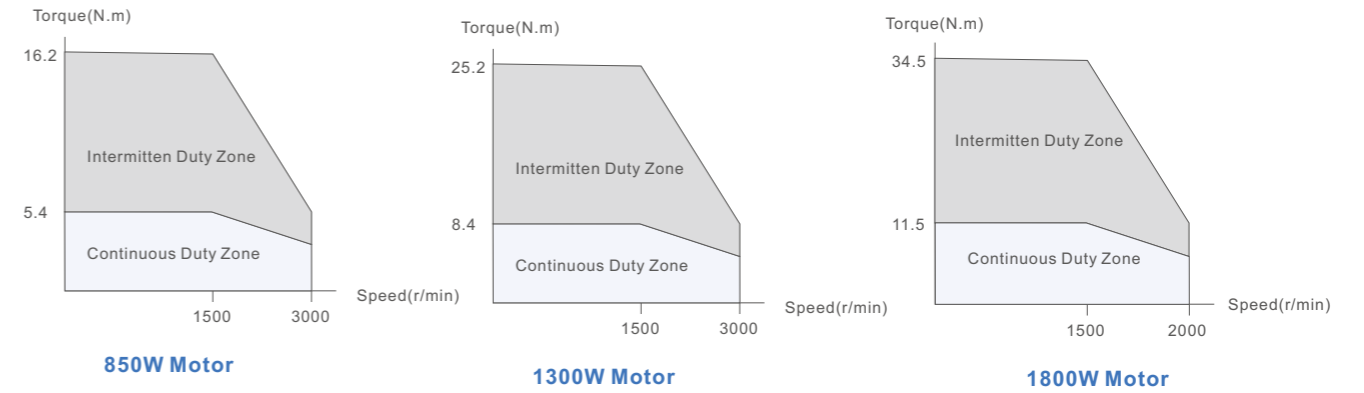

850W Motor

1300W Motor

1800W Motor

ELM2 Model	ELM2M-1000LB130E-H	ELM2M-1500LB130E-H	ELM2M-2000LB130E-H	
	ELM2M-1000LB130F-H	ELM2M-1500LB130F-H	ELM2M-2000LB130F-H	
Frame Size[mm]	130	130	130	
Rated Power[W]	1000	1500	2000	
Rated Voltage[VAC]	220			
Rated Torque[Nm]	4	6	7.7	
Peak Torque[Nm]	12	18	22	
Rated Current[Arms]	4	6	7.5	
Peak Current[Arms]	12	18	22	
Rated Speed[r/min]	2500	2500	2500	
Peak Speed[r/min]	2600	2600	2800	
Inertia [kgm ² *10 ⁻⁴]	Without Brake	8.5	12.6	15.3
	With Brake	8.95	12.6	16.8
Weight (kg)	Without Brake	6.2	7.4	8.3
	With Brake	8.3	9.5	11
Permissible Load to Shaft (N)	Radial	490	490	490
	Axial	196	196	196
Encoder Type	23bit optical multi-turn			
Plug Type	Aviation connector-H			
Matching Cable	Motor Cable	CABLE-RZ*M*-H(V2.0)		
	Encoder Cable	Absolute: CABLE-7BM*M*-HZ(V3.0) Incremental: CABLE-7BMA*M*-HZ(V3.0)		
	Brake Cable	CABLE-SC*M*-H(V3.0)		
Matching Drive	Priority	EL7-**1000* EL8-**1000*	EL7-**1500* EL8-**1500*	EL7-**2000* EL8-**2000*
	Optional	EL6-**1000*	-	-

• Dimensions

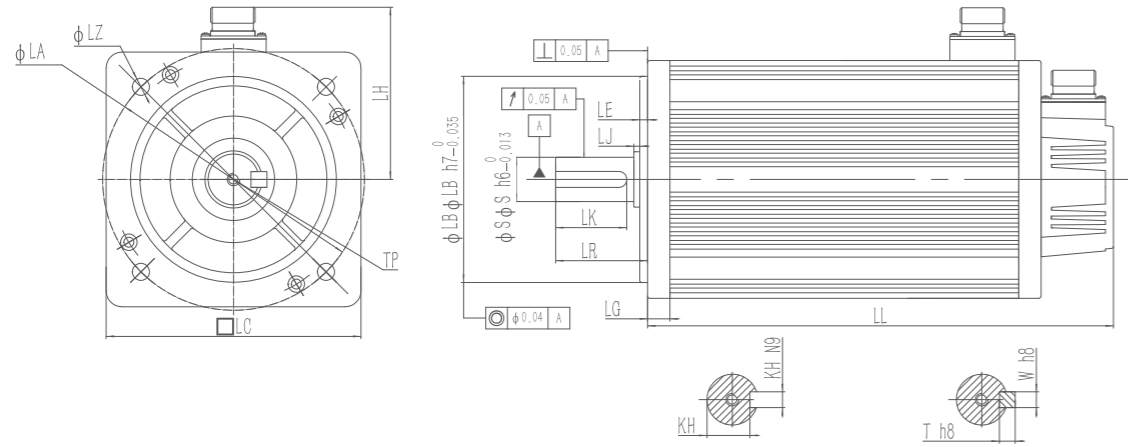

Motor Model	LL	LC	LR	LA	LZ	LH	LG	LE	LJ	S	LB	TP	LK	KH	kW	W	T
ELM2M-1000LB130F-H	166	131	57	145	9	111	14	5	2	22	110	M6X20	40	18.5	6	6	6
ELM2M-1000LB130E-H	223	131	57	145	9	111	14	5	2	22	110	M6X20	40	18.5	6	6	6
ELM2M-1500LB130F-H	179	131	57	145	9	111	14	5	2	22	110	M6X20	40	18.5	6	6	6
ELM2M-1500LB130E-H	236	131	57	145	9	111	14	5	2	22	110	M6X20	40	18.5	6	6	6
ELM2M-2000LB130F-H	192	131	57	145	9	111	14	5	2	22	110	M6X20	40	18.5	6	6	6
ELM2M-2000LB130E-H	270	131	57	145	9	111	14	5	2	22	110	M6X20	40	18.5	6	6	6

• Speed - Torque characteristics

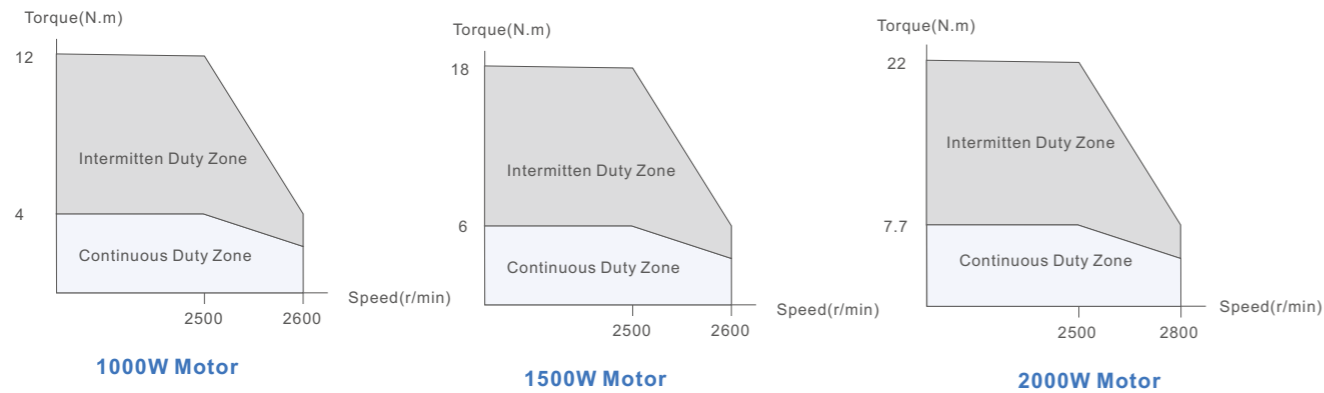

Servo motors with 380VAC (ELM2)

ELM2 Model	ELM2H-0750LA80FT	ELM2H-1000LA80FT	ELM2L-1000LA100FT-H	ELM2L-1500LA100FT-H
	ELM2H-0750LA80ET	ELM2H-1000LA80ET	ELM2L-1000LA100ET-H	ELM2L-1500LA100ET-H
Frame Size[mm]	80		100	
Rated Power[W]	750	1000	1000	1500
Rated Voltage[VAC]	380			
Rated Torque[Nm]	3.39	3.18	3.2	4.9
Peak Torque[Nm]	7.17	9.54	9.6	14.7
Rated Current[Arms]	2.7	4	3.9	5.1
Peak Current[Arms]	8.8	12.4	11.7	14.4
Rated Speed[r/min]	1500	1500	3000	3000
Peak Speed[r/min]	3000	3000	6000	5000
Inertia [kgm ² *10 ⁻⁴]	Without Brake	1.5	2	2.43
	With Brake	1.65	2.15	2.63
Weight (kg)	Without Brake	2.12	2.8	4.6
	With Brake	2.7	3.4	5.9
Permissible Load to Shaft (N)	Radial	392	392	490
	Axial	147	147	98
Encoder Type	23bit optical multi-turn			
Plug Type	Direct connector		Aviation connector-H	
Matching Cable	Motor Cable	With brake: CABLE-RZSH*M*-114-TS No brake: CABLE-RZH*M*-114-TS		CABLE-RZ*M*-H(V2.0)
	Brake Cable			CABLE-SC*M*-H(V3.0)
	Encoder Cable	Absolute: CABLE-BMAH*M*-124-TS Incremental: CABLE-BMH*M*-114-TS		Absolute: CABLE-7BM*M*-HZ(V3.0) Incremental: CABLE-7BMA*M*-HZ(V3.0)
Matching Drive	Priority	EL7-**750*T	EL7-**1000*T	EL7-**1000*T EL7-**1500*T

• Dimensions

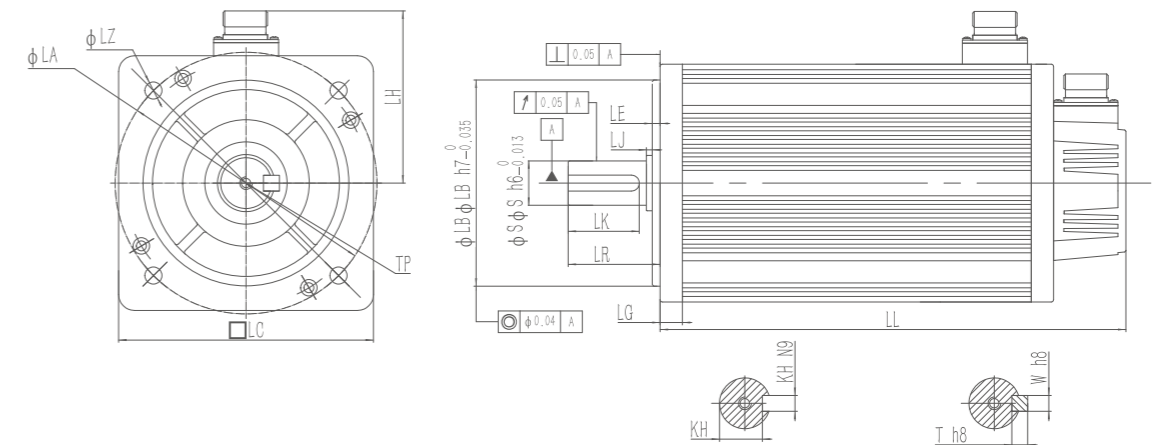

Motor Model	LL	LC	LR	LZ	LH	LG	LE	LJ	S	LB	TP	LK	KH	kW	W	T
ELM2H-0750LA80FT	90.9	80	35	6.5	55	8.1	3	3	19	70	M5X15	25	15.5	6	6	6
ELM2H-0750LA80ET	121.9	80	35	6.5	55	8.1	3	3	19	70	M5X15	25	15.5	6	6	6
ELM2H-1000LA80FT	103.9	80	35	6.5	55	8.1	3	3	19	70	M5X15	25	15.5	6	6	6
ELM2H-1000LA80ET	134.9	80	35	6.5	55	8.1	3	3	19	70	M5X15	25	15.5	6	6	6
ELM2L-1000LA100FT-H	154	100	45	9	111	12	5	2.5	24	95	M8X16	36	20	8	8	7
ELM2L-1000LA100ET-H	194	100	45	9	111	12	5	2.5	24	95	M8X16	36	20	8	8	7
ELM2L-1500LA100FT-H	178	100	45	9	111	12	5	2.5	24	95	M8X16	36	20	8	8	7
ELM2L-1500LA100ET-H	218	100	45	9	111	12	5	2.5	24	95	M8X16	36	20	8	8	7

• Speed - Torque characteristics

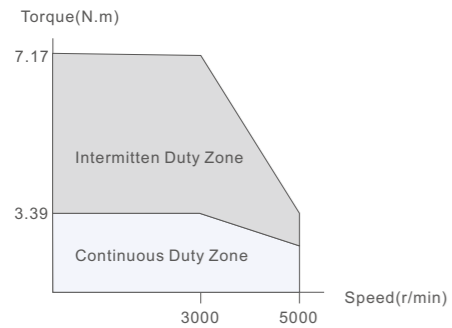

750W Motor

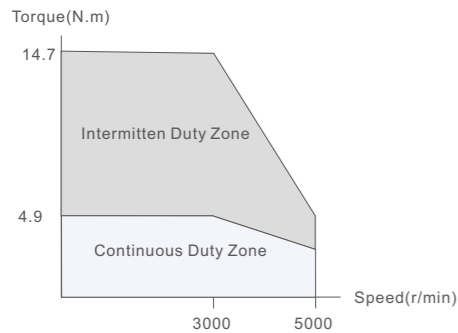

1500W Motor

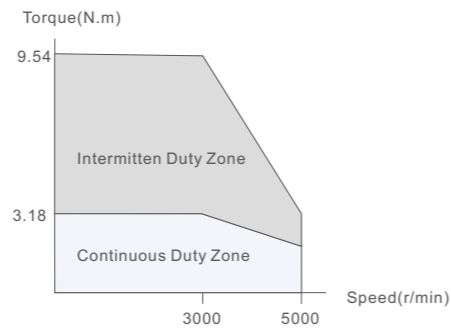

ELM2H - 1000W Motor

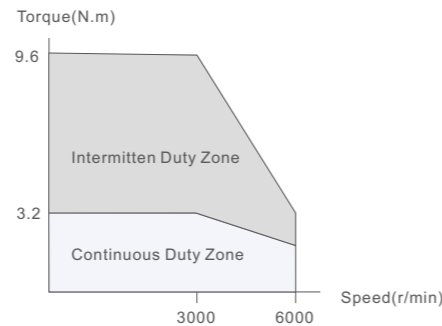

ELM2L - 1000W Motor

ELM2 Model	ELM2H-0850LD130ET-H	ELM2H-1300LD130ET-H	ELM2H-1800LD130ET-H
	ELM2H-0850LD130FT-H	ELM2H-1300LD130FT-H	ELM2H-1800LD130FT-H
Frame Size[mm]	130	130	130
Rated Power[W]	850	1300	1800
Rated Voltage[VAC]	380		
Rated Torque[Nm]	5.4	8.4	11.5
Peak Torque[Nm]	16.2	25.2	34.5
Rated Current[Arms]	3.5	4.8	6.5
Peak Current[Arms]	10.5	14.4	19.5
Rated Speed[r/min]	1500	1500	1500
Peak Speed[r/min]	3000	3000	3000
Inertia [kgm ² *10 ⁻⁴]	Without Brake	13.88	20.59
	With Brake	15.78	22.26
Weight (kg)	Without Brake	5.6	7.5
	With Brake	6.9	8.8
Permissible Load to Shaft (N)	Radial	490	490
	Axial	196	196
Encoder Type	23bit optical multi-turn		
Plug Type	Aviation connector-H		
Matching Cable	Motor Cable	CABLE-RZ*M*-H(V2.0)	
	Encoder Cable	Absolute: CABLE-7BMA*M*-HZ(V3.0) Incremental: CABLE-7BM*M*-HZ(V3.0)	
	Brake Cable	CABLE-SC*M*-H(V3.0)	
Matching Drive	Priority	EL7-**1000*	EL7-**1500* EL7-**2000*

• Dimensions

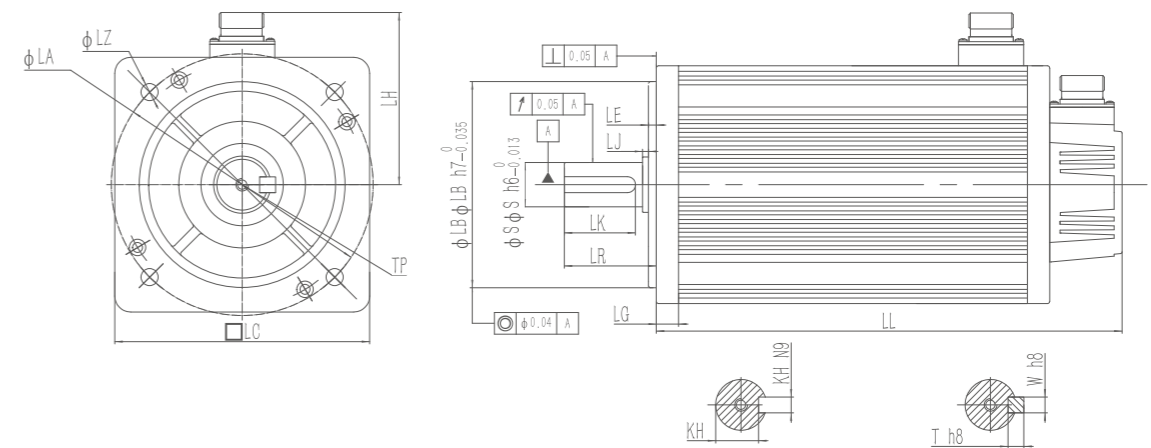

Motor Series	LL	LC	LR	LA	LZ	LH	LG	LE	LJ	S	LB	TP	LK	KH	kW	W	T
ELM2H-0850LD130FT-H	147	130	55	145	8.5	106	17.5	4	0.5	19	110	M6X20	30	16	5	5	5
ELM2H-0850LD130ET-H	172	130	55	145	8.5	106	17.5	4	0.5	19	110	M6X20	30	16	5	5	5
ELM2H-1300LD130FT-H	168	130	55	145	8.5	106	17.5	4	0.5	22	110	M6X20	30	18.5	6	6	6
ELM2H-1300LD130ET-H	192	130	55	145	8.5	106	17.5	4	0.5	22	110	M6X20	30	18.5	6	6	6
ELM2H-1800LD130FT-H	195	130	55	145	8.5	106	17.5	4	0.5	24	110	M6X20	30	19	8	8	8
ELM2H-1800LD130ET-H	219	130	55	145	8.5	106	17.5	4	0.5	24	110	M6X20	30	19	8	8	8

• Speed - Torque characteristics

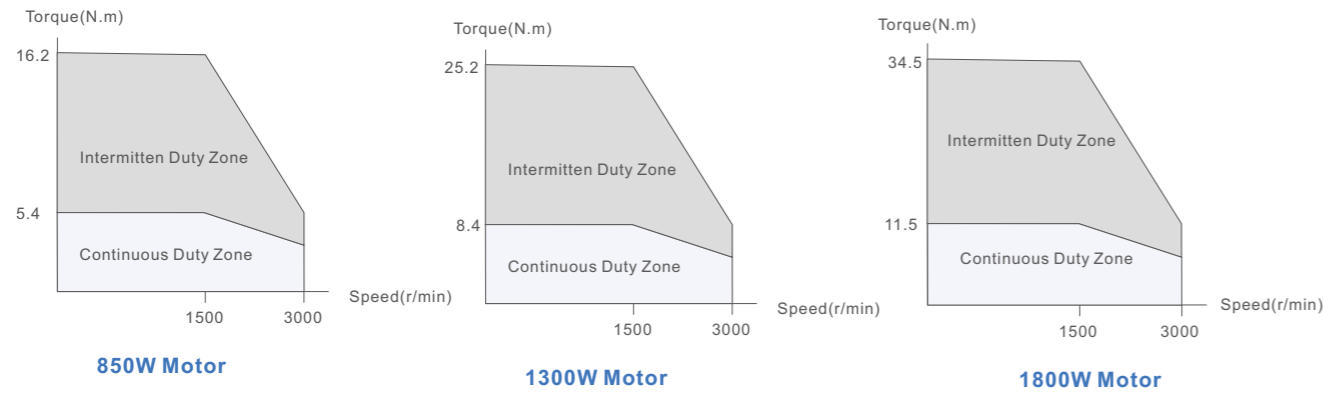

ELM2 Model	ELM2M-2900LD180FT-H	ELM2M-4400LD180FT-H	ELM2M-5500LD180FT-H	ELM2M-7500LD180FT-H
	ELM2M-2900LD180ET-H	ELM2M-4400LD180ET-H	ELM2M-5500LD180ET-H	ELM2M-7500LD180ET-H
Frame Size[mm]	180			
Rated Power[W]	2900	4400	5500	7500
Rated Voltage[VAC]	380			
Rated Torque[Nm]	18.6	28.4	35	48
Peak Torque[Nm]	55.8	85	87.5	119
Rated Current[Amps]	11.8	15.7	20.6	25.7
Peak Current[Amps]	35.4	47.1	51.5	64.5
Rated Speed[r/min]	1500	1500	1500	1500
Peak Speed[r/min]	3000	3000	3000	3000
Inertia [kgm ² *10 ⁻⁴]	Without Brake	56.8	78.2	109
	With Brake	65.3	86	118
Weight (kg)	Without Brake	16.3	21.4	25.8
	With Brake	21.8	26.5	31.1
Permissible Load to Shaft (N)	Radial	784	784	784
	Axial	343	343	343
Encoder Type	23bit optical multi-turn			
Plug Type	Aviation connector-H-180			
Matching Cable	Motor Cable	CABLE-RZA*M*-H-180(V1.0)	CABLE-RZB*M*-H-180(V1.0)	
	Encoder Cable	Absolute: CABLE-7BMA*M*-HZ-180(V1.0) Incremental: CABLE-7BM*M*-HZ-180(V1.0)		
	Brake Cable	CABLE-SC*M*-H-180(V1.0)		
Matching Drive	Priority	EL7-**3000*T	EL7-**4400*T	EL7-**5500*T
				EL7-**7500*T

• Dimensions

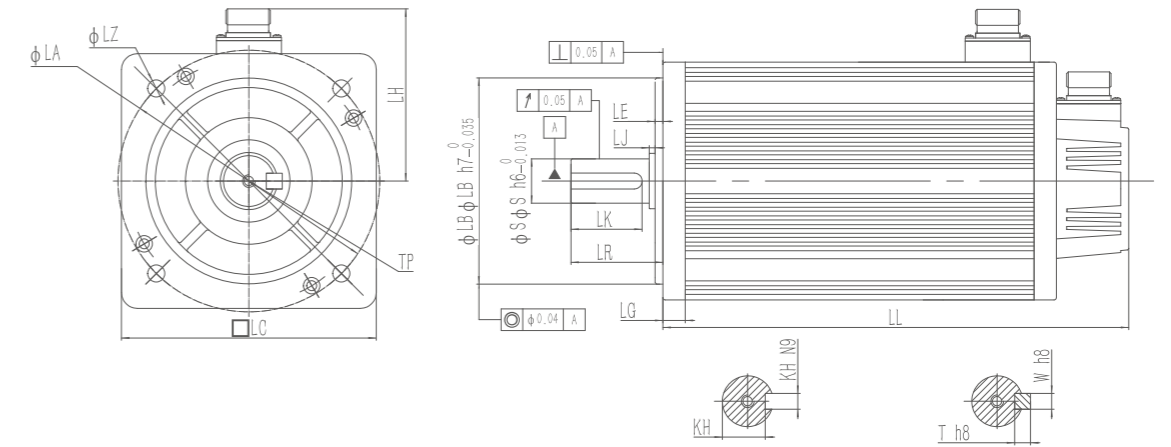

Motor Series	LL	LC	LR	LA	LZ	LH	LG	LE	LJ	S	LB	TP	LK	KH	kW	W	T
ELM2M-2900LD180FT-H	201	180	79	200	4-φ13.5	134	18	3.2	0.3	35	114	M12X25	65	30	10	10	8
ELM2M-2900LD180ET-H	249	180	79	200	4-φ13.5	134	18	3.2	0.3	35	114	M12X25	65	30	10	10	8
ELM2M-4400LD180FT-H	230	180	79	200	4-φ13.5	134	18	3.2	0.3	35	114	M12X25	65	30	10	10	8
ELM2M-4400LD180ET-H	278	180	79	200	4-φ13.5	134	18	3.2	0.3	35	114	M12X25	65	30	10	10	8
ELM2M-5500LD180FT-H	257	180	113	200	4-φ13.5	134	18	3.2	0.3	42	114	M16X32	96	37	12	12	8
ELM2M-5500LD180ET-H	305	180	113	200	4-φ13.5	134	18	3.2	0.3	42	114	M16X32	96	37	12	12	8
ELM2M-7500LD180FT-H	297	180	113	200	4-φ13.5	134	18	3.2	0.3	42	114	M16X32	96	37	12	12	8
ELM2M-7500LD180ET-H	345	180	113	200	4-φ13.5	134	18	3.2	0.3	42	114	M16X32	96	37	12	12	8

• Speed - Torque characteristics

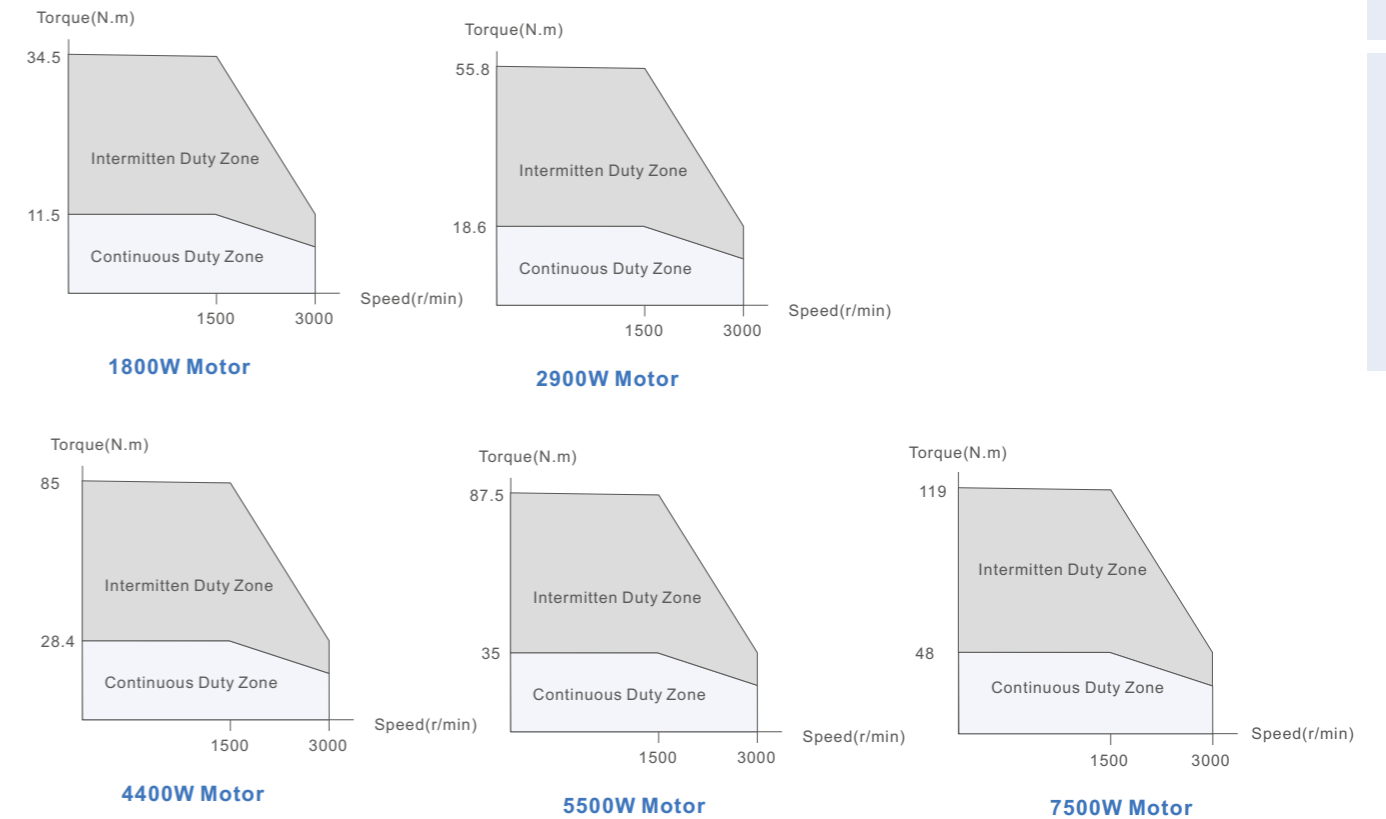

Accessories

Each servo drive comes with:

- (1) Power Connector
- (2) Signal Connector
- (3) Press Rod

• Extention Cables

Power Cables

- Length options: 1.5M, 3M, 5M, 7M, 10M, 13M
- Connector options: Direct connector / Aviation connector



Encoder Cables

- Length options: 1.5M, 3M, 5M, 7M, 10M, 13M
- Connector options: Direct connector / Aviation connector



■ Cable Details

Cable with Direct Connector Plug for Frame 40/60/80

(1) CABLE-RZH*M*-114-TS Motor Cable for Motor without Brake

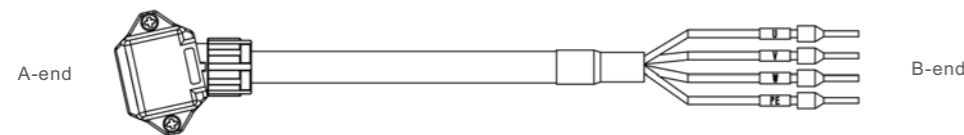

Pin Definition			
Diagram	A-end	Color	B-end
	1	Blue	U
	2	Red	W
	3	Black	V
	4	Yellow/Green	PE

Brake Cables

- Length options: 1.5M, 3M, 5M, 7M, 10M, 13M
- Connector options: Direct connector / Aviation connector



Configuration Cables

- Connect the drive to computer
- The interface standard is USB
- Mode: CABLE-USB1M5, CABLE-L6TS1M5



RS485/EtherCAT Communication Cables

- Model: CABLE-TX0M2-BUS
- Length options: 1.5M, 3M, 5M, 7M, 10M, 13M



(2) CABLE-RZH*M*-114-TS Motor Cable for Motor with Brake

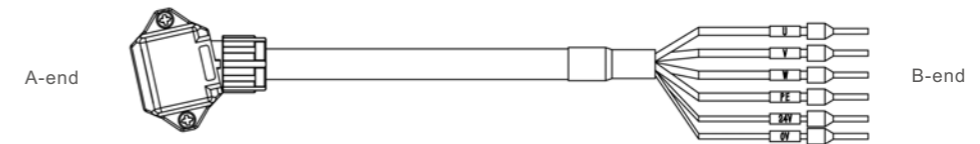

Pin Definition			
Diagram	A-end	Color	B-end
	1	Blue	U
	2	Red	W
	3	Black	V
	4	Yellow/Green	PE
	5	Black	0V
	6	Red	24V

(3) CABLE-BMAH*M*-124-TS Encoder Cable

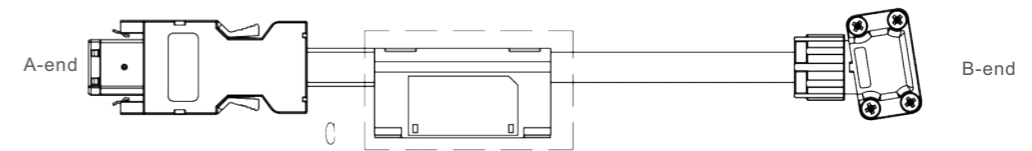

Pin Definition					
Diagram	A-end	Definition	B-end	Diagram	C-end
	1	PE	1		
	2	5V	2		
	3	0V	3		
	4	SD+	4		
	5	SD-	5		
	6	BAT+	6		1
	7	BAT-	7		2

Cable with H Plug for Frame 130

(1) CABLE-RZ*M*-H Power Cable

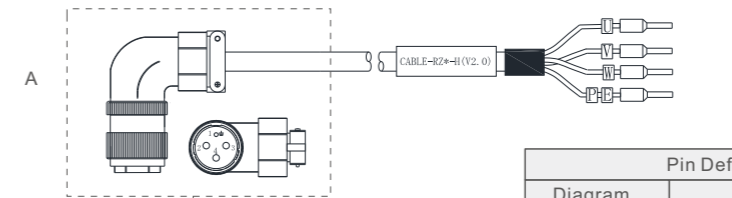

Material	Part No.	Quantity
Motor Cable Parts	Aviation Plug for Motor Cable	11600072 1

Pin Definition			
Diagram	Pin Definition		
	1	PE	Yellow
	2	U	Red
	3	V	Green
	4	W	Black

(2) CABLE-7BM*M*-HZ Encoder Cable

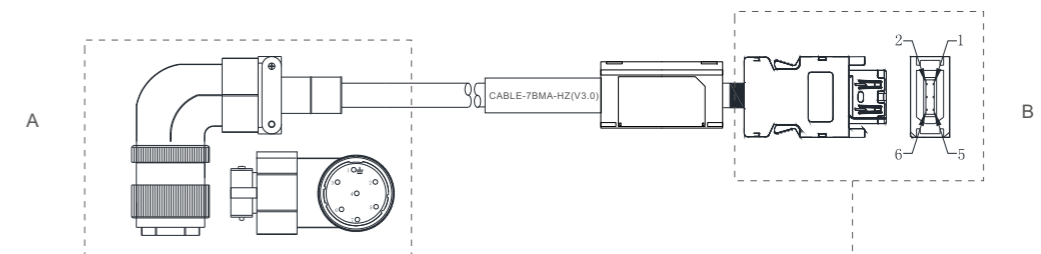

Material	Part No.	Quantity
Encoder Cable Parts	Aviation Plug for Encoder Cable	11600076 1

Material	Part No.	Quantity
Encoder Cable Parts	Plug Connected to Drive	11600383 1

		Pin Definition							
A-end	B-end	Pin Definition							
		Color	Shield	White	Black	Blue	Purple	Red	Yellow
A-end	1	2	3	4	5	6	7		
B-end	Shell	1	2	5	6	/	/		
Definition	Shield	+5V	0V	SD+	SD-	BAT+	BAT-		

(3) CABLE-SC*M*-H Brake Cable



Material	Quantity	Notes
Brake Cable Parts	1	Only for motor with brake

Pin Definition		
Diagram	Pin Definition	
	1	0V
	2	24V

Cable with HD Plug for Frame 130

(1) CABLE-RZ*M*-HD Motor Cable

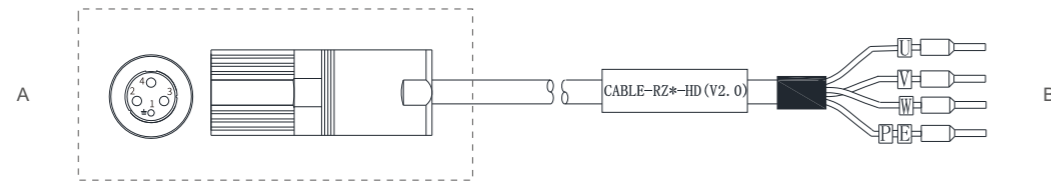

Material	Part No.	Quantity
Motor Cable Parts	11600077	1

Pin Definition			
Diagram	Pin Definition		
	1	PE	Yellow
	2	U	Red
	3	V	Green
	4	W	Black

(2) CABLE-7BM*M*-HD Encoder Cable

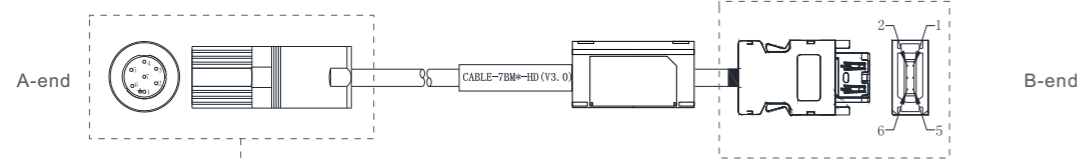

Material	Part No.	Quantity
Encoder Cable Parts	11600079	1

Material	Part No.	Quantity
Encoder Cable Parts	11600383	1

Pin Definition									
A-end	B-end	Pin Definition							
		Color	Shield	Red	Black	Blue	Blue/Black	Brown	Brown/Black
		A-end	1	7	5	6	4	3	2
B-end	Shell	1	2	5	6	/	/		
Definition	Shield	+5V	0V	SD+	SD-	BAT+	BAT-		

(3) CABLE-SC*M*-HD Brake Cable

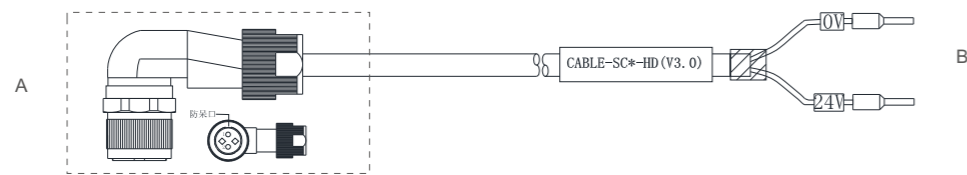

Material	Part No.	Quantity	Notes
Brake Cable Parts	11600078	1	Only for motor with brake

Pin Definition		
Diagram	Pin Definition	
	1	0V
	2	24V

Cable with Aviation Plug for Frame 180

(1) CABLE-RZA/B*M*-H-180 Motor Cable

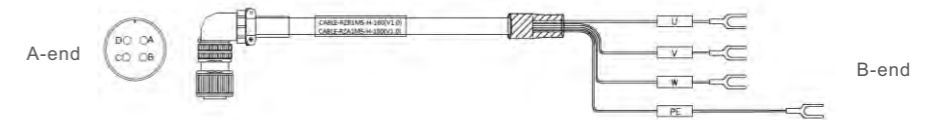

Material	Part No.	Quantity
Motor Cable Parts	11600980	1

CABLE-RZA*M*-H-180

Pin Definition			
Diagram	A-end	Color	B-end
	1	Blue	U
	2	Black	V
	3	Red	W
	4	Yellow/Green	PE

CABLE-RZB*M*-H-180

Pin Definition			
Diagram	A-end	Color	B-end
	1	White	U
	2	Black	V
	3	Red	W
	4	Yellow/Green	PE

(2) CABLE-7BMA*M*-HZ-180 Encoder Cable



Material	Part No.	Quantity
Encoder Cable Parts	11600979	1
Plug Connected to Drive	11600383	1
Battery Box	82600020	1

Pin Definition					
Diagram	A-end	Color	B-end	C-end	Definition
	10	Weave	Shell		PE
	2	White	1		5V
	3	Black	2		0V
	4	Blue	5		SD+
	5	Pink	6		SD-
	6	Red		1	E+
	7	Black		2	E-

(3) CABLE-SC*M*-H-180 Brake Cable

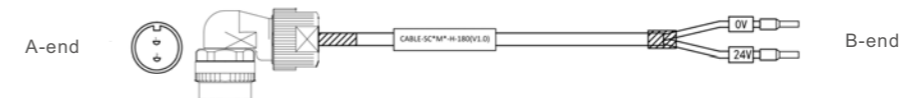

Material	Part No.	Quantity
Brake Cable Parts	11600978	1

Pin Definition			
Diagram	A-end	Color	B-end
	1	Black	0V
	2	Red	24V

DC Servo Drives

ELD2 Series



ELD2 Series DC Servo Drives

ELD2 series DC servo drive, power range from 50W to 2.5kW, adopt special DC input, motion control product designed for machines and applications that request a best balance between reasonable cost and outstanding performance with MFC/vibration suppression.

- Voltage : 24-70VDC
- Power range : 50W - 2.5kW
- Up to 180Amp peak current
- Compact size
- Pulse+Direction, analog input
- Modbus,CANopen
- Brushless motor & Brushed motor suitable

Easy Tuning

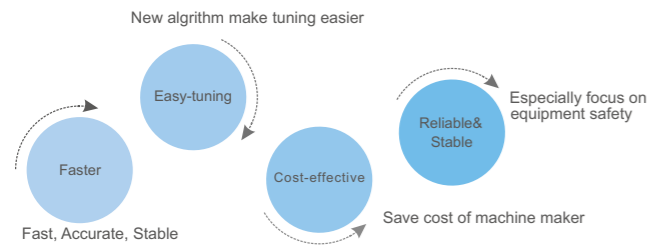

Motion Studio

- Convenient GUI user interface
- Easy Tuning
- Real-time motion state monitoring
- Error history and resolution guide

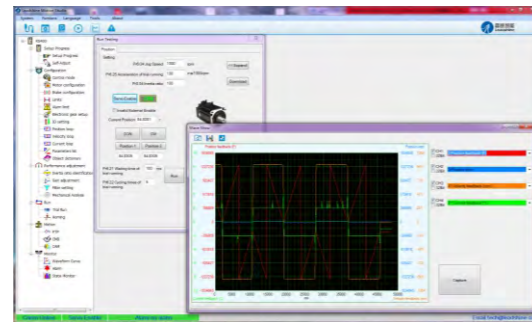

Supported Networks



Part Numbers

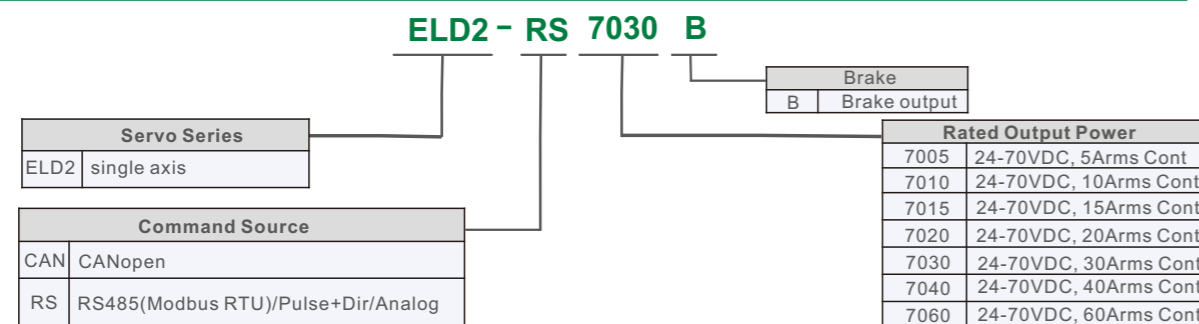

Specifications

Power & Environment				
Drive	ELD2-RS7005 ELD2-CAN7005B	ELD2-RS7010 ELD2-CAN7010B	ELD2-RS7015B ELD2-CAN7015B	ELD2-RS7020B ELD2-CAN7020B
Dimensions(mm)	118*75.5*25.5(RS7005) 140*79.5*25.5(CAN7005B)	118*75.5*25.5(RS7010) 140*79.5*25.5(CAN7010B)	175*101.5*33	175*100.5*33
Rated Power (kW)	0.1	0.4	0.6	0.75
Rated Output Current (Arms)	5	10	15	20
Max Output Current (Apeak)	21	35(RS7010) 42(CAN7010)	45	80
Main Power	Voltage (V)	DC24-70	DC24-70	DC24-70
	Current (Arms)	5Arms (≤48VDC) 3.5Arms (>48VDC)	10Arms (≤48VDC) 7Arms (>48VDC)	15Arms (≤48VDC) 11Arms (>48VDC)
Logic Power	Voltage (V)	-	-	-
Control Method	IGBT PWM Sinusoidal Wave Drive			
Overload	300%(3s)			
Brake Resistor	External Connection			
Communication Interface	RS485/CAN			
Protection Class	IP20			

Power & Environment				
Drive	ELD2-RS7030B ELD2-CAN7030B	ELD2-RS7040B ELD2-CAN7040B	ELD2-RS7060B ELD2-CAN7060B	
Dimensions(mm)	175*100.5*33	194*103*41	194*103*41	
Rated Power (kW)	1.2	1.5	2.5	
Rated Output Current (Arms)	30	40	60	
Max Output Current (Apeak)	90	120	180	
Main Power	Voltage (V)	DC24-70	DC24-70	DC24-70
	Current (Arms)	30Arms (≤48VDC) 21Arms (>48VDC)	40Arms (≤48VDC) 28Arms (>48VDC)	60Arms (≤48VDC) 42Arms (>48VDC)
Logic Power	Voltage (V)	-	DC24-70	DC24~70
Control Method	IGBT PWM Sinusoidal Wave Drive			
Overload	300%(3s)			
Brake Resistor	External Connection			
Communication Interface	RS485/CAN			
Safe function	-	STO		
Protection Class	IP20			

CANopen Specifications	
Link Layer Protocol	CAN Field-bus
Application Layer Protocol	CANopen protocol
CAN-ID Type	CAN 2.0A
Communication Rate	1Mbit/s, 500Kbit/s, 250Kbit/s, 125Kbit/s, 100Kbit/s, 50Kbit/s, 20Kbit/s
Sub-protocol	DS 301 V4.02: CANopen application layer protocol and communication protocol DSP 402 V2.0: Device profile for drives and motion control
CANopen Length	0 - 8-bit
Support Service	NMT: Network Management Service SDO: Service Data Object PDO: Process Data Object Devices Monitor: Node protection and heartbeat message SYNC: Synchronous generator and synchronous detection, applied to the PDO transmission EMCY: Emergency object Services
PDO Transmission Modes	Time trigger, event trigger, asynchronization/synchronization trigger(configurable)
PDO Number	4 TPDOs, 4 RPDOs
Control Methods	PP (Profile Position) PV (Profile Velocity) PT (Profile Torque) HM (Homing)

Communication & Connection		
	ELD2-RS	ELD2-CAN
Pulse Input	2 fast pulse input, 5V-24V only	-
Pulse Encoder Output	5V differential outputs, A/B phase	5V differential outputs, A/B phase
Digital Input/Output	4 programmable OC inputs, 2 programmable OC outputs, 24V	4 programmable OC inputs, 2 programmable OC outputs, 24V
Analog Input	1 analog input: -10V to +10V	-
Feedback Supported	1000-Line, 2500-Line, 17-bit incremental encoder	

Matched Motors	
Motor Model	ELVM Series / Third-party Brushless + Brushed motor
Power Range	50W - 2.5kW
Voltage Range	24 - 70VDC
Encoder Type	1000-Line, 2500-Line, 17-bit
Motor Size	40mm, 42mm, 57mm, 60mm, 80mm 110mm, 130mm Frame Size
Other Requirements	Brake. oil-seal. protection level. shaft & connector can be customized

Dimensions

• ELD2-RS7005/ELD2-RS7010

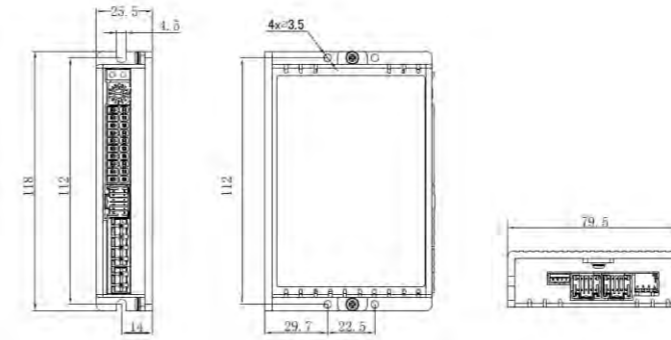

• ELD2-CAN7005B/ELD2-CAN7010B

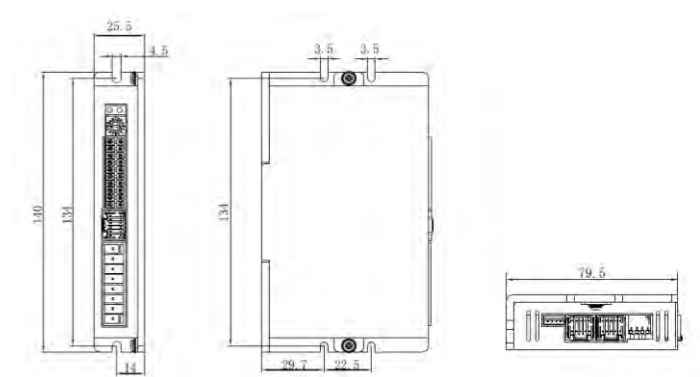

• ELD2-**7015B/ELD2-**7020B/ELD2-**7030B

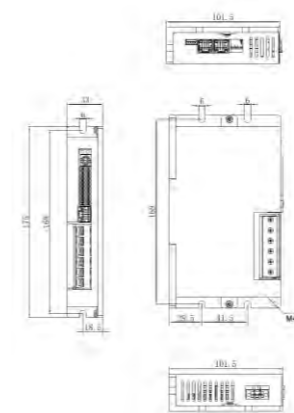

• ELD2-**7040B/7060B

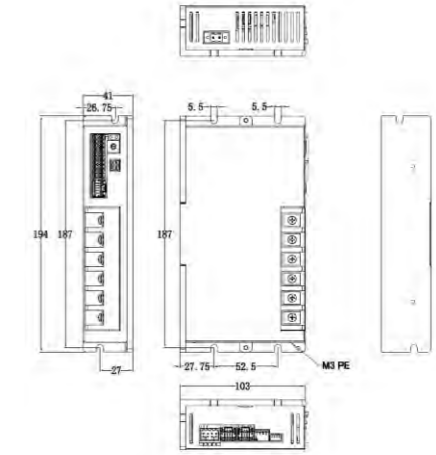

Applications



Printing Machines



Logistics



AGV Machines



Medical

DC Servo Drives

2ELD2 Dual-axis Servo Drives



2ELD2 Dual-axis Servo Drives

The 2ELD2 series is a new low voltage DC servo drive developed from Leadshine, dual-axis, that one 2ELD2 drive can drive two DC servo motors at the same time. 2ELD2 series keep the same performance of ELD2 series, relying on the special dual-axis structure, 2ELD2 series achieve less wiring, space saving, energy saving, while having a high cost performance. 2ELD2 series can be applied to mobile robots, logistics, electronics, CNC machine and other industries.

- Each axis power range up to 1.2kW
- Each axis current range up to 90Amp
- STO and Auxiliary input power
- Pulse+Direction, analog input
- Modbus, CANopen
- Brushless motor & Brushed motor suitable

Motion Studio

- Convenient GUI user interface
- Easy Tuning
- Real-time motion state monitoring
- Error history and resolution guide

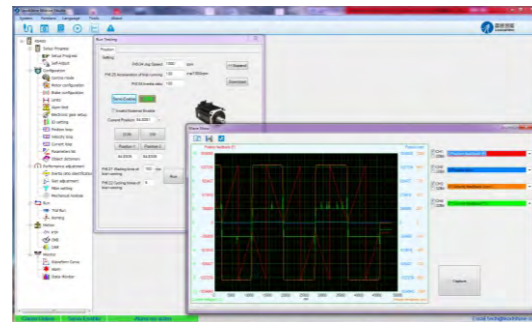

Easy Tuning

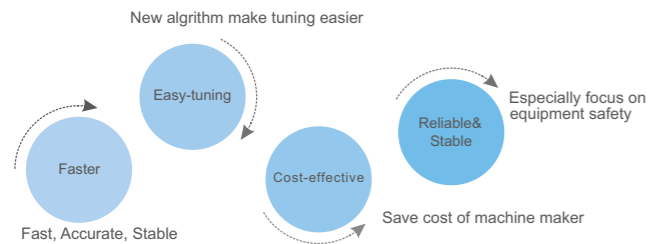

Supported Networks

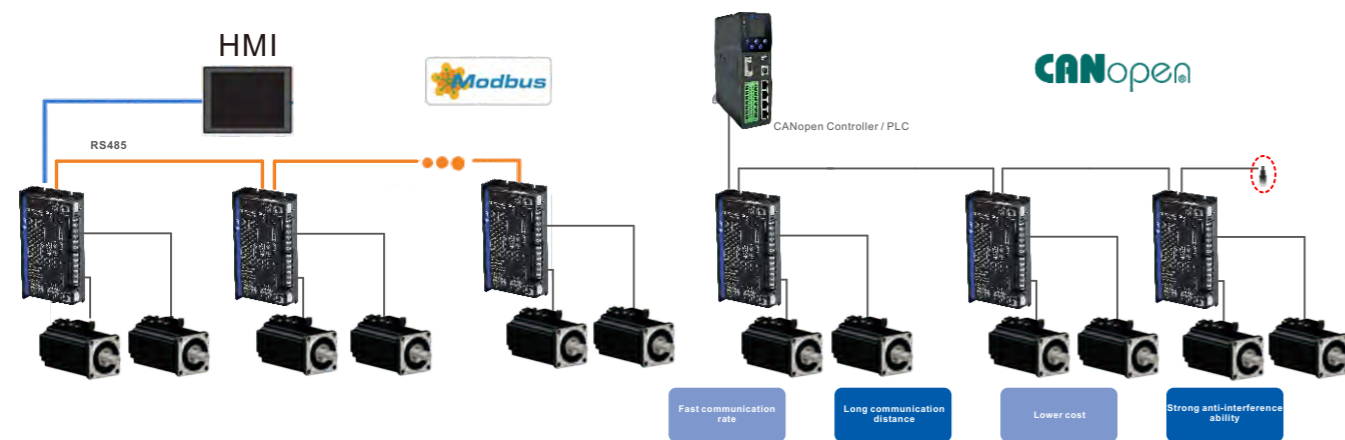

Part Numbers

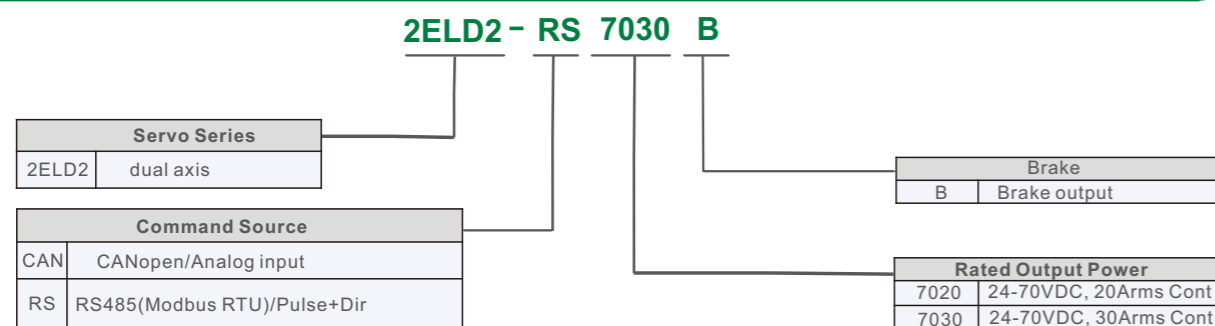

Specifications

Power & Environment		
Drive	2ELD2-RS7020B 2ELD2-CAN7020B	2ELD2-RS7030B 2ELD2-CAN7030B
Dimensions(mm)	194*103*41	194*103*41
Rated Power (kW)/Each Channel	0.75	1.2
Rated Output Current (Arms) /Each Channel	20	30
Max Output Current (Apeak) /Each Channel	80	90
Main Power	Voltage (V)	DC24-70
	Current (Arms)	40Arms (≤48VDC) 28Arms (>48VDC)
Logic Power	Voltage (V)	DC24~70
Control Method	IGBT PWM Sinusoidal Wave Drive	
Overload	300%(3s)	
Brake Resistor	External Connection	
Communication Interface	RS485/CAN	
Safe function	STO	
Protection Class	IP20	
CANopen Specifications		
Link Layer Protocol	CAN Field-bus	
Application Layer Protocol	CANopen protocol	
CAN-ID Type	CAN 2.0A	
Communication Rate	1Mbit/s, 500Kbit/s, 250Kbit/s, 125Kbit/s, 100Kbit/s, 50Kbit/s, 20Kbit/s	
Sub-protocol	DS 301 V4.02: CANopen application layer protocol and communication protocol DSP 402 V2.0: Device profile for drives and motion control	
CANopen Length	0 - 8-bit	
Support Service	NMT: Network Management Service SDO: Service Data Object PDO: Process Data Object Devices Monitor: Node protection and heartbeat message SYNC: Synchronous generator and synchronous detection, applied to the PDO transmission EMCY: Emergency object Services	
PDO Transmission Modes	Time trigger, event trigger, asynchronization/synchronization trigger(configurable)	
PDO Number	4 TPDOs, 4 RPDOs	
Control Methods	PP (Profile Position), PV (Profile Velocity) PT (Profile Torque), HM (Homing)	
Communication & Connection		
	2ELD2-RS	2ELD2-CAN
Pulse Input	2 fast pulse input, 5V-24V only	-
Pulse Encoder Output	5V differential outputs, A/B phase	5V differential outputs, A/B phase
Digital Input/Output	4 programmable OC inputs, 2 programmable OC outputs, 24V	4 programmable OC inputs, 2 programmable OC outputs, 24V
Analog Input	-	1 analog input: -10V to +10V
Feedback Supported	1000-Line, 2500-Line, 17-bit incremental encoder	
Matched Motors		
Motor Model	ELVM Series / Third-party Brushless + Brushed motor	
Power Range	50W - 1.2kW	
Voltage Range	24 - 70VDC	
Encoder Type	1000-Line, 2500-Line, 17-bit	
Motor Size	40mm, 42mm, 57mm, 60mm, 80mm 110mm, 130mm Frame Size	
Other Requirements	Brake, oil-seal, protection level, shaft & connector can be customized	

Dimensions

- 2ELD2-**7020B/7030B

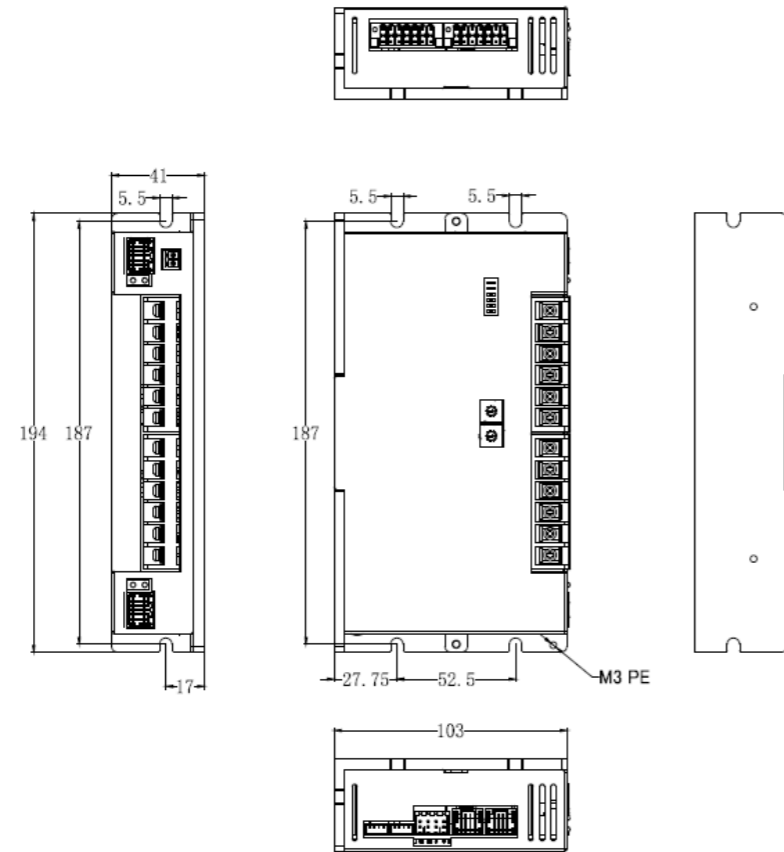

Applications



Printing Machines

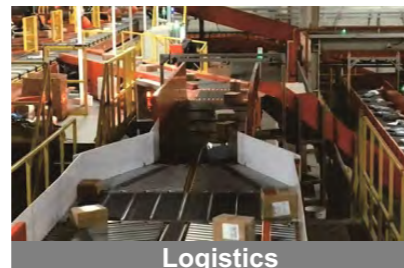

Logistics



AGV Machines



Medical

DC Servo Motors ELVM Series



- Power rating: 50W - 1000W
- Frame size: 40mm, 60mm, 80mm;
- Voltage range: 24 - 60VDC
- Feedback: 2500-Line incremental encoder; 17-bit absolute encoder
- Protection: IP65

The ELVM series is a new low voltage servo motor series designed of Lead Shine with power ranging from 50W to 1000W, with 2500-Line incremental encoder or 17-bit/23-bit absolute encoder, featuring short length, high overload capacity, good vibration resistance and IP65 protection.

Part Numbers

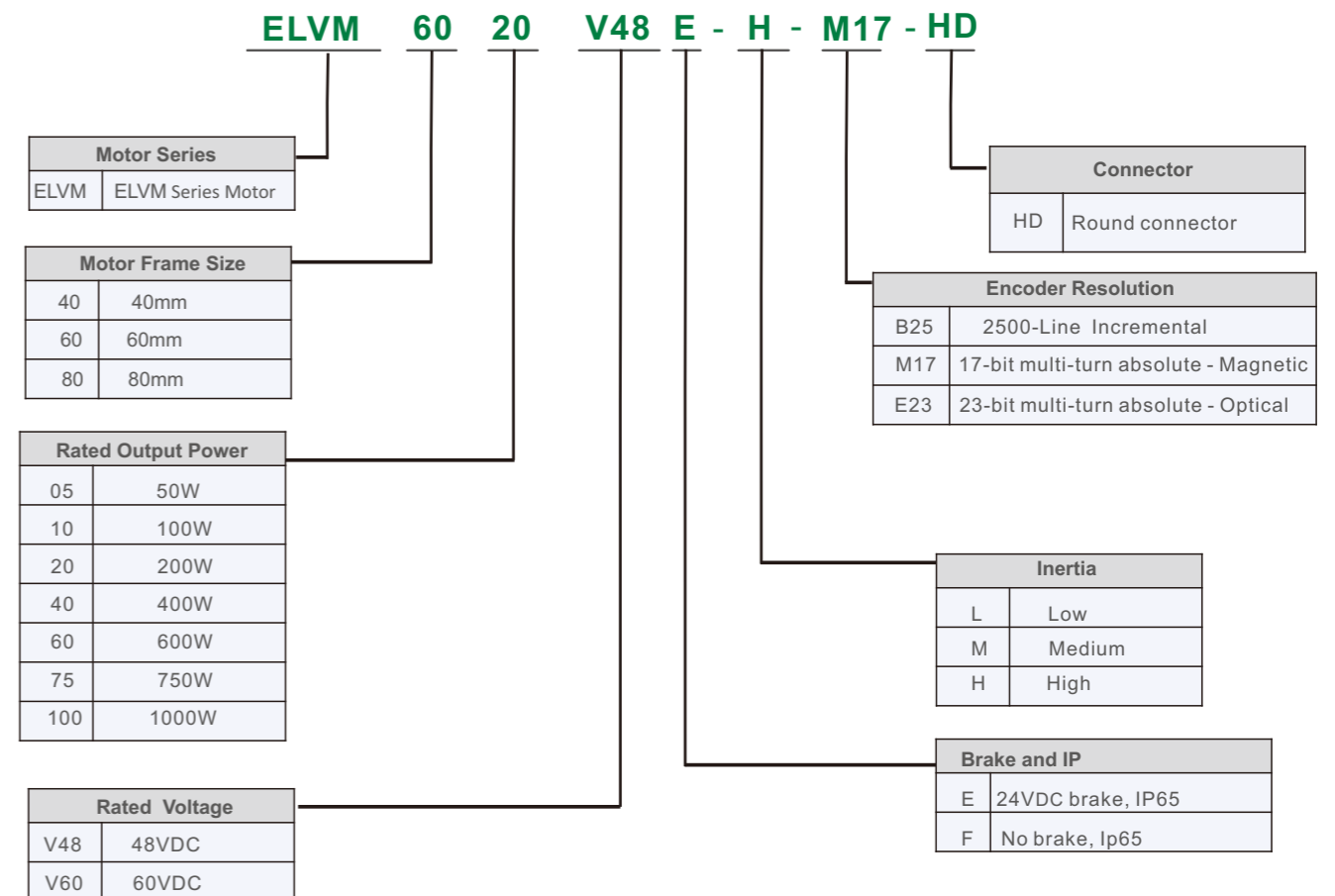

Servo Motors with 2500-Line/17-bit Encoders

• Models

ELVM Series	6020V24FH-**	6020V48FH-**	6040V24FH-**	6040V48FH-**	6060V48FH-**	8075V48FH-**	80100V48FH-**	
	6020V24EH-**	6020V48EH-**	6040V24EH-**	6040V48EH-**	6060V48EH-**	8075V48EH-**	80100V48EH-**	
Frame Size [mm]	60				80			
Rated Power [W]	200	200	400	400	600	750	1000	
Voltage [VDC]	24	48	24	48	48	48	48	
Rated Torque [Nm]	0.64	0.64	1.27	1.27	1.91	2.39	3.2	
Rated Current [Arms]	10	6	19.9	10	15	19	28	
Rated Speed [r/min]	3000	3000	3000	3000	3000	3000	3000	
Peak Torque [Nm]	1.92	1.92	3.81	3.81	5.73	7.17	9.6	
Peak Current [Arms]	31	19.6	61.7	31	49.3	59	87	
Max Speed [r/min]	4000	4000	4000	4000	4000	3500	3500	
Torque Const [Nm/A]	0.064	0.107	0.064	0.127	0.127	0.126	0.11	
Voltage Const [V/krpm]	4.1	6.9	4.1	8.3	8.3	8.4	7.6	
Resistance [Ω]	0.18	0.47	0.07	0.28	0.17	0.09	0.049	
Inductance [mH]	0.33	0.92	0.14	0.52	0.34	0.38	0.25	
Inertia [kgm ² ·10 ⁻⁴]	Standard	0.29	0.29	0.58	0.58	0.83	1.5	1.8
	With Brake	0.3	0.3	0.59	0.59	0.84	1.65	1.95
Encoder	2500-Line/17-bit Incremental Encoder							
Structure	Totally Enclosed, Natural Cooling (IP rating: IP65)							
Weight (kg)	Standard	1.03	1.03	1.32	1.32	1.59	2.21	2.6
	With Brake	1.38	1.38	1.67	1.67	2	2.79	3.2
Permissible Load for the Shaft	L [mm]	22.5	27	27	27	27	27	27
	Radial [N]	254	254	254	254	254	392	392
	Thrust [N]	74	74	74	74	74	147	147

The pin assignment of 17-bit encoder

Pin	Name
1	GND
2	5V
3	0V
4	SD+
5	SD-
6	BAT+
7	BAT-

The pin assignment of 2500-Line encoder

Pin	Name	Pin	Name
1	PE	5	Z-
2	+5V	6	HU+
3	GND	8	HU-
9	EA+	10	HV+
13	EA-	12	HV-
4	EB+	11	HW+
14	EB-	15	HW-
7	Z+		

• Dimensions

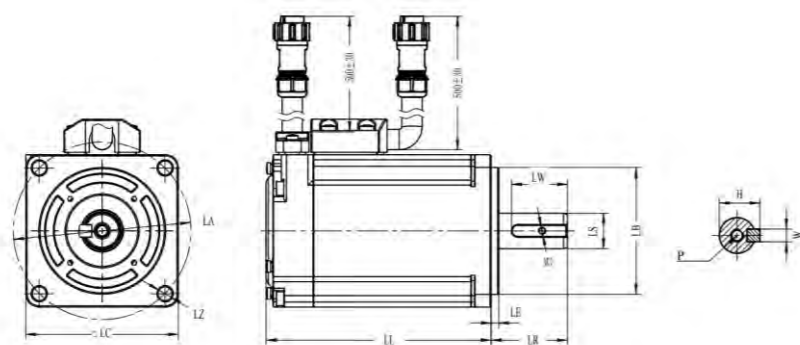

Motor Series	LC (mm)	LZ (mm)	LA (mm)	LS (mm)	LB (mm)	LL (mm)	LR (mm)	LE (mm)	LW (mm)	W (mm)	H (mm)	TP (mm)
ELVM6020V24FH-**	60	Φ5.5	Φ70	Φ14	Φ50	71.6	30	2.5	22	5	16	M3 1/2
ELVM6020V24EH-**	60	Φ5.5	Φ70	Φ14	Φ50	100.9	30	2.5	22	5	16	M3 1/2
ELVM6020V48FH-**	60	Φ5.5	Φ70	Φ14	Φ50	71.6	30	3	22	5	16	M5 1/2
ELVM6020V48EH-**	60	Φ5.5	Φ70	Φ14	Φ50	100.9	30	3	22	5	16	M5 1/2
ELVM6040V24FH-**	60	Φ5.5	Φ70	Φ14	Φ50	88.6	30	3	22	5	16	M5 1/2
ELVM6040V24EH-**	60	Φ5.5	Φ70	Φ14	Φ50	117.9	30	3	22	5	16	M5 1/2
ELVM6040V48FH-**	60	Φ5.5	Φ70	Φ14	Φ50	88.6	30	3	22	5	16	M5 1/2
ELVM6040V48EH-**	60	Φ5.5	Φ70	Φ14	Φ50	117.9	30	3	22	5	16	M5 1/2
ELVM6060V48FH-**	60	Φ5.5	Φ70	Φ14	Φ50	108.6	30	3	22	5	16	M5 1/2
ELVM6060V48EH-**	60	Φ5.5	Φ70	Φ14	Φ50	137.9	30	3	22	5	16	M5 1/2
ELVM8075V48FH-**	80	Φ6.6	Φ90	Φ19	Φ70	90.9	35	3	25	6	21.5	M5 1/2
ELVM8075V48EH-**	80	Φ6.6	Φ90	Φ19	Φ70	121.9	35	3	25	6	21.5	M5 1/2
ELVM80100V48FH-**	80	Φ6.6	Φ90	Φ19	Φ70	103.9	35	3	25	6	21.5	M5 1/2
ELVM80100V48EH-**	80	Φ6.6	Φ90	Φ19	Φ70	134.9	35	3	25	6	21.5	M5 1/2

Ordering Information

Frame (mm)	Motor	Drive	Cable					
	Motor Model	Drive Model	Power Cable	Encoder Cable	Brake Cable	Communication Cable	Software Configuration Cable	
60	ELVM6020V24FH-**	ELD2-CAN7010B	CABLE-RZD*M*-143	CABLE-BMAD*M*-223 (Multi-turn)	×	CABLE-TX*M*-LD2	CABLE-PC-1	
	ELVM6020V24EH-**				CABLE-SCD*M*-113			
	ELVM6020V48FH-**	ELD2-RS7010	CABLE-RZD*M*-123		×			
	ELVM6020V48EH-**				CABLE-SCD*M*-113			
	ELVM6040V24FH-**	ELD2-CAN7020B	CABLE-RZD*M*-253		×			
	ELVM6040V24EH-**				CABLE-SCD*M*-113			
	ELVM6040V48FH-**	ELD2-CAN7010B	CABLE-RZD*M*-143		CABLE-BMD*M*-213 (Single-turn)			×
	ELVM6040V48EH-**							CABLE-SCD*M*-113
	ELVM6060V48FH-**	ELD2-CAN7015B	CABLE-RZD*M*-253					×
	ELVM6060V48EH-**							CABLE-SCD*M*-113
80	ELVM8075V48FH-**	ELD2-CAN7020B	CABLE-RZD*M*-263	×				
	ELVM8075V48EH-**			CABLE-SCD*M*-113				
	ELVM80100V48FH-**	ELD2-CAN7030B	CABLE-RZD*M*-263	×				
	ELVM80100V48EH-**			CABLE-SCD*M*-113				
Photos								

Note:
 M means cable length, e.g. "0M5" means 0.5 m, "1M0" means 1 m.
 The 0.5 m/1.5 m/3 m/5 m cables are always in stock.

Integrated Servo Motors

iSV2 Series

- Power rating: 200W~750W
- 24VDC~60VDC
- Compact size, save mounting space
- Easy configuration



Leadshine iSV2 series includes 60mm & 80mm frame size servomotors which are integrated with 17-bit encoders and servo drives. Its power ranges from 200 to 750W with peak torque to 7.2 Nm. At very compact size an iSV2 integrated servo motor can save mounting space, eliminate encoder & power cable connections, reduce interference, and reduce system cost.

iSV2-RS Series iSV2-RS Series Drive



Position/Internal velocity mode

- RS485 based on Modbus / Pulse+Direction compatible
- Digital input and Digital output allows sink connection/source connection
- 17-bit incremental encoder
- GUI Software - MotionStudio
- Online Inertia Ratio Identification
- Motor with brake or without brake
- DIP switch for Modbus communication setting
- 120Ω on board termination resistor(DIP switch selection)

iSV2-CAN Series iSV2-CAN Series Drive



Profile Position/Profile Velocity/Profile Torque/Homing

- CANopen (CiA 301 & DS402)
- 4 RPDO & 4 TPDO
- Digital input and Digital output allows sink connection/source connection
- 17-bit incremental encoder
- GUI Software - MotionStudio
- Online Inertia Ratio Identification
- Motor with brake or without brake
- DIP switch for CAN communication setting
- 120Ω on board termination resistor(DIP switch selection)

Part Numbers

iSV2 - CAN 6040 V48 G

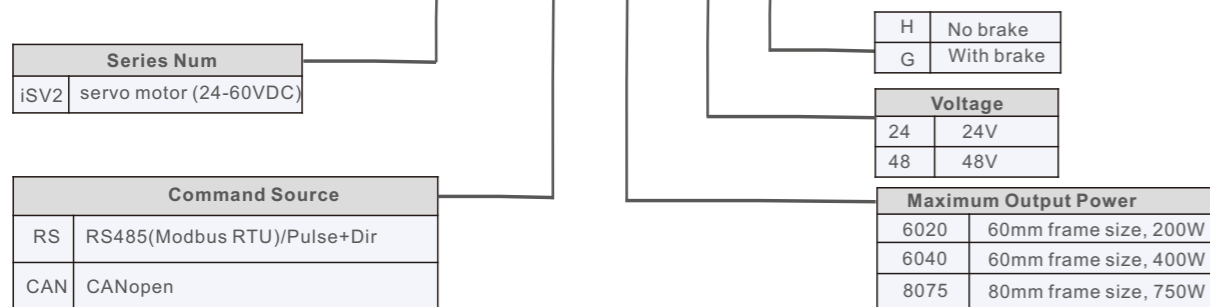

Specifications

Models	iSV2-RS6020V24* iSV2-CAN6020V24*	iSV2-RS6020V48* iSV2-CAN6020V48*	iSV2-RS6040V48* iSV2-CAN6040V48*	iSV2-RS8075V48* iSV2-CAN8075V48*
Modes of operation(iSV2-RS)	Position/Internal Velocity			
Modes of operation(iSV2-CAN)	Profile Position/Profile Velocity/Profile Torque/Homing			
Command source(iSV2-RS)	Pulse+Direction/Modbus RTU/16 PR paths			
Command source(iSV2-CAN)	CANopen			
Inputs/Outputs	4 programmable digital inputs, allow sink input/source input, within the range from 12VDC to 24VDC, 30mA 2 programmable single-end outputs			
Feedback Supported	17-bit Incremental			
Communication	CANopen/Modbus RTU(RS485)			

Drive model	iSV2-RS6020V24* iSV2-CAN6020V24*	iSV2-RS6020V48* iSV2-CAN6020V48*	iSV2-RS6040V48* iSV2-CAN6040V48*	iSV2-RS8075V48* iSV2-CAN8075V48*
Input Voltage(VDC)	24-60	24-60	24-60	24-60
Rated Power(W)	200	200	400	750
Rated Torque(Nm)	0.64	0.64	1.27	2.4
Peak Torque(Nm)	1.92	1.92	3.81	7.2
Rated Speed(rpm)	3000	3000	3000	3000
Peak Speed(rpm)	4000	4000	4000	4000
Rated Voltage(VDC)	24	48	48	48
Weight(kg)	0.93(1.32)	1.1(1.4)	1.26(1.65)	2.52(3.19)
Continuous Current(Arms)	11	6.5	10	19
Peak Current(Arms)	34	20	28	57
Back EMF Const(V/krpm)	3.6	6.3	8.3	8.6
Inertia(kg*m ² *10 ⁻⁴)	0.29	0.29	0.58	1.5
Logic Signal Current(mA)	10	10	10	10
Isolation Resistance(MΩ)	100	100	100	100
Control method	IGBT PWM sinusoidal Wave Drive			
Overload	250% ~ 300%			
Brake resistor	External connection			
Protection class	IP20			

Figures in () represent the weight with brake.

Motion Studio - GUI Software

- Information such as parameter setting and monitoring are consolidated easily just by connecting a personal computer to servo drive.
- Display parameter setting in list or visual formats, and set parameters by selecting from the drop down list
- Adjust control gain finely on the [Tuning] window manually for better performance.
- State monitoring and 4 channel wave showing with high accuracy.
- Easy to set the values of object dictionary for drive with CANopen version.
- Easy to read/save/download/compare/reset all parameters.

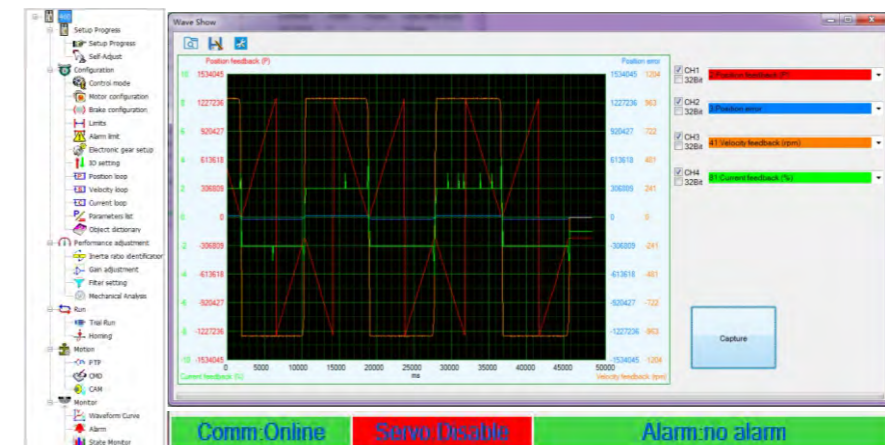

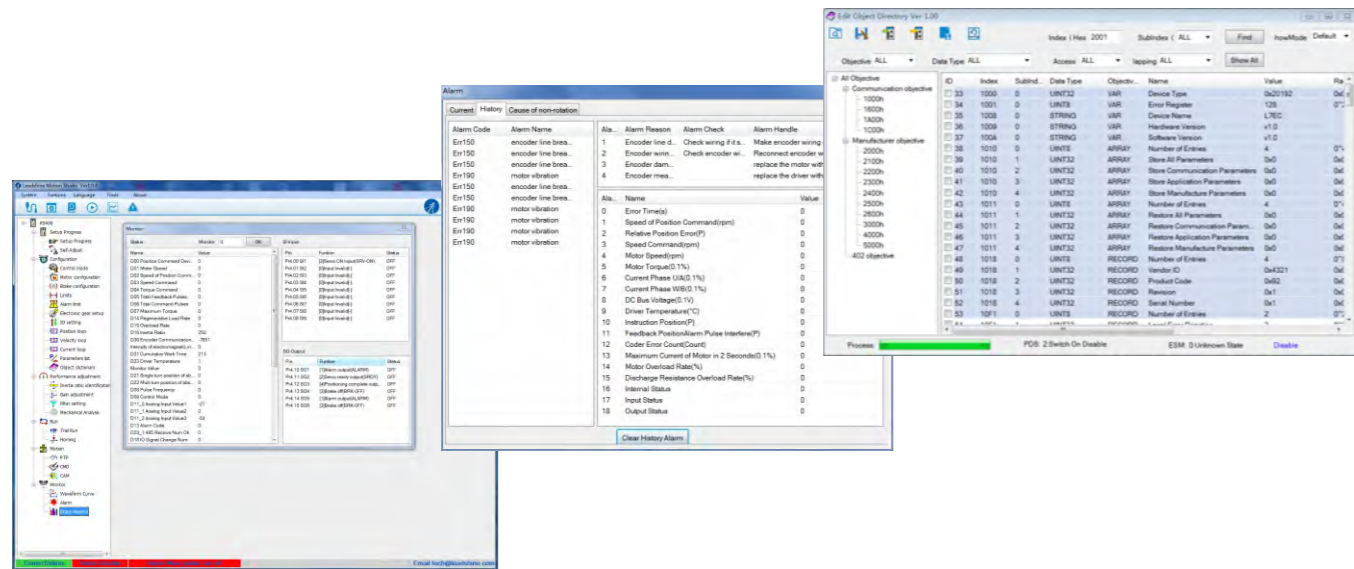

Servo Motor Pin Assignments



External Regeneration Resistors

	Recommend resister value(Ω)	Recommend resister power(W)
iSV2-CAN6020V48	10	50
iSV2-CAN6040V48	10	50
iSV2-CAN8075V48	10	100

Dimensions

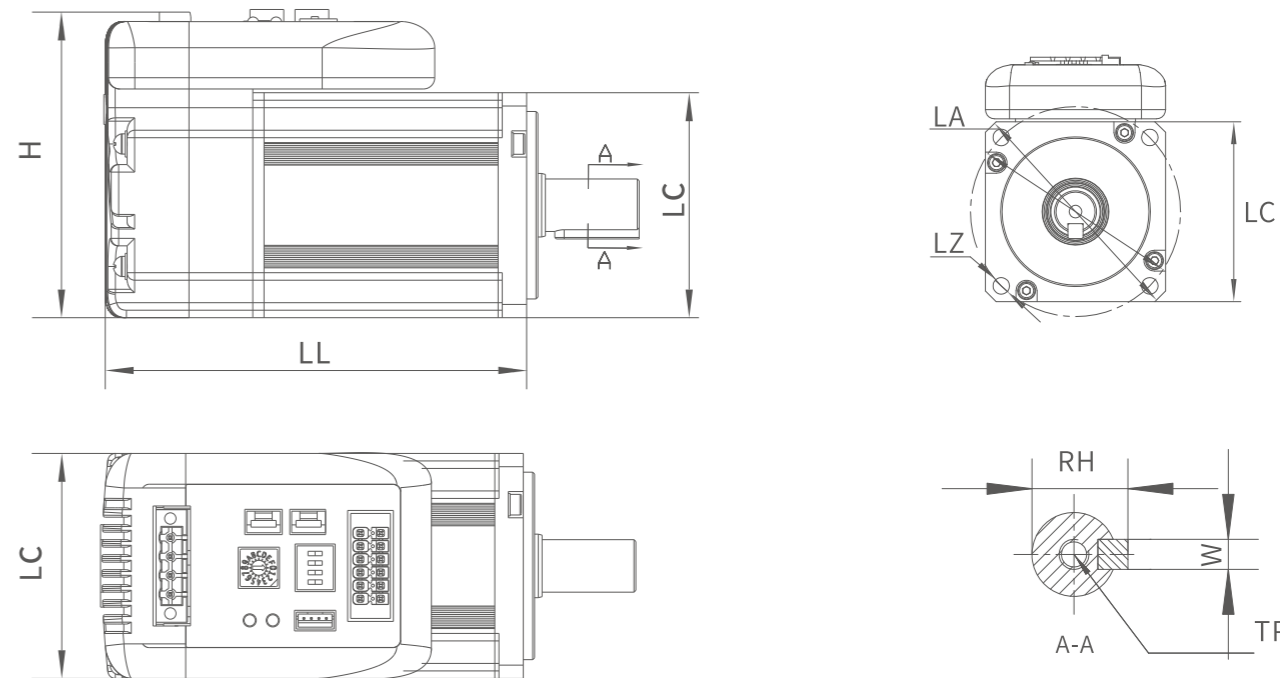

Model	LC (mm)	LL (mm)	H (mm)	LA (mm)	LZ (mm)	TP (mm)	RH (mm)	W (mm)
iSV2-CAN6020V24H iSV2-RS6020V24H	60	95.7	79	$\Phi 70$	$\Phi 5.5$	$\downarrow 12$	16	5
iSV2-CAN6020V24G iSV2-RS6020V24G		124.7						
iSV2-CAN6020V48H iSV2-RS6020V48H		95.7						
iSV2-CAN6020V48G iSV2-RS6020V48G		124.7						
iSV2-CAN6040V48H iSV2-RS6040V48H		112.7						
iSV2-CAN6040V48G iSV2-RS6040V48G		141.7						
iSV2-CAN8075V48H iSV2-RS8075V48H	80	128.8	100	$\Phi 90$	$\Phi 6.6$		21.5	6
iSV2-CAN8075V48G iSV2-RS8075V48G		160.3						

Figures in () represent the dimensions with brake.

Speed - Torque characteristics

- 200W motor(iSV2-**20)

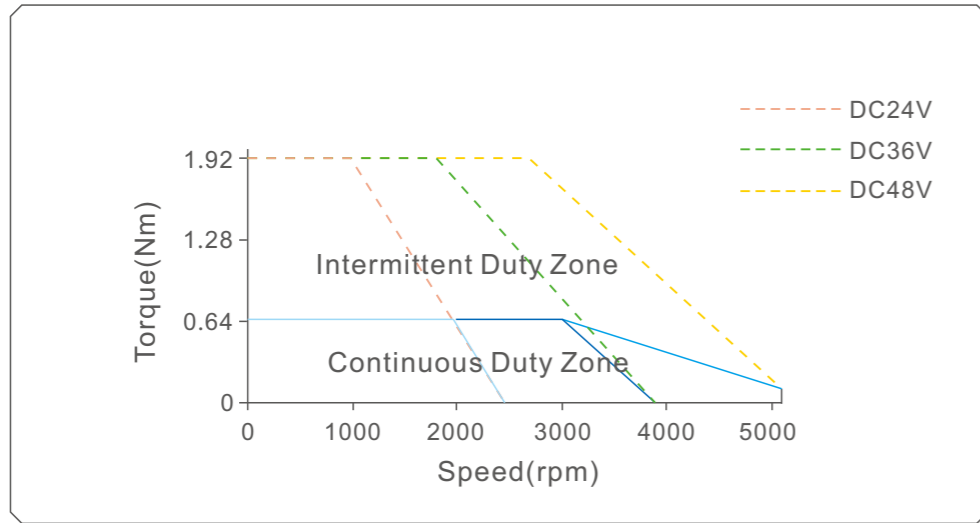

- 400W motor(iSV2-**40)

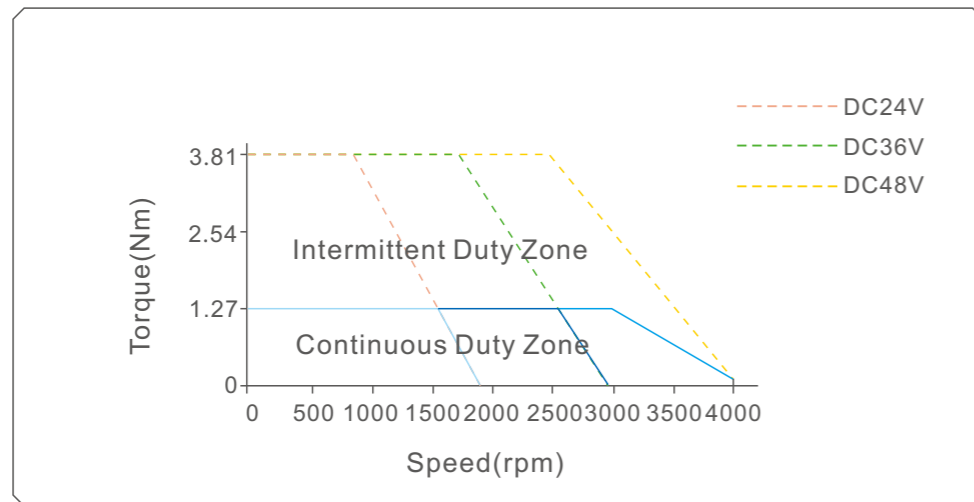

- 750W motor(iSV2-**75)

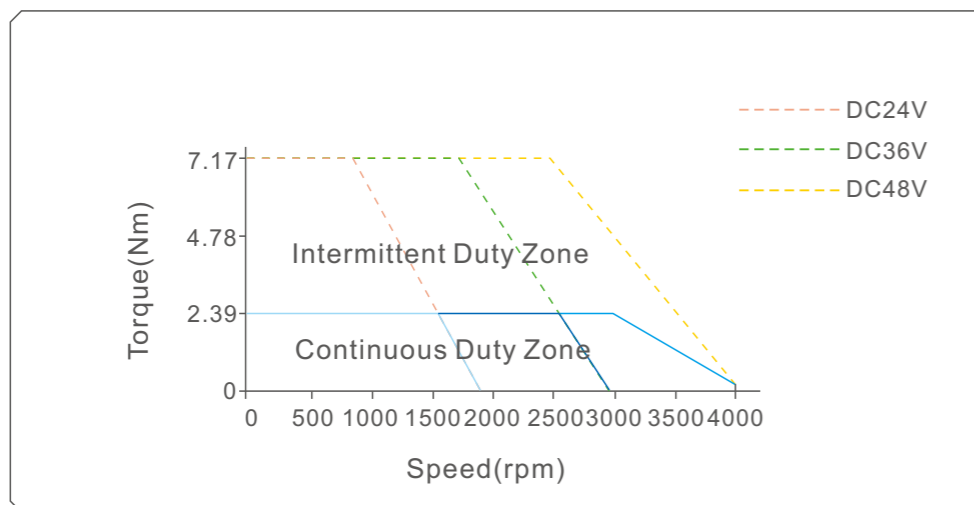

Drive Connections

- iSV2-RS

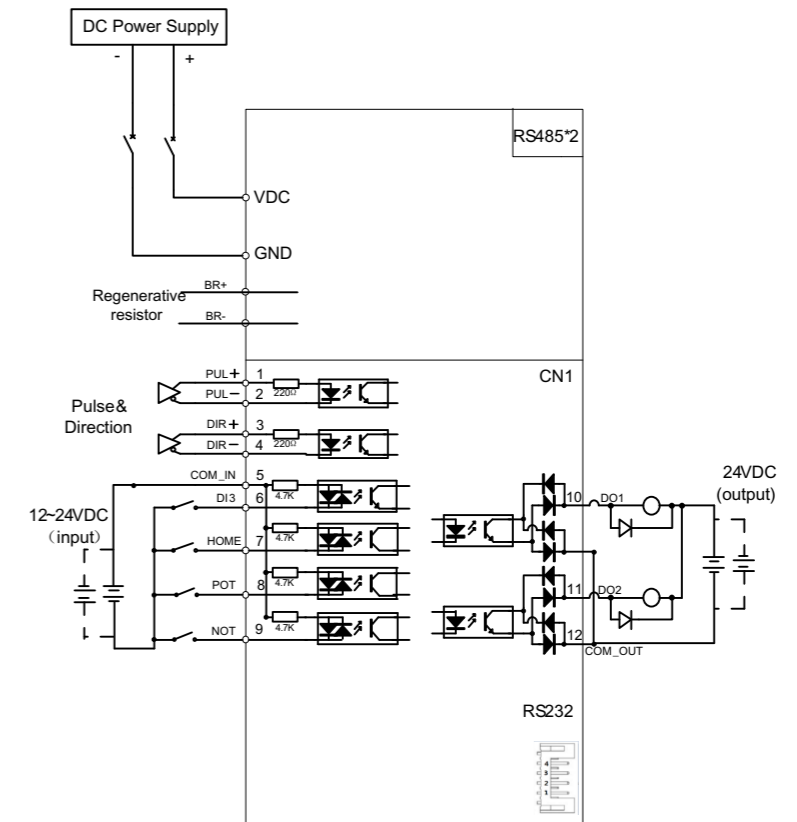

- iSV2-CAN

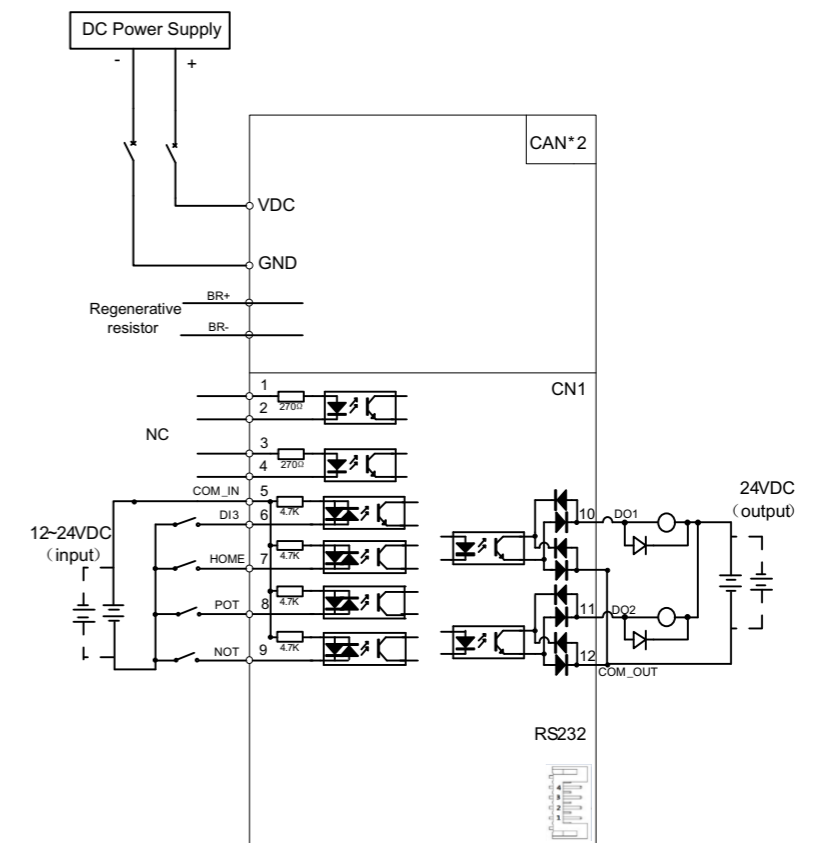

Integrated Servo Motors

iSV Series

- Highly Integrated, Servo motor + advanced DSP servo drive
- Lower cable cost
- Support step & direction, commands
- Built-in pulse generator for the tuning and self-test
- Compact size, Save mounting space



Leadshine's iSV series integrated servo motors are one of the most compact servo systems available on the market. An iSV integrated servo has a servo motor (PMSM or BLDC optional) and an advanced DSP servo drive. At very compact size and with all components integrated, the iSV series servos can save mounting space, eliminate encoder connection and motor wiring time, increase reliability, and lower cable and labor cost. The drive takes step & direction, commands, and is capable of outputting in position and fault signals back to the master controller or external devices for complete system controls.

Part Numbers

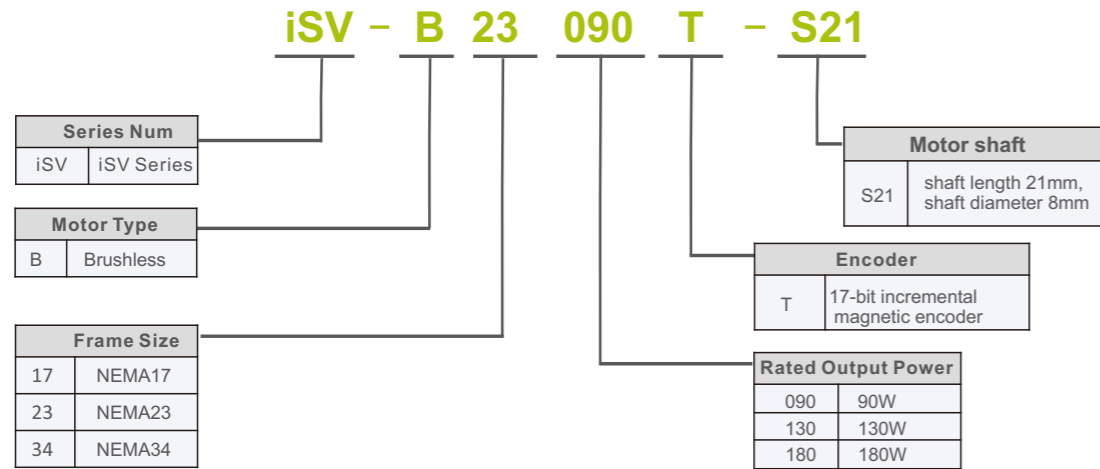

Specifications

Part Number	iSV-B23090T-S21	iSV-B23130T-S21	iSV-B23180T-S21
Rated Power(W)	90	130	180
Rated Torque(Nm)	0.30	0.45	0.6
Peak Torque(Nm)	0.80	1.1	1.1
Rated Speed(rpm)	3000	3000	3000
PeakSpeed(rpm)	4000	4000	4000
Rated Voltage(VDC)	36	36	36
Weight(kg)	0.95	1.25	1.54

Dimensions

- iSV-B23090T-S21 Units: mm 1 inch = 25.4 mm

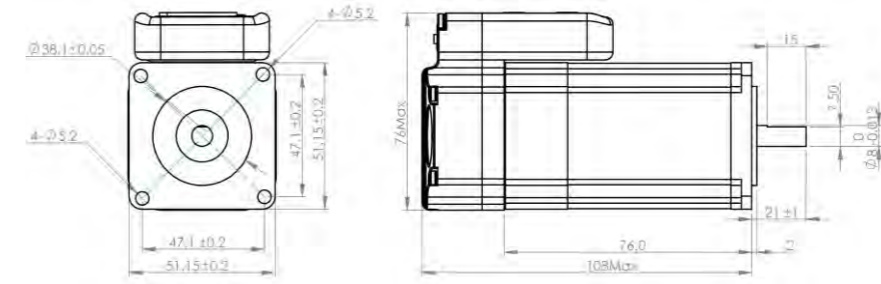

- iSV-B23130T-S21

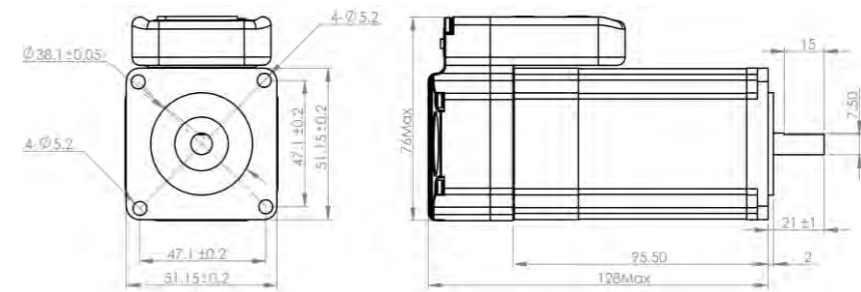

- iSV-B23180T-S21

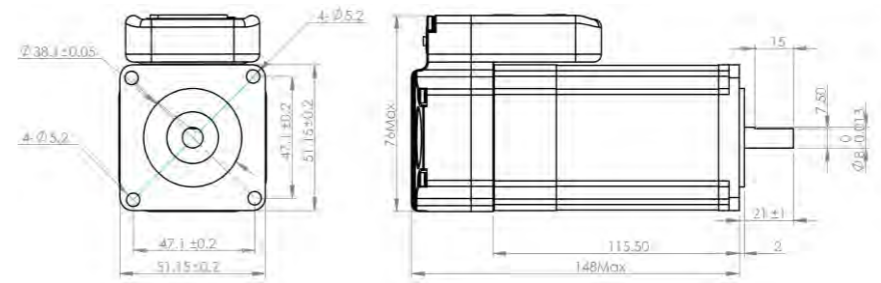

Power Supplies

- 220VAC \pm 10% or 110 VAC \pm 10%
- Higher Reliability and mass production
- High efficiency, low temperature rising



Features

- 1.8 or 3 times overload
- Compact Size, Light in Weight
- Use Switch to select input voltage 220VAC \pm 10%
- Over-current, Over-voltage, Low-voltage Protections
- Big Power with High Efficiency
- CE and RoHS

Electrical Specifications

Model	Output Voltage (VDC)	Continuous Current(Arms)	Peak Current(Arms)	Input Voltage	Power(W)	Dimensions (mm)	Weight(kg)
SPS2410(V3.0)	24	10	30	220VAC \pm 10%	240	199*110*50	0.8
SPS3611(V3.0)	36	11	33		400	215*115*30	0.6
SPS488(V3.0)	48	8.3	24.9		400	215*115*30	0.6
SPS606(V3.0)	60	6.7	20.1		400	215*115*30	0.6

Dimensions

(unit: mm, 1inch=25.4mm)

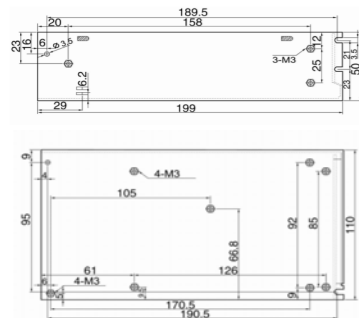

SPS2410(V2.0)

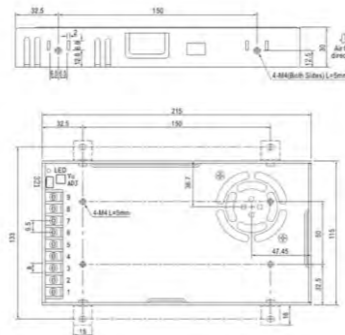

SPS3611(V2.0)/SPS488(V2.0)/SPS607(V2.0)