

**APEX DYNAMICS, INC.**

**NEW GENERATION  
PLANETARY GEARBOX**

**AH / AHK Series**

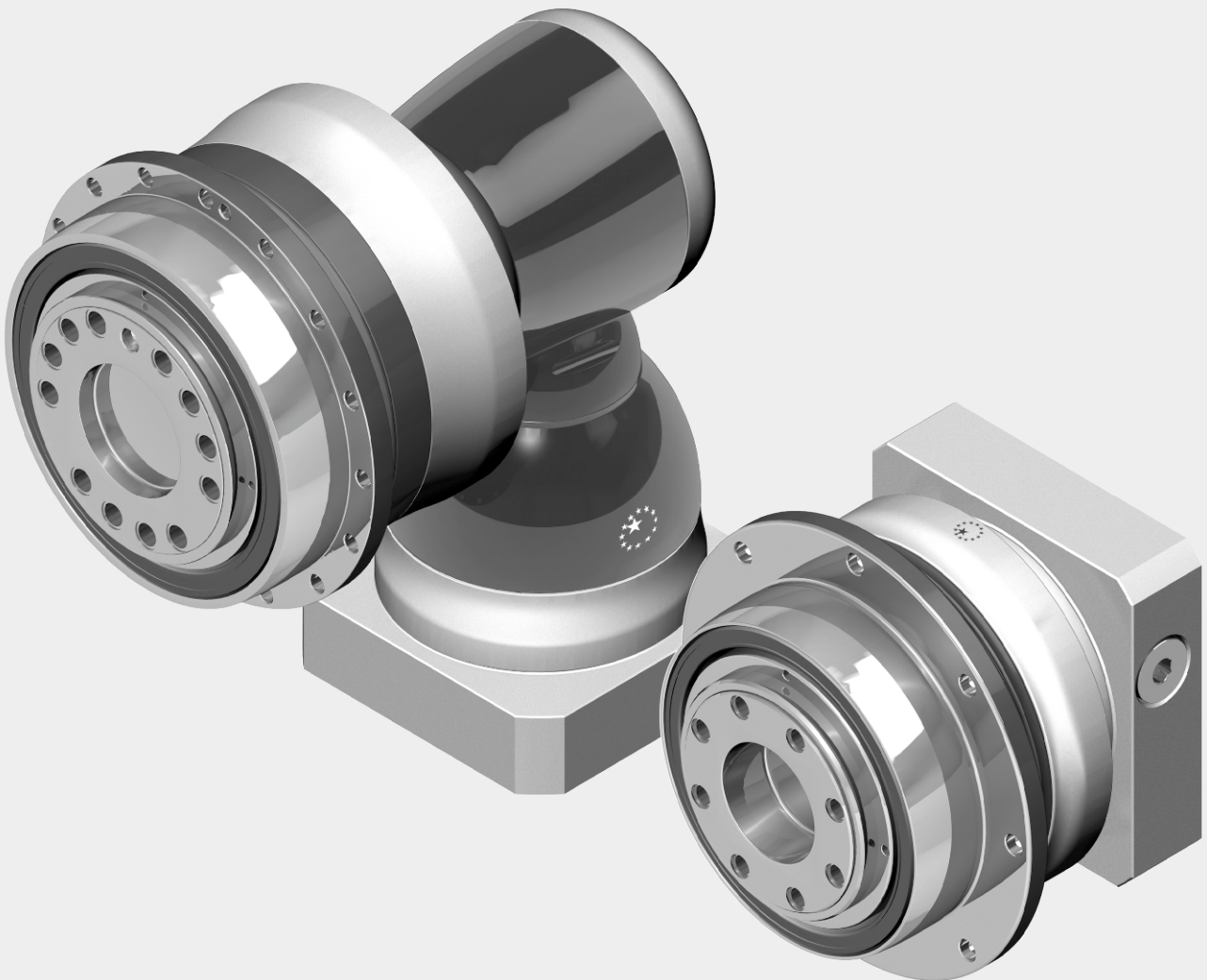

## Gearbox Series - AH / AHK

### ► Features:

- High Torque
- High efficiency
- Long-Term persistence of reduced backlash
- Low noise
- Long service life
- Limited temperature rise
- Optimized output torque
- Optimized Inertia moment
- Flexible mounting diameters

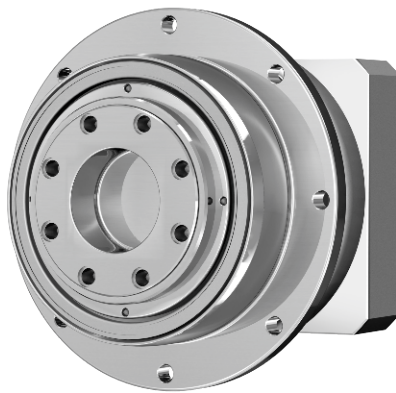

# Ordering Code - AH / AHK Gearbox

<b>AH090</b>	—	<b>005<sup>(1)</sup></b>	/	<b>MOTOR</b>
<b>AHS090</b>	—	<b>005<sup>(1)</sup></b>		
<b>AHK090</b>	—	<b>005<sup>(1)</sup></b>	/	<b>MOTOR</b>
<b>AHKA285<sup>(3)</sup></b>				<b>Motor Type</b>
<b>AHKB090<sup>(3)</sup></b>				<b>Ratio</b>
				<b>Gearbox Size</b>

**AHS is the AH version with input “SHAFT” instead of input “HUB”<sup>(4)</sup>**

### Gearbox Size

**AH 064 / 090 / 110 / 140 / 200 / 255 / 285 / 355 / 450**  
**AHK 064 / 090 / 110 / 140 / 200 / 255 / 285 / 355 / 450**

### Ratio<sup>(2)</sup>

**AH 4 / 5 / 7 / 10**  
**16 / 20 / 21 / 25 / 28 / 31 / 35 / 40 / 46 / 50 / 61 / 70 / 91 / 100**  
**AHK (2 Stg.) 12 / 15 / 16 / 20 / 25 / 28 / 35 / 40 / 49 / 50 / 70 / 100**  
**AHKA (3 Stg.) 100 / 125 / 140 / 175 / 200 / 250 / 350 / 500 / 700 / 1,000**  
**AHKB (3 Stg.) 64 / 84 / 100 / 125 / 140 / 175 / 200 / 250 / 280 / 350 / 400 / 500 / 700 / 1,000**  
**AHK (4 Stg.) 1,225 / 1,400 / 1,750 / 2,000 / 2,800 / 3,500 / 5,000 / 7,000 / 10,000**  
**AHKC 4 / 5 / 7 / 8 / 10 / 21 / 31 / 46 / 61 / 91**

### Motor Type

### Manufacturer and Model

(1) Ratio (I=N<sub>in</sub>/N<sub>out</sub>).

(2) Please refer to the specifications for the ratios provided in each series.

(3) Please refer to page 06.

(4) The customization detail please contact with APEX sales.



# Performance - AH Gearbox

Model No.	Stage	Ratio <sup>(1)</sup>	AH064	AH090	AH110	AH140	AH200	AH255	AH285	AH355	AH450	
Nominal Output Torque $T_{2N}$	1	4	95	195	350	600	1,290	-	-	-	-	
		5	80	165	305	525	1,145	1,745	3,285	5,595	10,915	
		7	60	130	250	435	980	1,495	2,525	4,820	9,585	
		10	24	55	160	305	700	1,070	1,810	3,345	7,160	
	2	16	95	195	360	615	1,320	-	-	-	-	
		20	95	200	360	615	1,320	1,770	3,325	-	-	
		21	80	165	310	535	1,165	1,770	3,330	5,595	10,915	
		25	80	165	310	535	1,165	1,770	3,330	-	-	
		28	60	200	360	615	1,325	-	-	-	-	
		31	60	130	250	440	990	1,510	2,550	4,810	9,565	
		35	70	170	310	535	1,165	1,775	3,335	-	-	
		40	40	96	220	615	1,215	-	-	-	-	
		46	24	55	160	295	660	1,005	1,700	3,400	7,125	
		50	50	120	275	535	1,170	1,775	3,340	-	-	
		61	60	130	250	440	990	1,510	2,550	4,820	9,585	
		70	60	130	250	440	990	1,510	2,550	-	-	
		91	24	55	160	295	660	1,005	1,700	3,345	7,000	
		100	24	55	160	295	660	1,005	1,700	-	-	
Emergency Stop Torque $T_{2NOT}$	Nm	1,2	4~100	3 times $T_{2N}$								
Max. Acceleration Torque $T_{2B}$	Nm	1,2	4~100	1.5 times $T_{2N}$								
No Load Running Torque <sup>(3)</sup>	Nm	1	4~10	0.45	0.7	1.4	3.5	7	11	14	25	40
		2	16~100	0.2	0.3	0.6	1.3	2.2	3.5	4.5	13	21
Backlash <sup>(2)</sup>	arcmin	1	4~10	≤ 2	≤ 1	≤ 1	≤ 1	≤ 1	≤ 1	≤ 1	≤ 1	≤ 1
		2	16~100	≤ 3	≤ 2	≤ 2	≤ 2	≤ 2	≤ 2	≤ 2	≤ 2	≤ 2
Torsional Rigidity	Nm/arcmin	1,2	4~100	8	22	60	115	395	650	1,050	2,850	5,700
Nominal Input Speed $n_{1N}$	rpm	1	4~10	5,000	3,600	3,600	3,000	2,700	2,400	2,100	1,500	1,000
		2	16~100	5,000	4,600	4,600	4,000	3,700	3,400	3,100	2,500	2,000
Max. Input Speed $n_{1B}$	rpm	1	4~10	7,000	6,000	6,000	5,000	4,500	4,000	3,500	3,000	2,500
		2	16~100	7,000	7,000	7,000	6,000	5,500	5,000	4,500	4,000	3,500
Max. Axial Load $F_{2a}$ <sup>(4)</sup>	N	1,2	4~100	1,690	2,220	4,070	8,530	17,000	26,900	39,200	101,500	143,700
Max. Tilting Moment $M_{2K}$ <sup>(4)</sup>	Nm	1,2	4~100	120	280	480	1,310	3,530	5,920	9,230	29,100	63,300
Operating Temp	°C	1,2	4~100	-10° C ~ 90° C								
Degree of Gearbox Protection		1,2	4~100	IP67								
Lubrication		1,2	4~100	Synthetic lubrication grease								
Mounting Position		1,2	4~100	All directions								
Running Noise <sup>(3)</sup>	dB(A)	1	4~10	≤ 58	≤ 59	≤ 64	≤ 65	≤ 66	≤ 66	≤ 66	≤ 68	≤ 70
		2	16~100	≤ 58	≤ 59	≤ 60	≤ 63	≤ 66	≤ 66	≤ 66	≤ 68	≤ 70
Efficiency $\eta$	%	1	4~10	≥ 97%								
		2	16~100	≥ 94%								

(1) Ratio ( $i = N_{in} / N_{out}$ ).

(2) Backlash is measured at 2% of Nominal Output Torque  $T_{2N}$ .

(3) The dB values are measured by gearbox with ratio 10 (1-stage) or ratio 100 (2-stage), no loading at 3,000 RPM or at the respective Nominal Input Speed by bigger model size.

By lower ratio and/or higher RPM, the noise level could be 3 to 5 dB higher.

(4) Applied to the output flange center at 100 rpm.

(5) Continuous operation is not recommended.

# Inertia - AH Gearbox

Model No.	AH064		AH090		AH110		AH140		AH200		AH255		AH285		AH355		AH450	
	∅ <sup>(A)</sup> (C3)		1-st.	2-st.	1-st.	2-st.	1-st.	2-st.	1-st.	2-st.	1-st.	2-st.	1-st.	2-st.	1-st.	2-st.	1-st. <sup>(B)</sup>	2-st. <sup>(B)</sup>
8	kg.cm <sup>2</sup>		-	0.1	-	-	-	-	-	-	-	-	-	-	-	-	-	-
11			0.17	0.16	-	0.17	-	-	-	-	-	-	-	-	-	-	-	-
14			0.21	0.2	0.53	0.21	-	0.53	-	-	-	-	-	-	-	-	-	-
19			0.63	-	0.68	0.63	1.83	0.68	-	1.83	-	-	-	-	-	-	-	-
24			-	-	4.52	-	5.04	4.52	5.63	5.04	-	5.63	-	-	-	-	-	-
28			-	-	-	-	6.33	-	7.18	6.33	-	7.18	-	-	-	-	-	-
32			-	-	-	-	8.73	-	10.1	8.73	12.63	10.1	-	12.63	-	-	-	-
35			-	-	-	-	14.04	-	15.54	14.04	17.75	15.54	17.35	17.75	28.18	20.8	-	-
38			-	-	-	-	19.05	-	21.32	19.05	23.26	21.32	23.61	23.26	28.18	27.05	-	23.6
42			-	-	-	-	-	-	23.2	-	25.4	23.2	25.5	25.4	30.52	28.95	-	25.37
48			-	-	-	-	-	-	56.07	-	61.02	56.07	61.22	61.02	66.85	64.66	-	89.35
55			-	-	-	-	-	-	-	-	88.51	-	88.86	-	94.91	-	-	102
60			-	-	-	-	-	-	-	-	-	-	-	117.73	-	-	-	117.75

(A) ∅ = Input shaft diameter.

(B) For 1-st. of AH355/AH450 please contact APEX for details.

## Flange Shaft - AH

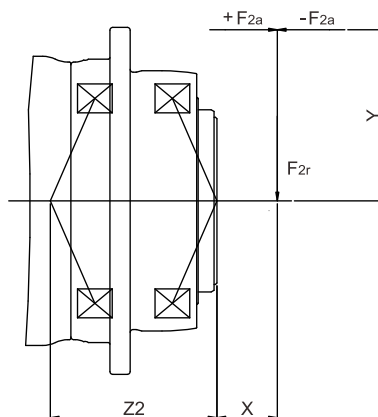
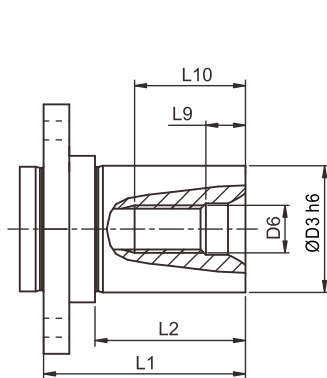

$$M_{2K} = \frac{F_{2a} * Y + F_{2r} * (X + Z_2)}{1000}$$

M<sub>2K</sub> : [Nm]

F<sub>2a</sub>, F<sub>2r</sub> : [N]

X, Y, Z<sub>2</sub> : [mm]

Dimension	L1	L2	D3 h6	D6	L9	L10	Order Code
AH064	33	23	16	M5	4.8	12.5	FLS-AH064-S16
			22	M8	7.2	19	FLS-AH064-S22
AH090	41	30	22	M8	7.2	19	FLS-AH090-S22
			32	M12	10	28	FLS-AH090-S32
AH110	51	38	32	M12	10	28	FLS-AH110-S32
			40	M16	12	36	FLS-AH110-S40
AH140	54	38	40	M16	12	36	FLS-AH140-S40
			55	M20	15	42	FLS-AH140-S55
AH200	73	52	55	M20	15	42	FLS-AH200-S55
			75	M20	15	42	FLS-AH200-S75
AH255	150	123	90	M24	18	50	FLS-AH255-S90

Note: Dimensions are related to gearbox flange interface.

### M2K

AH / AHK	064	090	110	140	200	255	285	355	450
Z <sub>2</sub> [mm]	63.7	84.5	106.2	90	122.8	133.2	175.5	220.6	275.3

Note : Applied to the output flange center at 100 rpm

# Dimension AH Gearbox

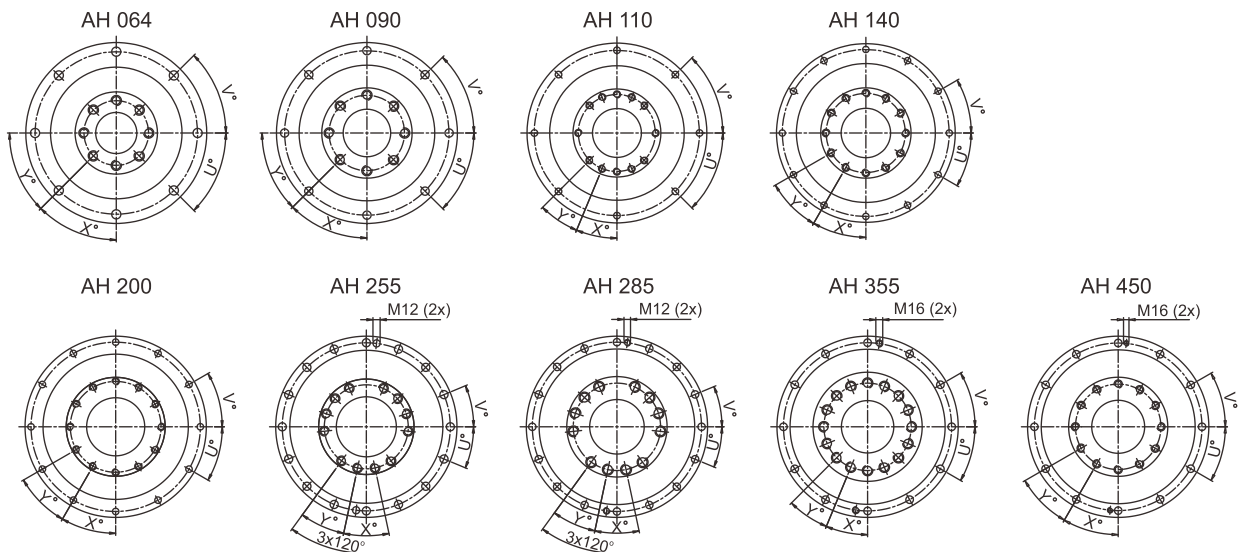
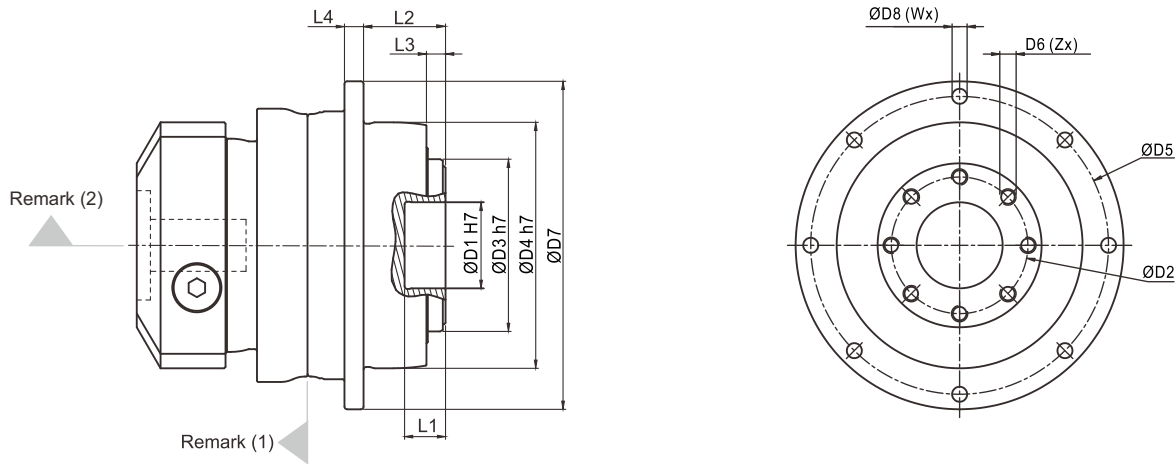

Dimension	AH064	AH090	AH110	AH140	AH200	AH255	AH285	AH355	AH450
D1 H7	20	31.5	40	50	80	100	100	120	155
D2	31.5	50	63	80	125	140	160	200	250
D3 h7	40	63	80	100	160	180	200	250	315
D4 h7	64	90	110	140	200	255	285	355	450
D5	79	109	135	168	233	280	310	385	490
D6 x Pitch x Deep	M5x0.8Px8	M6x1Px10	M6x1Px11	M8x1.25Px15	M10x1.5Px20	M16x2Px25	M20x2.5Px31	M24x3Px32	M30x3.5Px40
D7	88	120	147	180	249.5	302	332	415	530
D8	4.5	5.5	5.5	6.6	9	13.5	13.5	17.5	22
L1	8	15	15	15	16	16	16	35	24
L2	19.5	30	29	38	50	66	75	80	85
L3	4	7	7	7.5	8.5	13.5	16.5	20	20
L4	5	7	8	10	12	18	20	45	60
X in Degree	45	45	22.5	30	30	24	24	22.5	30
Y in Degree	45	45	22.5	30	30	24	24	22.5	30
Z	8	8	12	12	12	12	12	16	12
U in Degree	45	45	45	30	30	22.5	22.5	30	30
V in Degree	45	45	45	30	30	22.5	22.5	30	30
W	8	8	8	12	12	16	16	12	12

(1) Dimensions are related to motor interface. Please contact APEX for details.

(2) As alternative to input "HUB", input "SHAFT" is also available, please find in page 06.

# Dimension - AHS (Input Shaft as Option)

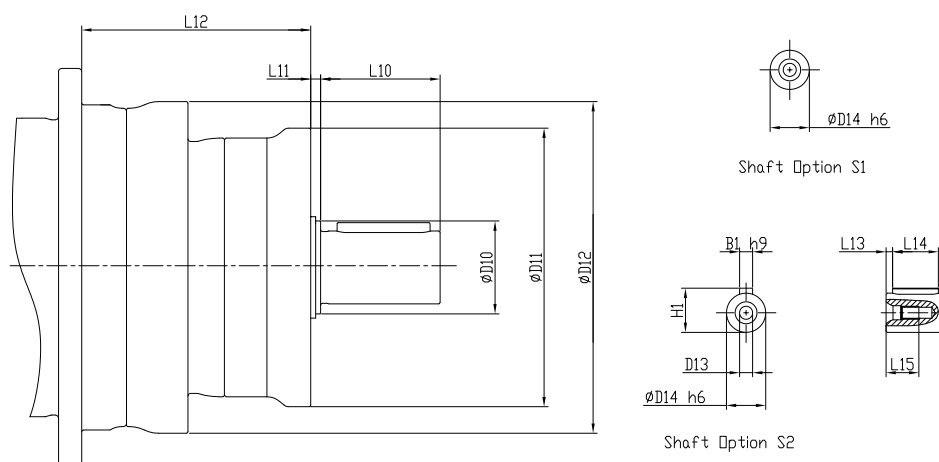

Dimension	Stage	AHS064	AHS090	AHS100	AHS140	AHS200	AHS255	AHS285	AHS355	AHS450
D10	1	20	28	35	50	70	70	75	-	-
	2	17	20	28	35	50	70	70	75	75
D11	1	68	84	93	118	178	180	225	-	-
	2	60	68	84	93	118	178	180	225	225
D12	1,2	76	100	132	160	232	262	301.5	362	466
D13	1	M4x0.7P	M8x1.25P	M10x1.5P	M12x1.75P	M16x2P	M20x2.5P	M20x2.5P	-	-
	2	M3x0.5P	M4x0.7P	M8x1.25P	M10x1.5P	M12x1.75P	M16x2P	M20x2.5P	M20x2.5P	M20x2.5P
D14 h6	1	12	22	28	38	45	55	60	-	-
	2	10	12	22	28	38	45	55	55	60
L10	1	18	36	42	58	82	82	105	-	-
	2	15	18	36	42	58	82	82	82	105
L11	1	3	3	4	5	10	11	11	-	-
	2	3	3	3	4	5	10	11	11	11
L12	1	57.5	69	88	107.5	151.5	149	216	-	-
	2	73	85	110	136	174.5	210	255.5	278.5	374
L13	1	2	3	5	5	5	6	2.5	-	-
	2	2	2	3	5	5	5	6	6	2.5
L14	1	14	28	32	40	65	70	100	-	-
	2	10	14	28	32	40	65	70	70	100
L15	1	10	19	22	28	36	42	42	-	-
	2	9	10	19	22	28	36	42	42	42
B1 h9	1	4	6	8	10	14	16	18	-	-
	2	3	4	6	8	10	14	16	16	18
H1	1	13.5	24.5	31	41	48.5	59	64	-	-
	2	11.2	13.5	24.5	31	41	48.5	59	59	64

# Performance - AHS (Input Shaft as Option)

Model No.		Stage	Ratio <sup>(1)</sup>	AHS064	AHS090	AHS110	AHS140	AHS200	AHS255	AHS285	AHS355	AHS450
Max. Radial Load $F_{1rB}$ <sup>(2)</sup>	N	1	4~10	460	600	800	1,025	2,720	2,940	3,620	-	-
		2	16~100	275	460	600	800	1,025	2,720	2,940	3,240	3,620
Max. Axial Load $F_{1aB}$ <sup>(2)</sup>	N	1	4~10	230	300	400	512	1,360	1,470	1,810	-	-
		2	16~100	137	230	300	400	512	1,360	1,470	1,620	1,810
Moment of Inertia	Kg·cm <sup>2</sup>	1	4~10	0.19	0.62	1.78	7.72	44.73	55.41	133.12	-	-
		2	16~100	0.06	0.19	0.62	1.78	7.72	44.73	53.41	133.12	111.15

(1) Ratio ( $i = N_{in} / N_{out}$ ).

(2) Applied to the input shaft center at 1000 rpm

(3) The customization detail please contact with APEX sales.

# AHK Gearbox

## AHK Structure

(I)

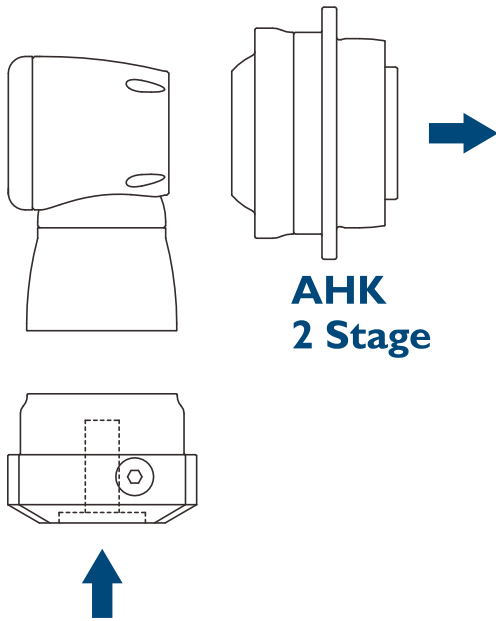

(II)

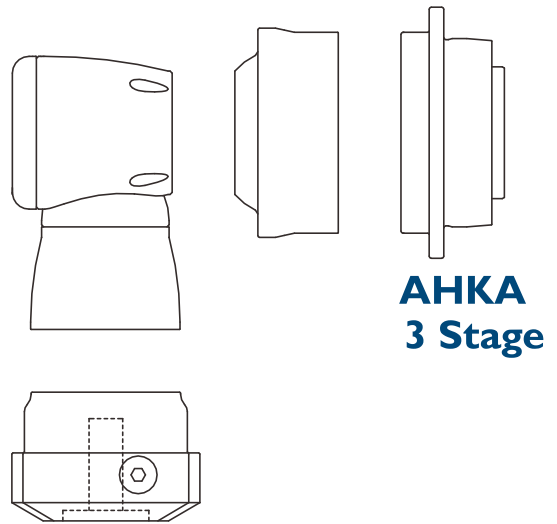

(III)

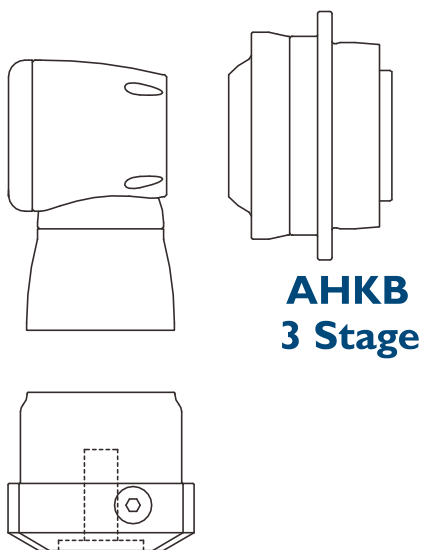

(IV)

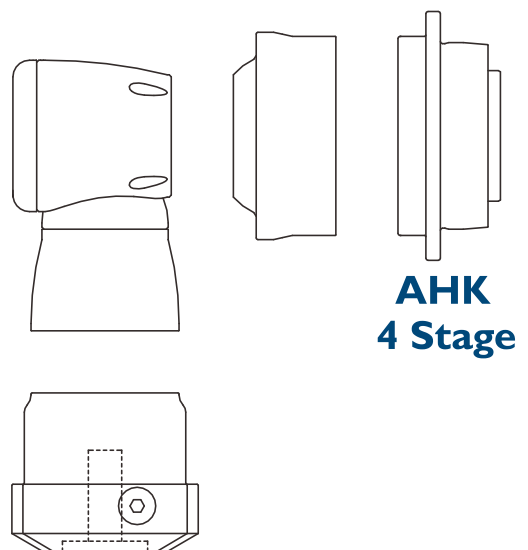



# Performance - AHK ( 2 Stage ) Gearbox

Model No.	Stage	Ratio <sup>(1)</sup>	AHK064	AHK090	AHK110	AHK140	AHK200	AHK255	AHK285	AHK355	
Nominal Output Torque T <sub>2N</sub>	Nm	2	12	95	195	360	615	1,315	-	-	-
			15	-	-	-	-	-	1,770	3,330	5,595
			16	95	200	360	615	1,320	-	-	-
			20	95	200	360	615	1,320	1,775	3,335	5,605
			25	80	170	310	535	1,165	1,775	3,335	5,610
			28	92	200	360	615	1,325	-	-	-
			35	80	170	310	535	1,170	1,775	3,340	5,615
			40	60	160	340	615	1,325	-	-	-
			49	60	130	250	440	990	1,510	2,550	4,820
			50	50	170	310	535	1,170	1,775	3,000	5,500
70	60	130	250	440	990	1,510	2,550	4,820			
100	24	55	160	290	655	1,005	1,685	3,315			
Emergency Stop Torque T <sub>2NOT</sub>	Nm	2	12~100	2 times T <sub>2N</sub>							
Max. Acceleration Torque T <sub>2B</sub>	Nm	2	12~100	1.5 times T <sub>2N</sub>							
No Load Running Torque <sup>(3)</sup>	Nm	2	12~100	1	1.3	2	3.1	6	13	16	20
Backlash <sup>(2)</sup>	arcmin	2	12~100	≤ 3	≤ 2	≤ 2	≤ 2	≤ 2	≤ 2	≤ 2	≤ 2
Torsional Rigidity	Nm/arcmin	2	12~100	12	27	56	112	389	642	1,275	2,500
Nominal Input Speed n <sub>IN</sub>	rpm	2	12~100	3,000	3,000	2,800	2,700	2,200	2,100	2,000	1,600
Max. Input Speed n <sub>IB</sub>	rpm	2	12~100	6,000	6,000	6,000	4,500	4,500	4,000	3,000	2,500
Max. Axial Load F <sub>2a</sub> <sup>(4)</sup>	N	2	12~100	1,690	2,220	4,070	8,530	17,000	26,900	39,200	101,500
Max. Tilting Moment M <sub>2k</sub> <sup>(4)</sup>	Nm	2	12~100	120	280	480	1,310	3,530	5,920	9,230	29,100
Operating Temp	°C	2	12~100	-10° C ~ 90° C							
Degree of Gearbox Protection		2	12~100	IP67							
Lubrication		2	12~100	Synthetic lubrication grease							
Mounting Position		2	12~100	All directions							
Running Noise <sup>(3)</sup>	dB(A)	2	12~100	≤ 64	≤ 66	≤ 68	≤ 68	≤ 70	≤ 70	≤ 72	≤ 74
Efficiency η	%	2	12~100	≥ 94%							

(1) Ratio ( i = N<sub>in</sub> / N<sub>out</sub> ) .

(2) Backlash is measured at 2% of Nominal Output Torque T<sub>2N</sub> .

(3) The dB values are measured by gearbox with ratio 100 (2-stage), no loading at 3,000 RPM or at the respective Nominal Input Speed by bigger model size.

By lower ratio and/or higher RPM, the noise level could be 3 to 5 dB higher.

(4) Applied to the output flange center at 100 rpm.

(5) Continuous operation is not recommended.

# Inertia - AHK ( 2 Stage ) Gearbox

Model No.	AHK064	AHK090	AHK110	AHK140	AHK200	AHK255	AHK285	AHK355
8	0.1	-	-	-	-	-	-	-
11	0.17	0.18	-	-	-	-	-	-
14	0.21	0.5	0.52	-	-	-	-	-
19	-	0.65	1.69	1.71	-	-	-	-
24	-	-	4.89	5.05	6.92	-	-	-
28	-	-	-	6.55	6.98	-	-	-
32	-	-	-	9.47	10.18	10.18	-	-
35	-	-	-	14.91	15.21	15.21	15.68	-
38	-	-	-	20.69	20.7	20.7	21.69	23.46
42	-	-	-	-	22.83	22.83	23.59	25.28
48	-	-	-	-	58.45	58.45	59.3	61.61
55	-	-	-	-	-	-	-	89.67

(A) Ø = Input shaft diameter.

# Dimension AHK ( 2 stage ) Gearbox ( Ratio i=12~100 )

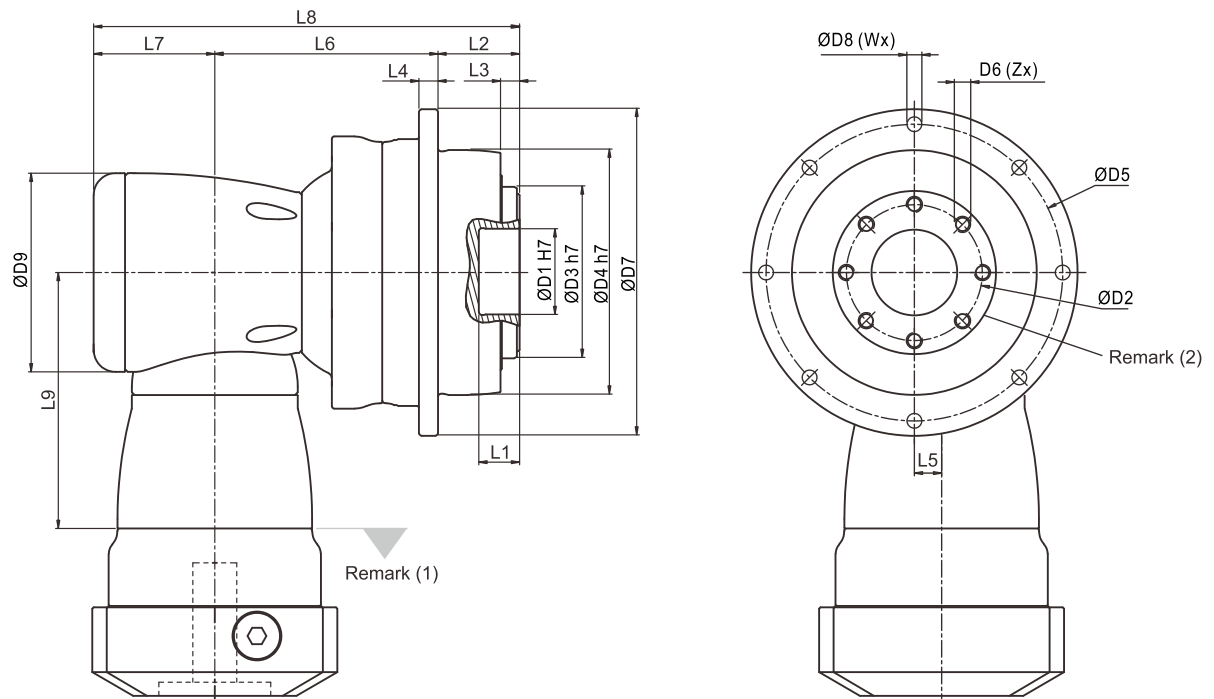

Dimension	AHK064	AHK090	AHK110	AHK140	AHK200	AHK255	AHK285	AHK355
D1 H7	20	31.5	40	50	80	100	100	120
D2	31.5	50	63	80	125	140	160	200
D3 h7	40	63	80	100	160	180	200	250
D4 h7	64	90	110	140	200	255	285	355
D5	79	109	135	168	233	280	310	385
D6 x Pitch x Deep	M5x0.8Px8	M6x1Px10	M6x1Px11	M8x1.25Px15	M10x1.5Px20	M16x2Px25	M20x2.5Px31	M24x3Px32
D7	88	120	147	180	249.5	302	332	415
D8	4.5	5.5	5.5	6.6	9	13.5	13.5	17.5
D9	73	94	116	163	210	210	255	300
L1	8	15	15	15	16	16	16	35
L2	19.5	30	29	38	50	66	75	80
L3	4	7	7	7.5	8.5	13.5	16.5	20
L4	5	7	8	10	12	18	20	45
L5	10	13	17	25	31	31	36	43
L6	87	90.5	114	147.5	175	191.5	249.5	290
L7	44.5	53	68.3	89	115	115	131	165
L8	151	173.5	211.3	274.5	340	372.5	455.5	535
L9	94	114.5	129	173.5	228	228	265.5	294.5
X in Degree	45	45	22.5	30	30	24	24	22.5
Y in Degree	45	45	22.5	30	30	24	24	22.5
Z	8	8	12	12	12	12	12	16
U in Degree	45	45	45	30	30	22.5	22.5	30
V in Degree	45	45	45	30	30	22.5	22.5	30
W	8	8	8	12	12	16	16	12

(1) Dimensions are related to motor interface. Please contact APEX for details.

(2) Refer to the AH series (Page 05) for flange interface.

# Performance - AHKA ( 3 stage ) Gearbox

Model No.	Stage	Ratio <sup>(1)</sup>	AHKA285	AHKA355	AHKA450	
Nominal Output Torque $T_{2N}$	Nm	3	100	3,345	5,620	10,965
			125	3,345	5,625	10,970
			140	3,345	5,625	10,970
			175	3,345	5,625	10,970
			200	3,345	5,625	10,975
			250	3,345	5,625	10,975
			350	3,345	5,630	10,975
			500	3,345	5,350	9,050
			700	2,555	4,825	9,600
		1,000	1,650	3,250	6,785	
Emergency Stop Torque $T_{2NOT}$	Nm	3	100~1,000	2 times $T_{2N}$		
Max. Acceleration Torque $T_{2B}$	Nm	3	100~1,000	1.5 times $T_{2N}$		
No Load Running Torque <sup>(3)</sup>	Nm	3	100~1,000	6	13	
Backlash <sup>(2)</sup>	arcmin	3	100~1,000	$\leq 2$	$\leq 2$	
Torsional Rigidity	Nm/arcmin	3	100~1,000	1,275	5,100	
Nominal Input Speed $n_{1N}$	rpm	3	100~1,000	2,100	2,000	
Max. Input Speed $n_{1B}$	rpm	3	100~1,000	4,000	3,000	
Max. Axial Load $F_{2a}$ <sup>(4)</sup>	N	3	100~1,000	39,200	143,700	
Max. Tilting Moment $M_{2K}$ <sup>(4)</sup>	Nm	3	100~1,000	9,230	63,300	
Operating Temp	°C	3	100~1,000	-10° C ~ 90° C		
Degree of Gearbox Protection		3	100~1,000	IP65		
Lubrication		3	100~1,000	Synthetic lubrication grease		
Mounting Position		3	100~1,000	All directions		
Running Noise <sup>(3)</sup>	dB(A)	3	100~1,000	$\leq 72$	$\leq 76$	
Efficiency $\eta$	%	3	100~1,000	$\geq 92\%$		

(1) Ratio ( $i = N_{in} / N_{out}$ ).

(2) Backlash is measured at 2% of Nominal Output Torque  $T_{2N}$ .

(3) The dB values are measured by gearbox with ratio 1,000 (3-stage), no loading at 3,000 RPM or at the respective Nominal Input Speed by bigger model size.

By lower ratio and/or higher RPM, the noise level could be 3 to 5 dB higher.

(4) Applied to the output flange center at 100 rpm.

(5) Continuous operation is not recommended.

## Inertia - AHKA ( 3 stage ) Gearbox

Model No.	AHKA285	AHKA355	AHKA450
Input Shaft (C3) $\varnothing^{(A)}$			
32	10.18	10.18	-
35	15.21	15.21	15.68
38	20.7	20.7	21.69
42	22.83	22.83	23.59
48	58.45	58.45	59.3
55	-	-	86.95

(A)  $\varnothing$  = Input shaft diameter.

# Dimension AHKA ( 3 Stage ) Gearbox ( Ratio $i = 100 \sim 1,000$ )

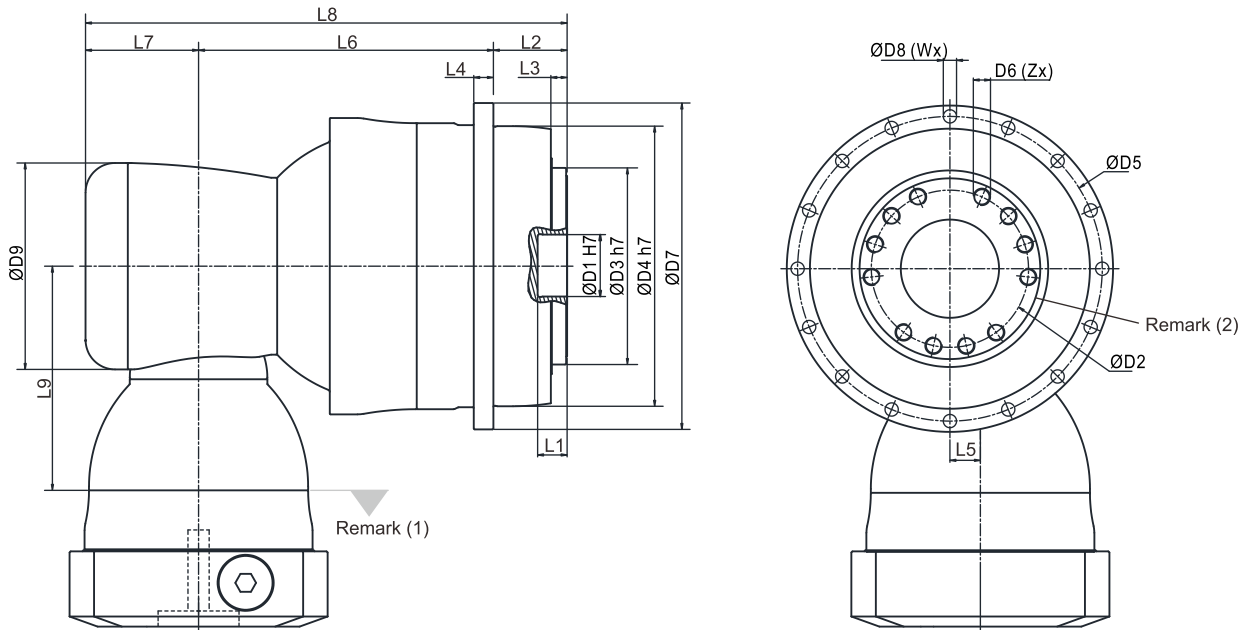

Dimension		AHKA285	AHKA355	AHKA450
D1	H7	100	120	155
D2		160	200	250
D3	h7	200	250	315
D4	h7	285	355	450
D5		310	385	490
D6 x Pitch x Deep		M20x2.5Px31	M24x3Px32	M30x3.5Px40
D7		332	415	530
D8		13.5	17.5	22
D9		210	210	255
L1		16	35	24
L2		75	80	85
L3		16.5	20	20
L4		20	45	60
L5		31	31	36
L6		300	332	447.5
L7		115	115	131
L8		490	527	663.5
L9		228	228	265.5
X in Degree		24	22.5	30
Y in Degree		24	22.5	30
Z		12	16	12
U in Degree		22.5	30	30
V in Degree		22.5	30	30
W		16	12	12

(1) Dimensions are related to motor interface. Please contact APEX for details.

(2) Refer to the AH series (Page 05) for flange interface.

# Performance - AHKB ( 3 stage ) Gearbox

Model No.	Stage	Ratio <sup>(1)</sup>	AHKB090	AHKB110	AHKB140	AHKB200	AHKB255	AHKB285	AHKB355	
Nominal Output Torque $T_{2N}$	Nm	3	64	200	360	615	1,325	-	-	-
			84	200	360	620	1,325	-	-	-
			100	200	360	620	1,330	1,780	3,345	5,620
			125	170	310	535	1,170	1,780	3,345	5,625
			140	200	360	620	1,330	1,780	3,345	5,625
			175	170	310	535	1,170	1,780	3,345	5,625
			200	200	360	620	1,330	1,780	3,345	5,625
			250	170	310	535	1,170	1,780	3,345	5,625
			280	200	360	620	1,330	1,510	-	-
			350	170	310	535	1,170	1,775	3,345	5,630
			400	160	340	620	1,330	-	-	-
			500	170	310	535	1,170	1,780	3,000	5,500
			700	130	250	440	990	1,510	2,555	4,825
			1,000	55	160	290	640	980	1,655	3,250
Emergency Stop Torque $T_{2NOT}$	Nm	3	64~1,000	2 times $T_{2N}$						
Max. Acceleration Torque $T_{2B}$	Nm	3	64~1,000	1.5 times $T_{2N}$						
No Load Running Torque <sup>(3)</sup>	Nm	3	64~1,000	0.2	0.2	0.3	0.4	1	1.2	1.5
Backlash <sup>(2)</sup>	arcmin	3	64~1,000	≤ 2	≤ 2	≤ 2	≤ 2	≤ 2	≤ 2	≤ 2
Torsional Rigidity	Nm/arcmin	3	64~1,000	27	56	112	389	642	1,275	2,500
Nominal Input Speed $n_{1N}$	rpm	3	64~1,000	5,500	4,600	4,600	4,000	3,700	3,400	3,100
Max. Input Speed $n_{1B}$	rpm	3	64~1,000	7,000	7,000	7,000	6,000	5,500	5,000	4,500
Max. Axial Load $F_{2a}$ <sup>(4)</sup>	N	3	64~1,000	2,220	4,070	8,530	17,000	26,900	39,200	101,500
Max. Tilting Moment $M_{2K}$ <sup>(4)</sup>	Nm	3	64~1,000	280	480	1,310	3,530	5,920	9,230	29,100
Operating Temp	°C	3	64~1,000	-10° C ~ 90° C						
Degree of Gearbox Protection		3	64~1,000	IP65						
Lubrication		3	64~1,000	Synthetic lubrication grease						
Mounting Position		3	64~1,000	All directions						
Running Noise <sup>(3)</sup>	dB(A)	3	64~1,000	≤ 66	≤ 68	≤ 68	≤ 70	≤ 70	≤ 72	≤ 74
Efficiency $\eta$	%	3	64~1,000	≥ 92%						

(1) Ratio ( $i = N_{in} / N_{out}$ ).

(2) Backlash is measured at 2% of Nominal Output Torque  $T_{2N}$ .

(3) The dB values are measured by gearbox with ratio 1,000 (3-stage), no loading at 3,000 RPM or at the respective Nominal Input Speed by bigger model size.

By lower ratio and/or higher RPM, the noise level could be 3 to 5 dB higher.

(4) Applied to the output flange center at 100 rpm.

(5) Continuous operation is not recommended.

# Inertia - AHKB ( 3 stage ) Gearbox

Model No.	AHKB090	AHKB110	AHKB140	AHKB200	AHKB255	AHKB285	AHKB355
8	0.17	-	-	-	-	-	-
11	0.17	0.52	-	-	-	-	-
14	0.21	0.53	1.83	-	-	-	-
19	-	0.68	1.83	5.6	-	-	-
24	-	-	5.04	5.63	5.63	-	-
28	-	-	-	7.18	7.18	-	-
32	-	-	-	10.1	10.1	12.63	-
35	-	-	-	15.54	15.54	17.75	17.35
38	-	-	-	21.32	21.32	23.26	23.61
42	-	-	-	-	23.2	25.4	25.5
48	-	-	-	-	56.07	61.02	61.22

(A)  $\varnothing$  = Input shaft diameter.

# Dimension AHKB ( 3 stage ) Gearbox ( Ratio $i = 64 \sim 1,000$ )

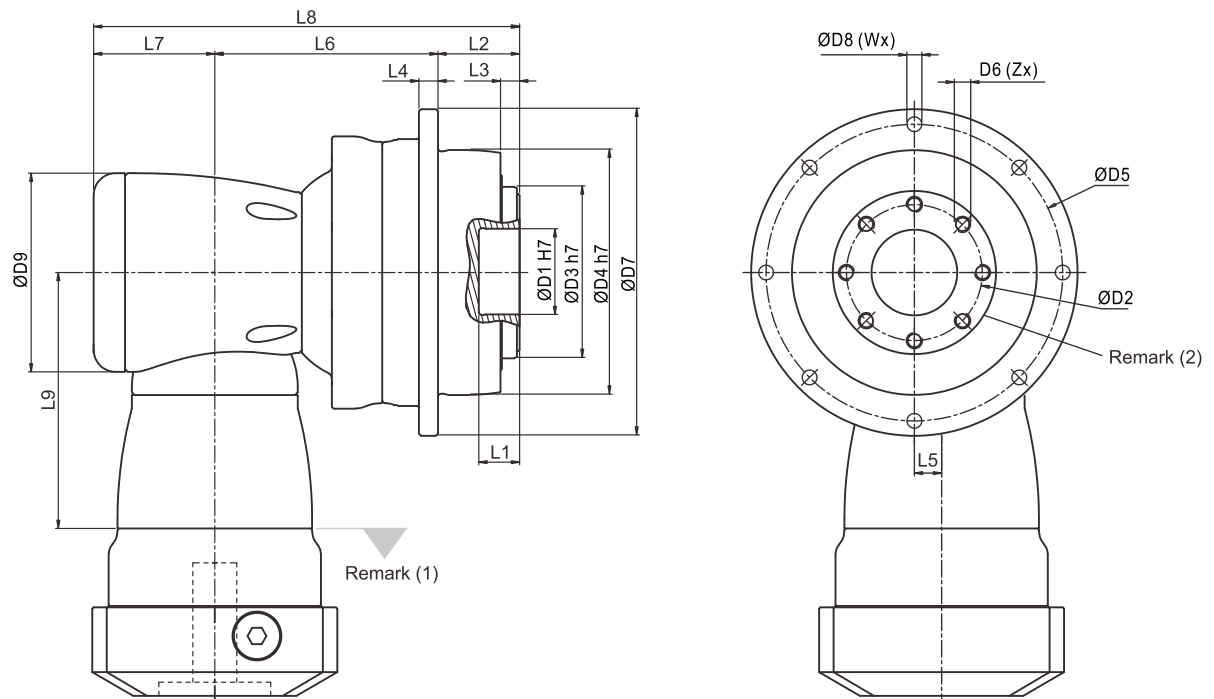

Dimension	AHKB090	AHKB110	AHKB140	AHKB200	AHKB255	AHKB285	AHKB355
D1 H7	31.5	40	50	80	100	100	120
D2	50	63	80	125	140	160	200
D3 h7	63	80	100	160	180	200	250
D4 h7	90	110	140	200	255	285	355
D5	109	135	168	233	280	310	385
D6 x Pitch x Deep	M6x1Px10	M6x1Px11	M8x1.25Px15	M10x1.5Px20	M16x2Px25	M20x2.5Px31	M24x3Px32
D7	120	147	180	249.5	302	332	415
D8	5.5	5.5	6.6	9	13.5	13.5	17.5
D9	94	116	163	210	210	255	300
L1	15	15	15	16	16	16	35
L2	30	29	38	50	66	75	80
L3	7	7	7.5	8.5	13.5	16.5	20
L4	7	8	10	12	18	20	45
L5	13	17	25	31	31	36	43
L6	90.5	114	147.5	175	191.5	249.5	290
L7	53	68.3	89	115	115	131	165
L8	173.5	211.3	274.5	340	372.5	455.5	535
L9	114.5	129	173.5	228	228	265.5	294.5
X in Degree	45	22.5	30	30	24	24	22.5
Y in Degree	45	22.5	30	30	24	24	22.5
Z	8	12	12	12	12	12	16
U in Degree	45	45	30	30	22.5	22.5	30
V in Degree	45	45	30	30	22.5	22.5	30
W	8	8	12	12	16	16	12

(1) Dimensions are related to motor interface. Please contact APEX for details.

(2) Refer to the AH series (Page 05) for flange interface.

# Performance - AHK ( 4 Stage ) Gearbox

Model No.	Stage	Ratio <sup>(1)</sup>	AHK285	AHK355	AHK450	
Nominal Output Torque $T_{2N}$	Nm	4	1,225	3,350	5,630	10,980
			1,400	3,350	5,630	10,980
			1,750	3,350	5,630	10,980
			2,000	3,350	5,630	10,980
			2,800	2,555	4,825	9,600
			3,500	3,350	5,630	10,980
			5,000	3,350	5,350	9,050
			7,000	2,625	4,960	10,115
		10,000	1,975	3,870	8,325	
Emergency Stop Torque $T_{2NOT}$	Nm	4	1,225~10,000			
Max. Acceleration Torque $T_{2B}$	Nm	4	1,225~10,000			
No Load Running Torque <sup>(3)</sup>	Nm	4	1,225~10,000			
Backlash <sup>(2)</sup>	arcmin	4	1,225~10,000			
Torsional Rigidity	Nm/arcmin	4	1,225~10,000			
Nominal Input Speed $n_{1N}$	rpm	4	1,225~10,000			
Max. Input Speed $n_{1B}$	rpm	4	1,225~10,000			
Max. Axial Load $F_{2a}$ <sup>(4)</sup>	N	4	1,225~10,000			
Max. Tilting Moment $M_{2K}$ <sup>(4)</sup>	Nm	4	1,225~10,000			
Operating Temp	°C	4	1,225~10,000			
Degree of Gearbox Protection		4	1,225~10,000			
Lubrication		4	1,225~10,000			
Mounting Position		4	1,225~10,000			
Running Noise <sup>(3)</sup>	dB(A)	4	1,225~10,000			
Efficiency $\eta$	%	4	1,225~10,000			

(1) Ratio ( $i = N_{in} / N_{out}$ ).

(2) Backlash is measured at 2% of Nominal Output Torque  $T_{2N}$ .

(3) The dB values are measured by gearbox with ratio 10,000 (4-stage), no loading at 3,000 RPM or at the respective Nominal Input Speed by bigger model size.

By lower ratio and/or higher RPM, the noise level could be 3 to 5 dB higher.

(4) Applied to the output flange center at 100 rpm.

(5) Continuous operation is not recommended.

## Inertia - AHK ( 4 Stage ) Gearbox

Model No.	AHK285	AHK355	AHK450
24	5.63	5.63	-
28	7.18	7.18	-
32	10.1	10.1	12.63
35	15.54	15.54	17.75
38	21.32	21.32	23.26

(A)  $\emptyset$  = Input shaft diameter.

# Dimension AHK ( 4 Stage ) Gearbox ( Ratio $i = 1,225 \sim 10,000$ )

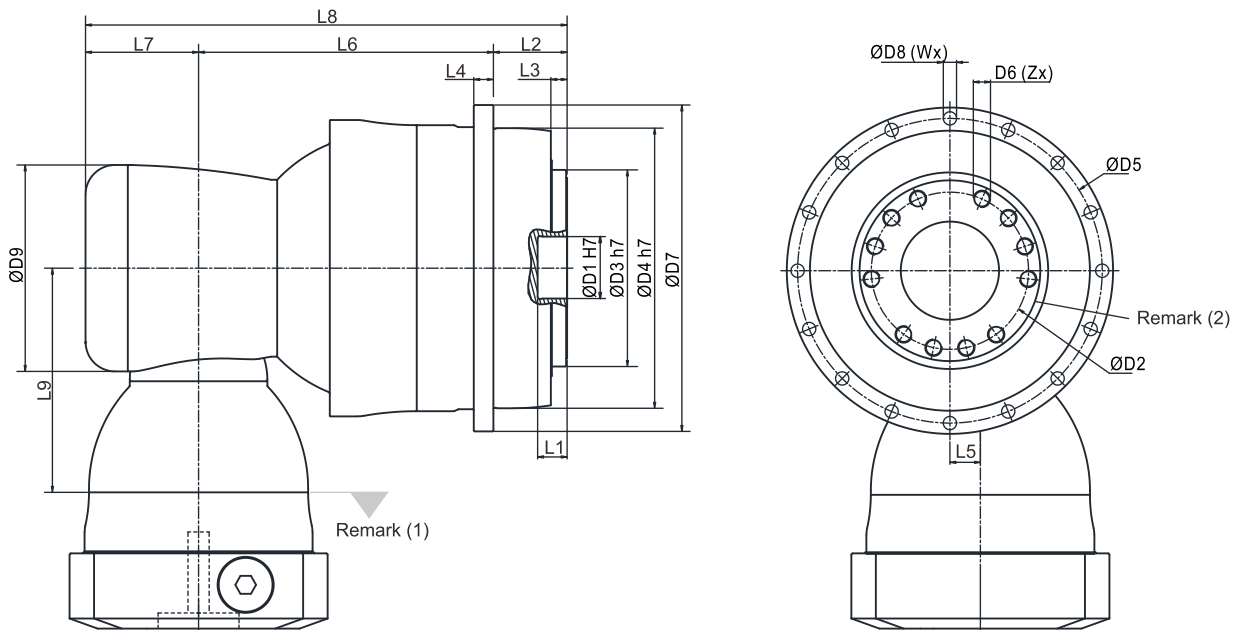

Dimension		AHK285	AHK355	AHK450
D1	H7	100	120	155
D2		160	200	250
D3	h7	200	250	315
D4	h7	285	355	450
D5		310	385	490
D6 x Pitch x Deep		M20x2.5Px31	M24x3Px32	M30x3.5Px40
D7		332	415	530
D8		13.5	17.5	22
D9		210	210	255
L1		16	35	24
L2		75	80	85
L3		16.5	20	20
L4		20	45	60
L5		31	31	36
L6		300	332	447.5
L7		115	115	131
L8		490	527	663.5
L9		228	228	265.5
X in Degree		24	22.5	30
Y in Degree		24	22.5	30
Z		12	16	12
U in Degree		22.5	30	30
V in Degree		22.5	30	30
W		16	12	12

(1) Dimensions are related to motor interface. Please contact APEX for details.

(2) Refer to the AH series (Page 05) for flange interface.



# Performance AHKC Gearbox

Model No.	Stage	Ratio <sup>(1)</sup>	AHKC064	AHKC090	AHKC110	AHKC140	AHKC200	AHKC255	AHKC285	AHKC355	AHKC450	
Nominal Output Torque $T_{2N}$	2	4	35	80	210	415	1,005	-	-	-	-	
		5	35	80	210	415	1,005	2,050	3,250	-	-	
		7	30	70	180	350	820	1,750	2,410	-	-	
		8	35	80	210	415	1,005	-	-	-	-	
	3	10	35	80	210	415	1,005	2,050	3,250	-	-	
		21	-	85	220	430	1,065	2,100	3,340	5,320	10,750	
		31	-	70	185	365	860	1,790	2,470	5,720	9,100	
		46	-	60	155	305	675	1,080	1,890	3,460	7,800	
		61	-	70	185	365	860	1,790	2,470	5,720	9,100	
		91	-	60	155	305	675	1,080	1,890	3,460	7,800	
Emergency Stop Torque $T_{2NOT}$	Nm	2,3	4~91	2 times $T_{2N}$								
Max. Acceleration Torque $T_{2B}$	Nm	2,3	4~91	1.5 times $T_{2N}$								
No Load Running Torque <sup>(3)</sup>	Nm	2	4~10	2	2.5	5.8	12	25	48	95	-	-
		3	21~91	1	1.5	2.5	4	9	18.5	35	75	148
Backlash <sup>(2)</sup>	arcmin	2	4~10	≤ 3	≤ 2	≤ 2	≤ 2	≤ 2	≤ 2	≤ 2	-	-
		3	21~91	-	≤ 2	≤ 2	≤ 2	≤ 2	≤ 2	≤ 2	≤ 2	≤ 2
Torsional Rigidity	Nm/arcmin	2,3	4~91	12	27	56	112	389	642	1,275	2,500	5,100
Nominal Input Speed $n_{1N}$	rpm	2	4~10	5,000	3,600	3,000	2,300	1,800	1,500	1,100	-	-
		3	21~91	-	4,600	4,000	3,000	2,300	1,800	1,500	1,500	1,100
Max. Input Speed $n_{1B}$	rpm	2	4~10	7,000	6,000	5,500	4,500	3,500	3,000	2,200	-	-
		3	21~91	-	7,000	6,500	5,500	4,500	3,500	3,000	3,000	2,200
Max. Axial Load $F_{2a}$ <sup>(4)</sup>	N	2,3	4~91	1,690	2,220	4,070	8,530	17,000	26,900	39,200	101,500	143,700
Max. Tilting Moment $M_{2K}$ <sup>(4)</sup>	Nm	2,3	4~91	120	280	480	1,310	3,530	5,920	9,230	29,100	63,300
Operating Temp	°C	2,3	4~91	-10° C ~ 90° C								
Degree of Gearbox Protection		2,3	4~91	IP65								
Lubrication		2,3	4~91	Synthetic lubrication grease								
Mounting Position		2,3	4~91	All directions								
Running Noise <sup>(3)</sup>	dB(A)	2	4~10	≤ 68	≤ 68	≤ 68	≤ 70	≤ 70	≤ 72	≤ 74	-	-
		3	21~91	-	≤ 68	≤ 68	≤ 70	≤ 70	≤ 72	≤ 74	≤ 74	≤ 76
Efficiency $\eta$	%	2	4~10	≥ 95%								
		3	21~91	≥ 93%								

(1) Ratio ( $i = N_{in} / N_{out}$ ).

(2) Backlash is measured at 2% of Nominal Output Torque  $T_{2N}$ .

(3) The dB values are measured by gearbox with ratio 10 (2-stage) or ratio 91 (3-stage), no loading at 3,000 RPM or at the respective Nominal Input Speed by bigger model size.

By lower ratio and/or higher RPM, the noise level could be 3 to 5 dB higher.

(4) Applied to the output flange center at 100 rpm.

(5) Continuous operation is not recommended.

## Inertia AHKC Gearbox (Ratio $i = 4 \sim 10 / 21 \sim 91$ )

Model No.	AHKC064	AHKC090	AHKC110	AHKC140	AHKC200	AHKC255	AHKC285	AHKC355	AHKC450						
$\emptyset^{(A)}$ (C3)	2-st.	2-st.	3-st.	2-st.	3-st.	2-st.	3-st.	2-st.	3-st.	2-st.	3-st.	2-st.	3-st.	3-st.	3-st.
8	0.1	-	0.1	-	-	-	-	-	-	-	-	-	-	-	-
11	0.17	0.52	0.17	-	-	-	-	-	-	-	-	-	-	-	-
14	0.21	0.52	0.21	-	0.52	-	-	-	-	-	-	-	-	-	-
19	0.62	1.69	0.62	1.71	1.69	-	1.71	-	-	-	-	-	-	-	-
24	-	4.89	-	5.05	4.89	6.92	5.05	-	6.92	-	-	-	-	-	-
28	-	-	-	6.55	-	6.98	6.55	-	6.98	-	-	-	-	-	-
32	-	-	-	9.47	-	10.18	9.47	10.18	10.18	-	10.18	-	-	-	-
35	-	-	-	14.91	-	15.21	14.91	15.21	15.21	15.68	15.21	23.46	15.68	-	-
38	-	-	-	20.69	-	20.7	20.69	20.7	20.7	21.69	20.7	23.46	21.69	21.69	-
42	-	-	-	-	-	22.83	-	22.83	22.83	23.59	22.83	25.28	23.59	23.59	25.28
48	-	-	-	-	-	58.45	-	58.45	58.45	59.3	58.45	61.61	59.3	59.3	61.61
55	-	-	-	-	-	-	-	-	-	86.95	-	89.67	-	86.95	89.67
60	-	-	-	-	-	-	-	-	-	-	-	112.49	-	-	112.49

(A)  $\emptyset$  = Input shaft diameter.

# Dimension AHKC Gearbox ( Ratio $i=4\sim 10 / 21\sim 91$ )

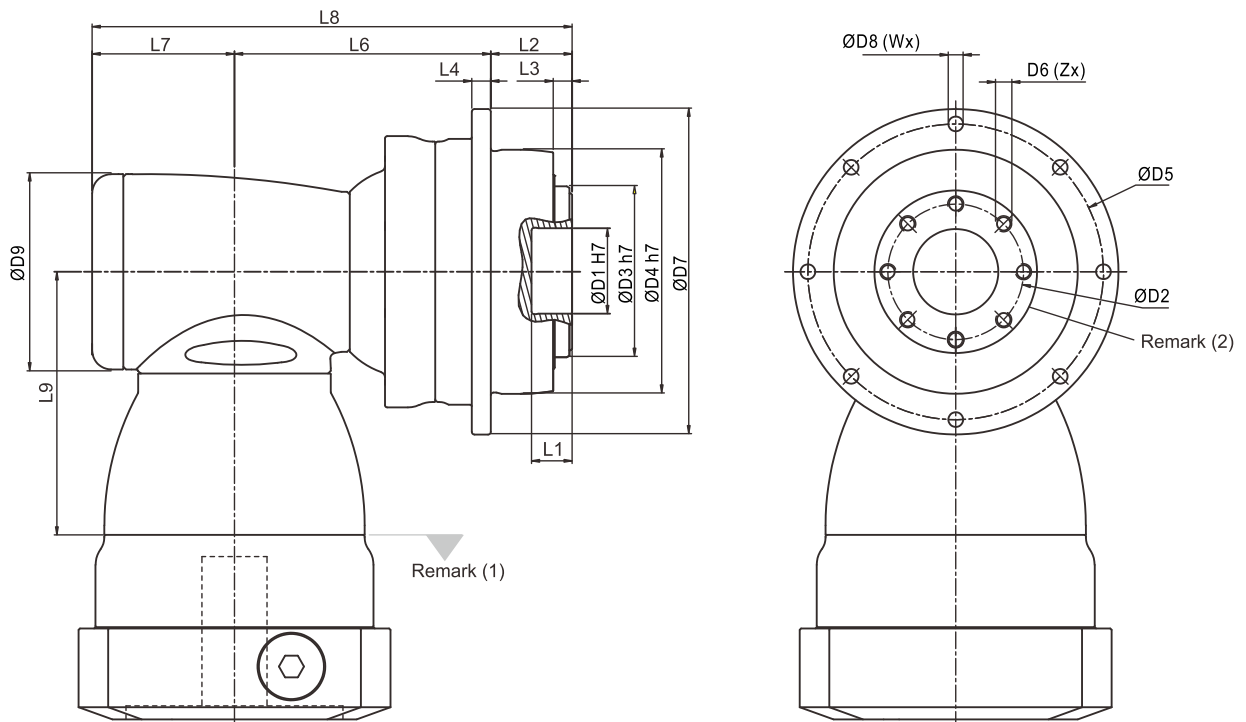

Dimension	AHKC064		AHKC090		AHKC110		AHKC140		AHKC200		AHKC255		AHKC285		AHKC355	AHKC450
	2-st.	3-st.	2-st.	3-st.	2-st.	3-st.	2-st.	3-st.	2-st.	3-st.	2-st.	3-st.	2-st.	3-st.	3-st.	3-st.
D1 H7	20		31.5		40		50		80		100		100		120	155
D2	31.5		50		63		80		125		140		160		200	250
D3 h7	40		63		80		100		160		180		200		250	315
D4 h7	64		90		110		140		200		255		285		355	450
D5	79		109		135		168		233		280		310		385	490
D6 x Pitch x Deep	M5x0.8Px8		M6x1Px10		M6x1Px11		M8x1.25Px15		M10x1.5Px20		M16x2Px25		M20x2.5Px31		M24x3Px32	M30x3.5Px40
D7	88		120		147		180		249.5		302		332		415	530
D8	4.5		5.5		5.5		6.6		9		13.5		13.5		17.5	22
D9	64	92	64	116	92	156	116	156	156	195	156	240	195	195	195	240
L1	8		15		15		15		16		16		16		35	24
L2	19.5		30		29		38		50		66		75		80	85
L3	4		7		7		7.5		8.5		13.5		16.5		20	20
L4	5		7		8		10		12		18		20		45	60
L6	92	100.5	121.5	124.5	142	175.5	174.5	185	244.5	199	264.5	265.5	307.5	339.5	463.5	
L7	46.5	61.5	46.5	76	61.5	97.5	76	97.5	97.5	105.5	97.5	141	105.5	105.5	141	
L8	158	192	198	229.5	232.5	311	288.5	332.5	392	370.5	428	481.5	488	525	689.5	
L9	81.5	113.5	81.5	147.5	113.5	196.5	147.5	196.5	196.5	229	196.5	260	229	229	260	
X in Degree	45		45		22.5		30		30		24		24		22.5	30
Y in Degree	45		45		22.5		30		30		24		24		22.5	30
Z	8		8		12		12		12		12		12		16	12
U in Degree	45		45		45		30		30		22.5		22.5		30	30
V in Degree	45		45		45		30		30		22.5		22.5		30	30
W	8		8		8		12		12		16		16		12	12

(1) Dimensions are related to motor interface. Please contact APEX for details.

(2) Refer to the AH series (Page 05) for flange interface.

# Selection of the optimum gearbox

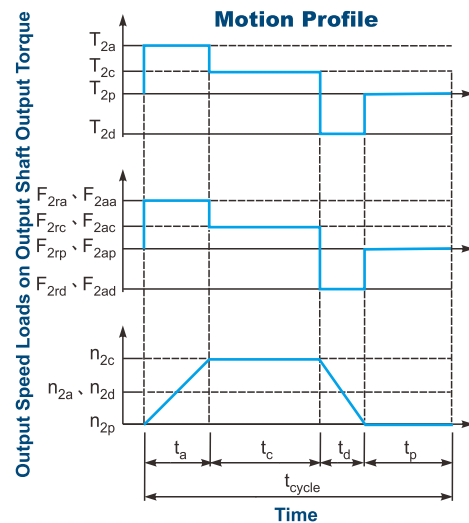
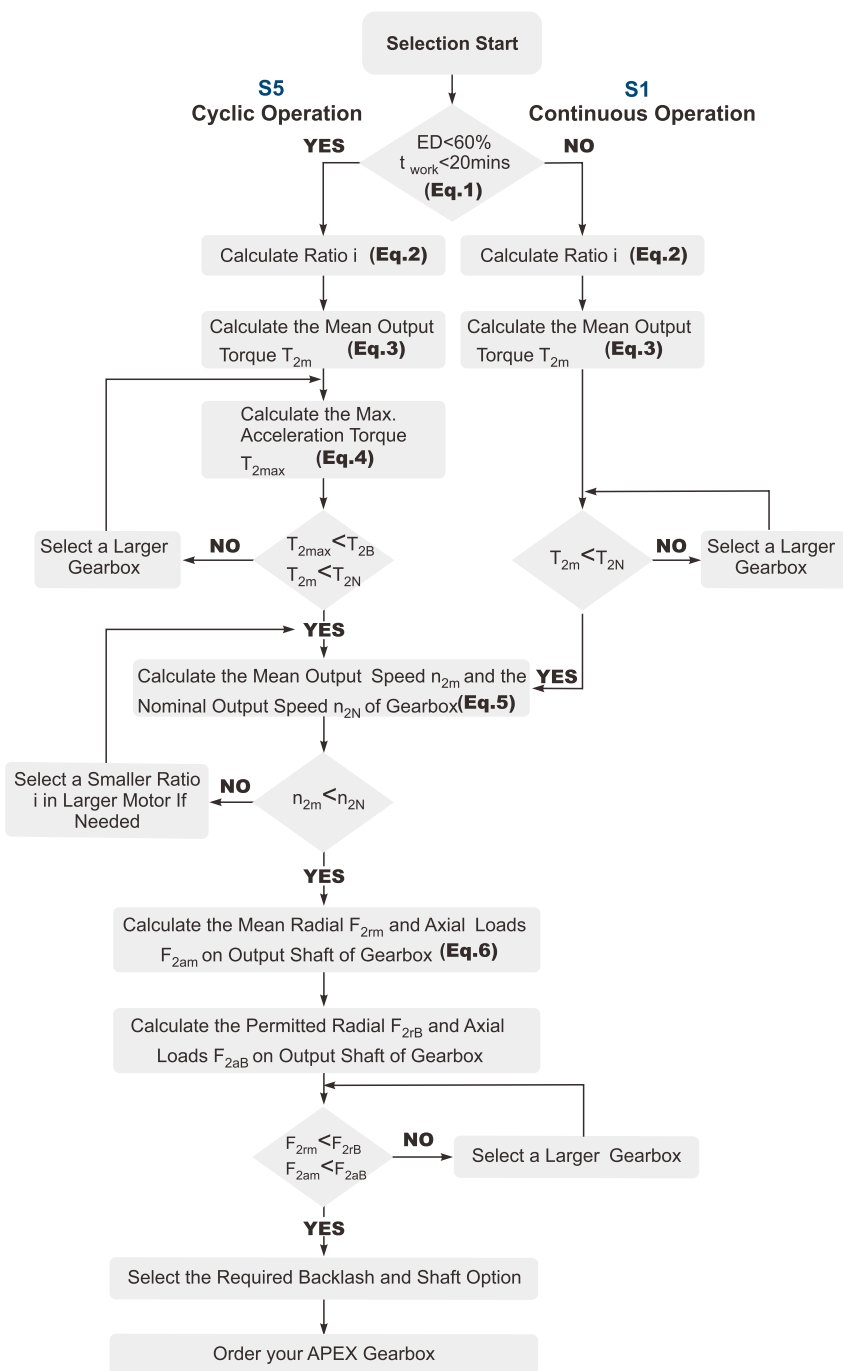

$$1. ED = \frac{t_a + t_c + t_d}{t_{cycle}} \times 100\%, t_{work} = t_a + t_c + t_d$$

Index : a. Acceleration, c. Constant,  
d. Deceleration, p. Pause **(Eq.1)**

$$2. i \cong \frac{n_m}{n_{work}}$$

$n_m$  Output Speed of the Motor  
 $n_{work}$  Working Speed **(Eq.2)**

$$3. T_{2m} = 3 \sqrt{\frac{n_{2a} \times t_a \times T_{2aa}^3 + n_{2c} \times t_c \times T_{2ac}^3 + n_{2d} \times t_d \times T_{2ad}^3}{n_{2a} \times t_a + n_{2c} \times t_c + n_{2d} \times t_d}}$$

**(Eq.3)**

$$4. T_{2max} = T_{mB} \times i \times K_s \times \eta$$

where  $K_s$  is

$K_s$	No. of Cycles / hr
1.0	0 ~ 1,000
1.1	1,000 ~ 1,500
1.3	1,500 ~ 2,000
1.6	2,000 ~ 3,000
1.8	3,000 ~ 5,000

$T_{mB}$  Max. Output Torque of the Motor

$\eta$  Efficiency of the Gearbox **(Eq.4)**

$$5. n_{2a} = n_{2d} = \frac{1}{2} \times n_{2c}$$

$$n_{2m} = \frac{n_{2a} \times t_a + n_{2c} \times t_c + n_{2d} \times t_d}{t_a + t_c + t_d}$$

$$n_{2N} = \frac{n_{1N}}{i}$$

**(Eq.5)**

$$6. F_{2rm} = 3 \sqrt{\frac{n_{2a} \times t_a \times F_{2ra}^3 + n_{2c} \times t_c \times F_{2rc}^3 + n_{2d} \times t_d \times F_{2rd}^3}{n_{2a} \times t_a + n_{2c} \times t_c + n_{2d} \times t_d}}$$

$$F_{2am} = 3 \sqrt{\frac{n_{2a} \times t_a \times F_{2aa}^3 + n_{2c} \times t_c \times F_{2ac}^3 + n_{2d} \times t_d \times F_{2ad}^3}{n_{2a} \times t_a + n_{2c} \times t_c + n_{2d} \times t_d}}$$

**(Eq.6)**

### Recommended (for S5 Cycle Operation)

The general design is given for

$$\frac{J_L}{i^2} \leq 4 \times J_m$$

The optimal design is given for

$$\frac{J_L}{i^2} \cong J_m$$

$J_L$  Load Inertia

$J_m$  Motor Inertia

# Glossary

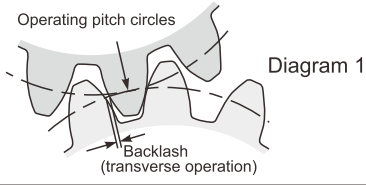
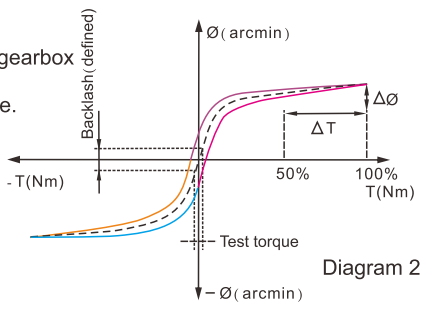
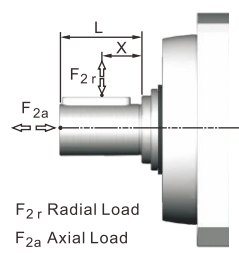
Emergency Stop Torque $T_{2NOT}$	Nm	The Emergency Stop Torque is the maximum permitted torque at the output of gearbox. This may happen only occasionally and may not exceed 1,000 times during the whole service life.
Max. Acceleration Torque $T_{2B}$	Nm	Under the Cyclic Operation (S5), the Max. Acceleration Torque is the maximum torque which can be transmitted only briefly to the output of gearbox up to 1,000 cycles/hr.
No Load Running Torque	Nm	The No Load Running Torque is the min. torque to overcome the internal friction of a gearbox without loading*.
Nominal Input Speed $n_{1N}$	rpm	The Nominal Input Speed is the permitted input speed of gearbox by the Continuous Operation (S1) while the housing temperature does not exceed 90°C. This value is measured at environment temperature 25°C.
Max. Input Speed $n_{1B}$	rpm	The Max. Input Speed is the max. permitted input speed of gearbox by the Cyclic operation (S5). This value is measured at environment temperature 25°C and serves as the absolute limit of the gearbox.
Backlash	arcmin	<p>The Backlash is the maximum angular measurement between two teeth of gears when the transverse operation occurs (refer to Diagram 1). The arcmin is the measurement unit for the backlash. One arcmin equals 1/60 degree, symbolized as 1'.</p> 
Torsional Rigidity	Nm/arcmin	<p>Torsional Rigidity is the quotient (<math>\Delta T / \Delta \theta</math>) between the applied torque and resulting torsion angle. This value indicates how much torque is needed on the gearbox to rotate the output shaft for 1 arcmin. The Torsional Rigidity can be determined by Hysteresis Curve.</p> <p>Hysteresis Curve When the input shaft is locked, increase torque at the output slowly up to <math>T_{2B}</math> in both directions and then release the torque gradually. According to the measured torque and torsion angle, a closed curve will be acquired as in the Diagram 2.</p> 
Radial Load And Axial Load	N	<p>The permitted radial and axial loads on output shaft of the gearbox depend on the design of the gearbox supporting bearings.</p> <p>For more information, please refer to APEX website.</p> 
Efficiency $\eta$	%	The transmission efficiency of the gears inside a gearbox (without friction).
Operating Temperature	°C	The Operating Temperature indicates the temperature of gearbox housing.
Degree of Protection		IP code stands for International Protection standard. The IP65 as example: the first IP number stands for protection degree against dust; the second IP number stands for protection against liquid.
Lubrication		APEX uses synthetic lubrication grease. Alternate greases are available, please contact APEX.
Running Noise	dB(A)	The Running Noise is measured depends on gearbox size, the ratio and the speed*. Higher speed usually induces higher noise level, while higher ratio induces lower noise level.
Moment of Inertia $J_1$	kg.cm <sup>2</sup>	The Moment of Inertia $J_1$ is a measurement of the effort applied to an object to maintain its momentary condition at rest or rotating.
Breakaway Torque	Nm	The Breakaway Torque is the minimum torque to start the rotation from the input side of gearbox. A smaller size or a higher ratio gearbox requests less Breakaway Torque.
Back Driving Torque	Nm	The Back Driving Torque is the minimum torque to start the rotation from the output side of gearbox. A larger size or a higher ratio gearbox requires greater Back Driving Torque.

\* This value is measured at environment temperature 25°C and the input speed 3,000 rpm. If the Nominal Input Speed  $n_{1N}$  of gearbox is lower than 3,000 rpm, this value is measured by that specific Nominal Input Speed.

# Note



**APEX TAIWAN NORTH  
ANDTEK AUTOMATION CO.,LTD**  
TEL +886-02-82262655  
13F-5, No.2, Jian 8th Rd., Jhonghe Dist., New  
Taipei City 235, TAIWAN  
sales@andtek.com.tw  
www.apexdyna.com



**APEX TAIWAN CENTRAL  
ANDTEK AUTOMATION CO.,LTD**  
TEL +886-04-23594286  
9F-6, No.925, Sec.4, Taiwan Blvd., Xitun Dist.  
Taichung City 407 TAIWAN  
sales@andtek.com.tw  
www.apexdyna.com



**APEX TAIWAN SOUTH  
MEN JENN ELECTRIC CO., LTD.**  
TEL +886-06-2337332 ~ 6  
No.774, Zhonghua Rd., Yongkang Dist., Tainan  
City 710, TAIWAN  
menjenn@ms24.hinet.net  
www.apexdyna.com



**APEX DYNAMICS INC. SHANGHAI**  
TEL +86-21-69220577  
No.128 ZHUYING Road QINGPU Industry Area,  
Shanghai, CHINA  
sales@apexdyna.cn  
www.apexdyna.com



**APEX DYNAMICS SHENZHEN, LTD.**  
TEL +86-755-84516325  
No. 1102A of D area , CFG mansion ,Bao Yuan  
Road , Bao' an District , Shenzhen ,CHINA.  
sales@szapexdyna.com  
www.szapexdyna.com



**APEX DYNAMICS BEIJING, LTD.**  
TEL +86-10-69570691  
NO.1,YaoPingRoad,SongZhuang Town, Tongzhou  
istrict, Beijing, CHINA.  
bjapexdyna@163.com  
www.bjapex.cn



**CHONGQING APEX DYNAMICS CO., LTD.**  
TEL +86-23-67686860  
406, Building 5, No.68, Jinyu Avenue, Beibu New  
Area, Chongqing, CHINA  
sales@cqapexdyna.com  
www.apexdyna.com



**APEX (XIAMEN) DYNAMICS TECHNOLOGY CO., LTD.**  
TEL +86-0592-720-5279  
Unit B-3,1F.,No.129,Jingquan Road, Jimei District,  
Xiamen, Fujian, CHINA  
sales@xmmapexdyna.com  
www.xmapexdyna.com



**APEX DYNAMICS USA, INC.**  
TEL +1-631-2449040  
885 Marconi Avenue Ronkonkoma, NY 11779  
U.S.A.  
sales@apexdynamicsusa.com  
www.apexdynamicsusa.com



**APEX DYNAMICKOREA INC**  
TEL +82-31-8179992  
7-5, Aenigol-gil, Ilsandong-gu, Goyang-si, Gyeonggi-do,  
Republic of Korea 10301  
sales@apexdynakorea.co.kr  
www.apexdynakorea.co.kr



**APEX DYNAMICS JAPAN**  
TEL +88-092-4511202  
1-3-46, Hanmichibasi, Hakata-ku, Fukuoka,  
812-0897, JAPAN  
sales@apexdyna.jp  
www.apexdyna.jp



**APEX DYNAMICS SINGAPORE PTE LTD**  
TEL +65-62-626228  
3 South Buona Vista Road, #05-15 & #06-15.  
SINGAPORE 118136  
sales@apexdyna.com.sg  
www.apexdyna.com.sg



**APEX DYNAMICS (THAILAND) CO., LTD.**  
TEL +66-2-326623  
87 Soi Ladkrabang 30, Ladkrabang, Ladkrabang,  
Bangkok 10520, Thailand  
Apexthal2010@gmail.com  
www.apexdyna.co.th



**APEX DYNAMICS BV**  
TEL +31-492-509995  
Churchillaan 101 5705 BK Helmond, NETHERLANDS  
sales@apexdyna.nl  
www.apexdyna.nl  
www.apexdyna.be



**APEX DYNAMICS  
POLSKA SP. Z O.O.**  
TEL +48-12-6304728  
Ul. Krakowska 50, 32-083 Balice, Poland  
sales@apexdyna.pl  
www.apexdyna.pl



**APEX DYNAMICS SPAIN, S.L.**  
TEL +34-93-6562990  
Poligono Industrial Moli dels Freres, Calle Cnº  
12,08620 - Sant Vicenç dels Horts, Barcelona, SPAIN  
apexdyna@apexdyna.es  
www.apexdyna.es



**LIMAN TRADING LIMITED FZC LLC**  
P.O. Box 97 , Postal Code 322, Corporate Parks,  
Sohar Free Zoon, Oman



**APEKS DINAMIK REDUKTOR DISLI SAN TIC AS**  
TEL +90-232-4589960  
10053 SOKAK NO: 9 A.O.S.B. CIGLI – IZMIR– TURKEY  
sales@apexdyna.com.tr  
www.apexdyna.com.tr



**APEX DYNAMICS AUSTRALIA PTY LTD.**  
TEL +613-95-852739  
36 Taunton Drive, Cheltenham, Victoria 3192  
AUSTRALIA.  
sales@apexdyna.com.au  
www.apexdyna.com.au



**APEX DYNAMICS (I) JV**  
TEL +91-9607927142  
Shop No. 02, S. No. 100/5, Pune-Satara Highway,  
Ambegaon Khurd, Pune-411046 Maharashtra, India  
sales@apexdyna.co.in  
www.apexdyna.co.in



**APEX DYNAMICS FRANCE SAS**  
TEL +33-160-135097  
11 - Burospace - 91570 - Bièvres, France  
info@apexdyna.fr  
www.apexdyna.fr



**APEX DYNAMICS SWEDEN AB**  
TEL +46-75-242444  
Fredrikbergsgatan 2 SE-573 92 Tranås, SWEDEN  
sales@apexdyna.se  
www.apexdyna.se



**PT.APEX DYNAMICS INDONESIA**  
TEL +62 21 2928 3681  
Rukan Aralia Blok HY43 no.11, Harapan Indah II,  
Bekasi - Jawa Barat, INDONESIA 17214  
sales@apexdyna.co.id  
www.apexdyna.co.id



**APEX DYNAMICS GERMANY GMBH**  
TEL +49-7171 798069-0  
Marie-Curie-Straße 25 D-73529 Schwäbisch Gmünd  
wermerlanger@apexdynamics.de  
www.apexdynamics.de



**APEX DYNAMICS CZECH S.R.O.**  
TEL +420-577-663877  
tř. Tomáše Bati 1851 765 02 Otrokovice ČESKÁ  
REPUBLIKA  
info@apexdynaczech.cz  
www.apexdynaczech.cz



**APEX DYNAMICS РОССИЯ**  
TEL +7-495-2255452  
+7-495-6462422  
г.Москва, ул. Южнопортовая, дом 7, строение  
"С", 3-й этаж  
info@apexdynarussia.ru  
www.apexdynarussia.ru



**APEX DYNAMICS MIDLANDS LTD**  
TEL +44-0121-737-1170  
Heath House, Cheadle Rd, Uxeter,  
ST14 7BY, UK  
mikeg@apexdynauk.com  
www.apexdynauk.com



**APEX DYNAMICS SWITZERLAND AG**  
TEL +41-55-4517020  
Obergasse 40, CH-8854 Galgenen, Switzerland  
info@apexdyna.ch  
www.apexdyna.ch



**APEX DYNAMICS MOTION (M) SDN BHDTEL**  
TEL +60 7237 1055  
Block A1-2, #35-03, Mercu 1 Jalan Tanjung Puteri 1,  
R & F Tanjung Puteri, Johor Bahru 80300, Johor.  
sales@apexdyna.com.sg  
www.apexdyna.com.sg



**APEX DYNAMICS BRAZIL**  
TEL +55-47-30298700  
Rua Senador Petrônio Portela, 47 - Bloco 5, Zona  
Industrial Norte - CEP 89218-575 - Joinville (SC)  
lucan@neoyama.com.br  
adriano.duarte@neoyama.com.br  
www.neoyama.com.br



**APEX DYNAMICS ITALY SRL**  
TEL +39 02 36634521  
VIA E. DE AMICIS, 2-20091 BRESSO (MI)  
info@apexdynamics.it  
www.apexdynamics.it



**APEX DYNAMICS AUSTRIA GmbH**  
TEL +43 720788416  
Dr. Hans-Lechner-Strasse 6,  
5071 Wals-Siezenheim  
info@apexdynamics.at  
www.apexdynamics.at



**UAB "APEKSO DINAMIKA"**  
TEL +370 52078165  
Medaus g. 28A,  
Medininku k., Vilniaus r. Sav.  
LT-13192  
info@apexdyna.lt



**APEX DYNAMICS DENMARK**  
TEL +45 73121260  
Grundtvigs Allé 165, 6400  
Sønderborg, Denmark  
sales@apexdyna.dk  
www.apexdyna.dk



**APEX DYNAMICS ISRAEL**  
TEL +972-3-6470471  
17 Hamefalsim St., Kiryat Arye,  
Petach-Tikva 4951447  
Sales@apexdynamics.co.il  
www.apexdynamics.co.il



**APEX DYNAMICS SLOVAKIA S.R.O.**  
TEL +421919400476  
Trenčianska cesta 887/52, 957 01  
Bánovce nad Bebravou, Slovak republic  
office@apexdyna.sk  
www.apexdyna.sk



## APEX DYNAMICS, INC.

No10. Keyuan 3rd RD.Situn District, Taichung City 40763, Taiwan (R.O.C)  
Tel:886-4-24650219 | Fax:886-4-24650118  
sales@apexdyna.com | http://www.apexdyna.com

APEX-2022-01-AH/AHK Series -1.0-TWN

Printed in Taiwan

