



AX500 Intelligent Controller

Intelligent Controller User Guide

AX500 Intelligent Controller

AX500 intelligent controller is a medium-sized PLC developed based on CODESYS. It fully supports IEC61131-3 programming system and multiple site real-time bus. It supports cam, CNC, and other synchronous movement control providing various interfaces to meet the needs of projects.

This manual describes the specifications, characteristics and using methods of the AX500 controller. For the user program, hardware information and other information of this product, please refer to the other manual.

Safety Instructions

Safety Precautions

1. Before installing, operating, and maintaining the product, please read and observe these safety precautions.
2. To ensure personal and equipment safety, please follow all marks on the product and safety

precautions of the manual when installing, operating, and maintaining the product.

3. The "CAUTION", "WARNING" and "DANGER" items in the manual do not represent all the safety matters to be observed but are supplementary to all safety precautions.

4. This product should be used in an environment stated in the design specifications. Otherwise, it may cause malfunctions. Functional abnormalities or component damages caused by failure to comply with relevant regulations are not at the range of product quality guarantee.

5. Our company will not bear any legal responsibility for personal safety accidents, property losses, and others caused by irregularities.

Safety Level Definition

 **WARNING:** Indicates the improper operation which, if not avoided, may cause death or serious injury;

 **CAUTION:** Indicates the improper operation which, if not avoided, may cause moderate or minor injury, as well as equipment damage.

Please keep this guide well so that it can be read when necessary and forward this guide to the end user.

Control System Designing

 **WARNING**

- ◆ Provide a safety circuit outside the PLC so that the control system can still work safely once external power failure or PLC fault occurs.
- ◆ Add a fuse or circuit breaker because the module may smoke or catch fire due to long-time overcurrent caused by operation above rated current or load short-circuit.

 **CAUTION**

- ◆ An emergency stop circuit, a protection circuit, a forward/reverse operation interlocked circuit, and a upper position limit and lower position limit interlocked circuit must be set in the external circuits of the PLC to prevent damage to the machine;
- ◆ To ensure safe operation, for the output signals that may cause critical accidents, please design external protection circuit and safety mechanism;
- ◆ Once PLC CPU detects abnormality in the system, all outputs may be closed; however, when a fault occurs in the controller circuit, the output may not be under control. Therefore, it is necessary to design an appropriate external control circuit to ensure normal operation;
- ◆ If the PLC's output units such as relays or transistors are damaged, the output may fail to switch between ON and OFF states according to the commands;
- ◆ The PLC is designed to be used in indoor electrical environment (overvoltage category II). The power supply must have a system-level lightning protection device, assuring that overvoltage due to

lightning shock can't be applied to the PLC's power supply input terminals, signal input terminals and output terminals and so forth, so as to avoid damage to the equipment.

Wiring

WARNING

- ◆ Wiring must be carried out by personnel who have the necessary electrical training and experience.
- ◆ Disconnect all external power supplies of the system before wiring. Failure to comply may result in electric shock, module fault or malfunction.
- ◆ Install the terminal cover attached to the product before power-on or operation after wiring is completed. Failure to comply may result in electric shock.
- ◆ Perform good insulation on terminals so that insulation distance between cables will not reduce after cables are connected to terminals. Failure to comply may result in electric shock or damage to the equipment."

CAUTION

- ◆ Prevent dropping metal filings and wire ends drop into ventilation holes of the PLC at wiring. Failure to comply may result in fire, fault and malfunction.
- ◆ The external wiring specification and installation method must comply with local regulations. For details, see the wiring section in this guide.
- ◆ To ensure safety of equipment and operator, use cables with sufficient diameter and connect the cables to ground reliably.
- ◆ Wire the module correctly after making clear of the connector type. Failure to comply may result in module and external equipment fault. Tighten bolts on the terminal block in the specified torque range. If the terminal is not tight, short-circuit, fire or malfunction may be caused. If the terminal is too tight, fall-off, short-circuit, fire or malfunction may be caused.
- ◆ If the connector is used to connect with external equipment, perform correct crimping or welding with the tool specified by manufacturer. If connection is in poor contact, short-circuit, fire or malfunction may be caused.
- ◆ A label on the top of the module is to prevent foreign matters entering the module. Do not remove the label during wiring. Remember to remove it before system operation, facilitating ventilation.
- ◆ Do not bundle control wires, communication wires and power cables together. They must be run with distance of more than 100 mm. Otherwise, noise may result in malfunction.
- ◆ Select shielded cable for high-frequency signal input/output in applications with serious interference so as to enhance system anti-interference ability.

Maintenance & Inspection

WARNING

- ◆ Maintenance & inspection must be carried out by personnel who have the necessary electrical training and experience.
- ◆ Do not touch the terminals while the power is on. Failure to comply may result in electric shock or malfunction.
- ◆ Disconnect all external power supplies of the system before cleaning the module or retightening screws on the terminal block or screws of the connector. Failure to comply may result in electric shock.
- ◆ Disconnect all external power supplies of the system before removing the module or connecting/removing the communication wirings. Failure to comply may result in electric shock or malfunction.

CAUTION

- ◆ Get acquainted with the guide and ensure safety before online modification, forcible output, and RUN/STOP operation;
- ◆ Disconnect the power supply before installing/removing the extension card.

Disposal

CAUTION

- ◆ Treat scrapped module as industrial waste. Dispose the battery according to local laws and regulations.

Product Information

Product Naming Rules

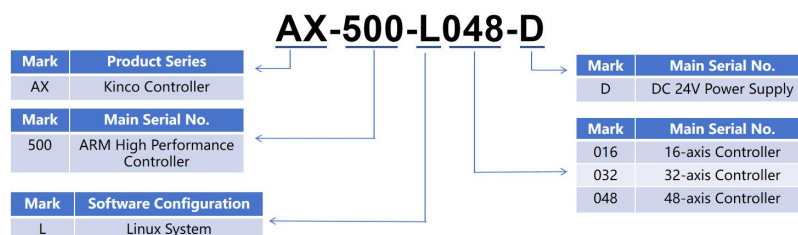

Product Nameplate

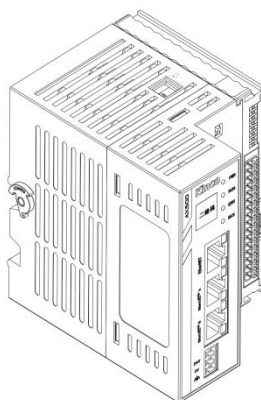

General Specifications

Item	AX500
Power Supply	DC 24V (-25% ~ +20%)
CPU Specifications	Quad-core 1.5GHz
Memory	2G
Hard Drive Capacity	8G
Program Capacity	32MB
User Data Capacity	128MB
Non-volatile Storage Capacity	3MB
USB	1* USB 2.0
Network	1* Gigabit Ethernet Port; 2* Fast Ethernet Ports
Serial Port	2* RS485; 1* RS232
Dimensions (mm)	78 × 98 × 100
Adapter Power Supply	Supports 24V DC Adapter Power Supply
Operating Temperature	-20°C~ +60°C
Axis Capability	Support 1ms for 8-axis synchronous control, with a maximum support of 48-axis synchronous control

Components Information

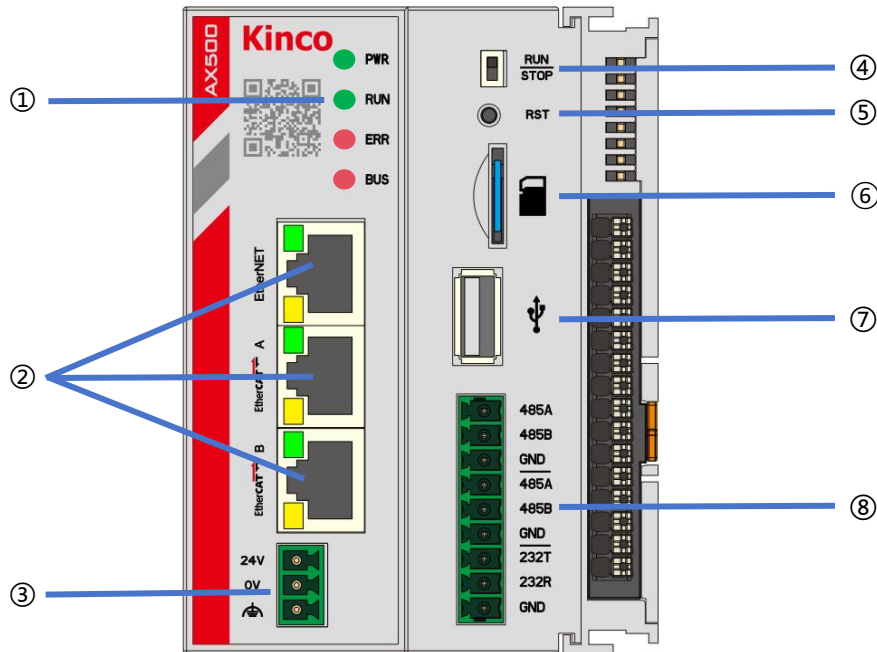

No.	Name	Description		
①	Status Indicator	Status Indicator		
	The indicators on the display panel from top to bottom are PWR/RUN/ERR/BUS, specific definitions are as follows:			
	Name	Sign	Status	Description
	PWR	Power Indicator	Green	ON: Power On
	RUN	Running Indicator	Green	ON: User Program Startup
	ERR	Error Indicator	Red	ON: User Program Fault
	BUS	Communication Indicator	Red	ON: Communication Fault
②	Network	3 Ethernet ports: EtherNet, EtherCAT A, and EtherCAT B. Provided in the form of RJ45. Default IP are as follows: EtherNET: 192.168.1.100; EtherCAT B: 192.168.2.100.		

Port	Function	Description
EtherNet	Ethernet	1. User program download and debugging 2. Modbus TCP 3. Socket (TCP, UDP)
EtherCAT A	EtherCAT	1. EtherCAT Master 2. Support Auto-Scan 3. Support Independent Configuration of Axis/IO
EtherCAT B	EtherCAT/ Ethernet	1. EtherCAT Master 2. Support Auto-Scan 3. Support Independent Configuration of Axis/IO 4. User program download and debugging 5. Modbus TCP 6. Socket (TCP, UDP)

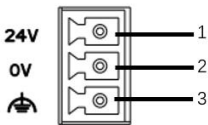
③	Power Supply	Power by DC 24V, definition of the power terminals are described as follows:		
	Power Terminal	No.	Type	Function
		1	+24V	Positive Terminal
		2	0V	Negative Terminal
3		GND	Ground Terminal	
The power input terminal is a 3-pin European terminal with a 5.08mm pitch, designed for screw fixation, making plugging and unplugging very convenient. The wiring employs a spring-clip crimping method, which is extremely user-friendly for on-site installation, wiring, replacement, and maintenance.				

④	RUN/STOP	To activate/stop user program
⑤	Reset Button	Long press until the RUN light blinks to reset to default IP; Continue holding to clear the user program and restart.
⑥	TF Card Slot	System Firmware Upgrade
⑦	USB	File Transfer: firmware upgrade

The definition of the communication terminal pins is as follows:

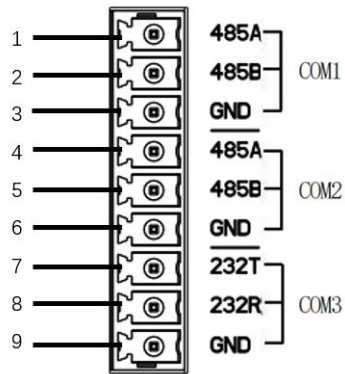

⑧

Pin	Name	Function
1	485A	RS485+(COM1)
2	485B	RS485-(COM1)
3	GND	485 Communication Ground
4	485A	RS485+(COM2)
5	485B	RS485-(COM2)
6	GND	RS485 Communication Ground
7	232T	R232 Reception (COM3)
8	232R	R232 Transmission (COM3)
9	GND	RS232 Communication Ground

Power Terminal Arrangement

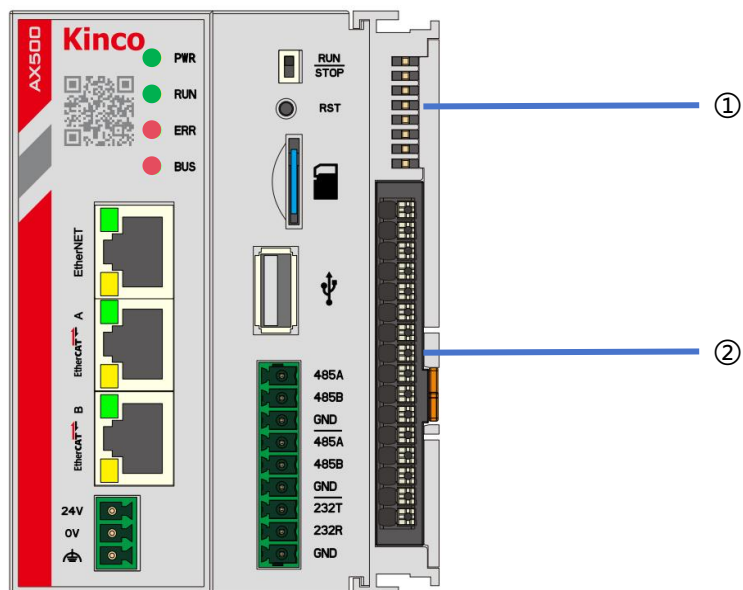

No.	Name	Description	
①	The pin diagram and definition for the coupler indicator lights are as follows:		
	1	9	
	2	10	
	3	11	
	4	12	
	5	13	
	6	14	
7	15		
8	16		
No.	Name	Function	Description
1	24V	Power Indicator	IO Coupler and IO Module Uses Power Supply
2	5V	Power Indicator	IO Coupler and IO Module Local Power Supply
3			
4	LINK	Communication Indicator	FLASHES: Normal Communication Between Modules
5	ERR	Error Indicator	ON: Module Error
6			

7			
8			
9	DI0	Input Indicator	ON: Input Valid
10	DI1	Input Indicator	ON: Input Valid
11	DI2	Input Indicator	ON: Input Valid
12	DI3	Input Indicator	ON: Input Valid
13	DI4	Input Indicator	ON: Input Valid
14	DI5	Input Indicator	ON: Input Valid
15	DI6	Input Indicator	ON: Input Valid
16	DI7	Input Indicator	ON: Input Valid

The electrical pin diagram and pin definitions for the coupler are as follows:

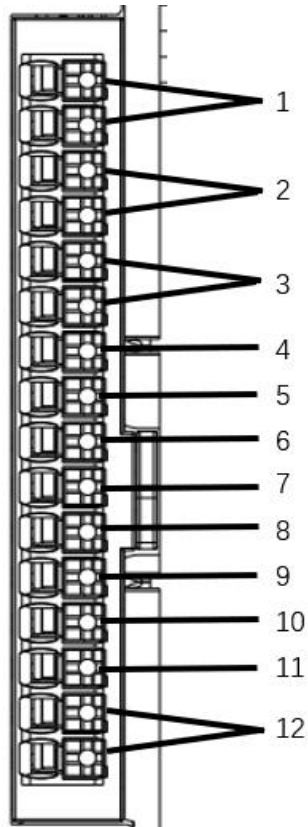

②

No.	Name	Function
1	F_24V	Power Input
2	F_0V	Power Input
3	PE	Ground
4	DI0	DI1
5	DI1	DI2
6	DI2	DI3

	7	DI3	DI4
	8	DI4	DI5
	9	DI6	DI6
	10	DI7	DI7
	11	DI8	DI8
	12	COM	Common Terminal

DI Terminal Instructions

External F_24 and F_0V power supply are required when using the expansion module and the expansion modules. DI supports bipolar wiring.

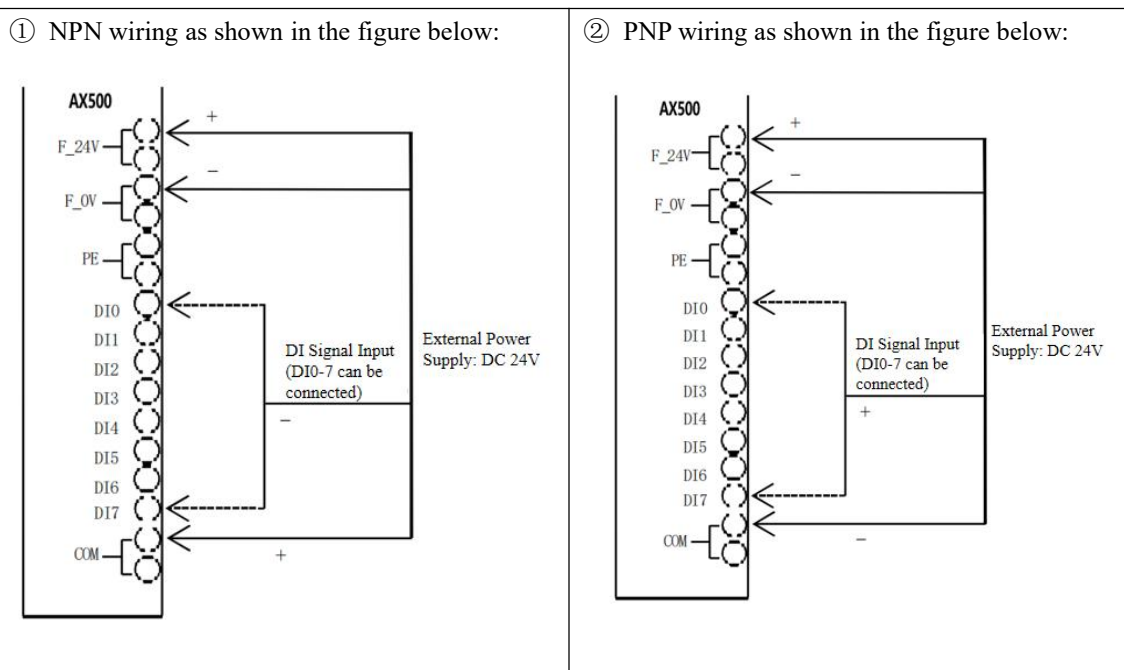

Function Description

1. Status Indicator Function

Name	Status	Description
PWR	Green	ON: Power On
RUN	Green	ON: User Program Startup
ERR	Red	ON: User Program Fault
BUS	Red	ON: Communication Fault

The possible states of the RUN indicator are as follows:

- (1) On when the user program is running; Off when the user program is stopped;
- (2) Flashes rapidly during program downloading; Returns to a steady state after the download is completed;
- (3) Flashes when the Wink button is clicked for device identification.

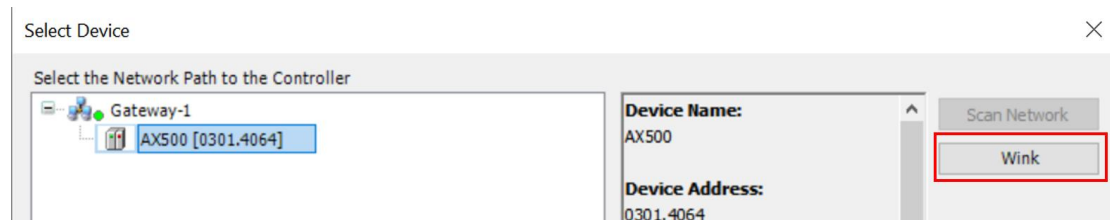

- (4) RUN and ERR indicator flash alternately when no user program is found on the controller;
ERR indicator: On when user program error occurred.
BUS indicator: On when communication error occurred, indicates an abnormality in the device tree status, as illustrated in the diagram below.

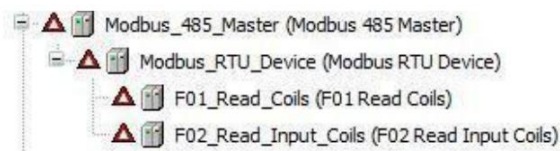

2. User Program Download by USB

- (1) To use a FAT32 formatted USB drive, copy the user program files (Application.app and Application.crc) to the root directory of the USB drive. Insert the USB drive into the controller's USB port, then restart the controller. The program will run automatically. (USB 2.0 support only)

modbus-rtu-485-slave.project - CODESYS

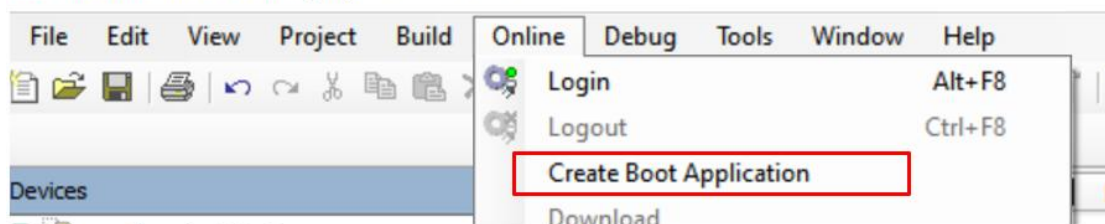

Create boot application file

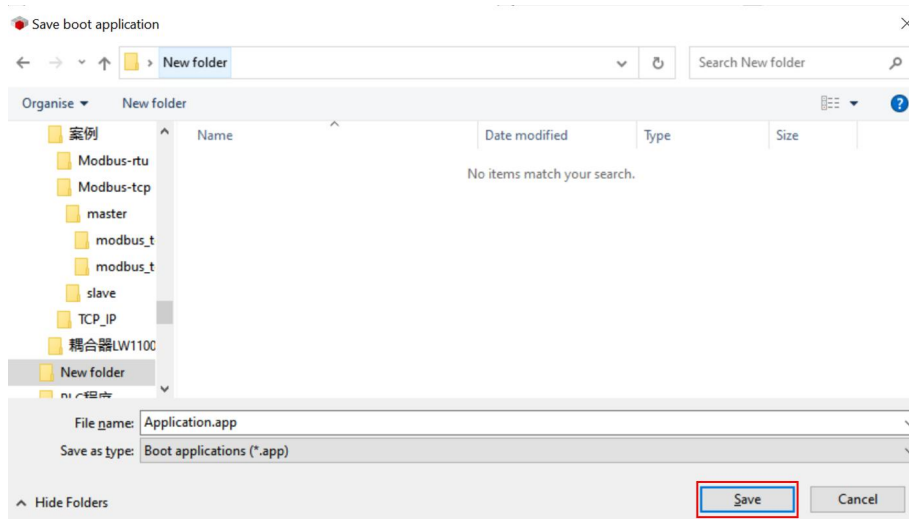

Save boot application file

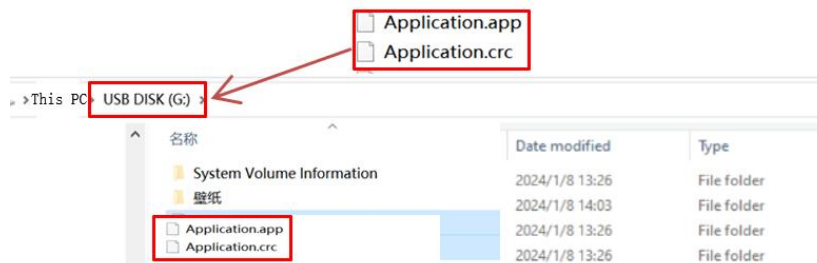

Copy the user program (Application. app and Application. crc) to the root directory of the USB flash disk, then insert the USB flash disk to the USB port of the controller, restart the controller.

(2) Download source code to hard drive of the program - 32MB Max

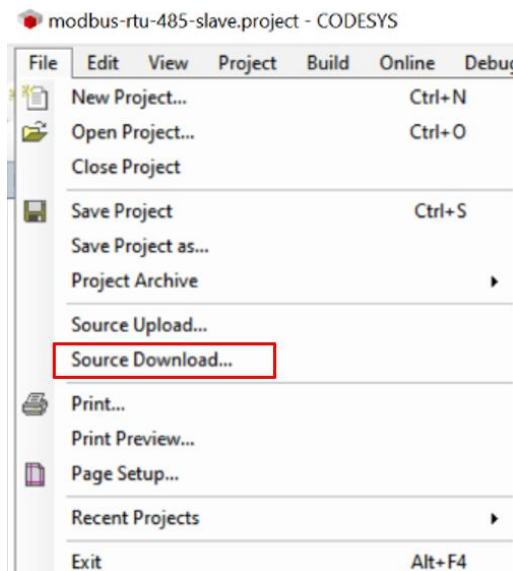

3. Firmware Upgrade

Place the upgrade format firmware package in the root directory, then restart the controller. After a successful upgrade, an “upgradeOK” file will be generated.

(1) Place the firmware package in the root directory, then insert the USB drive into the controller's USB port. Restart the controller, and the upgrade will automatically take place. After a successful upgrade, a file named "upgradeOK" will be generated in the root directory. (USB 2.0 support only)

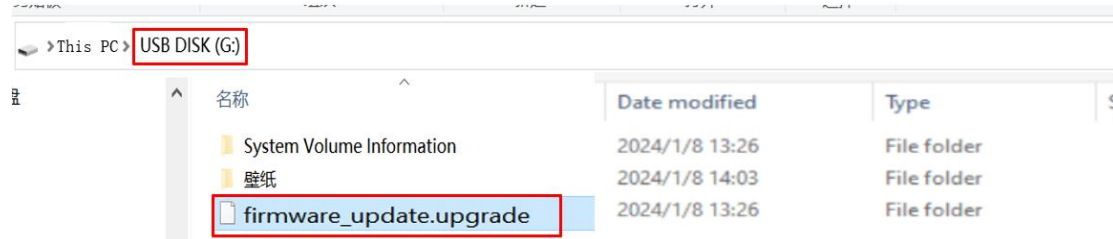

Place the firmware package under the root directory of the USB flash disk and insert the USB flash disk to the USB port of the controller, restart the controller

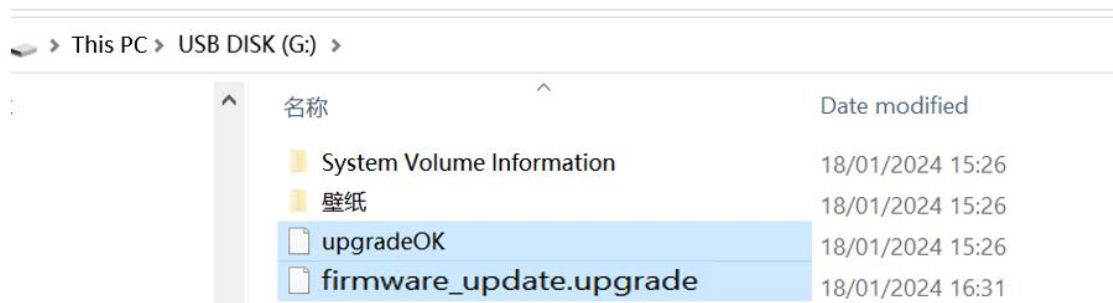

A upgradeOK file appears after the upgrate succeeded

(2) Place the firmware package in the root directory of the controller through CODESYS, restart the controller, and a upgradeOK file will appear after the upgrade success.

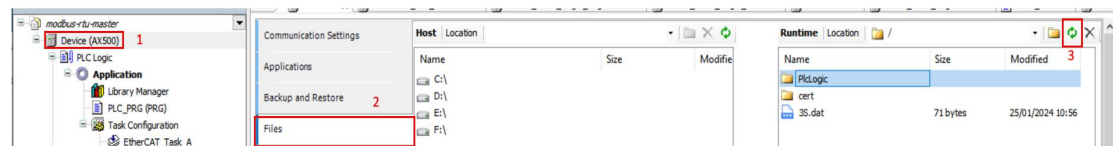

Open the root directory of the controller

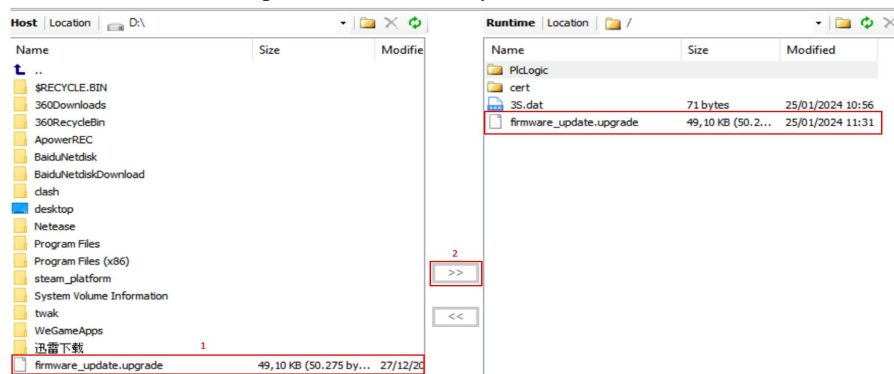

Place the firmware package in the root directory of the controller, restart the controller

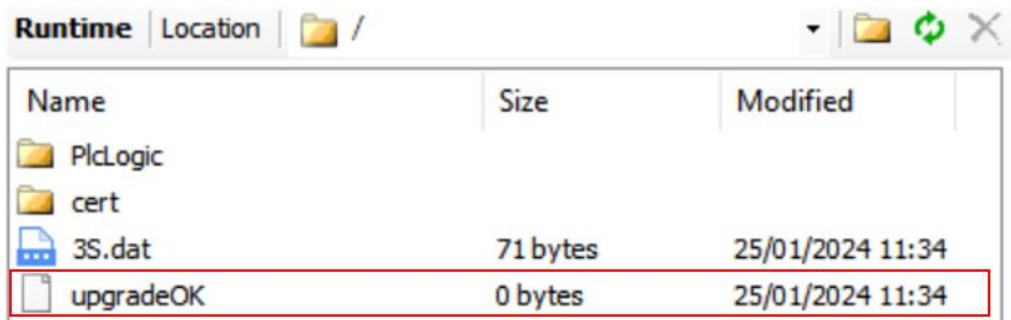

A upgradeOK file appears after the upgrate succeeded

(3) Upgrade the firmware through the software. Place the firmware package under the root directory of the controller. Restart the controller, and a upgradeOK file will appear after the upgrade success.

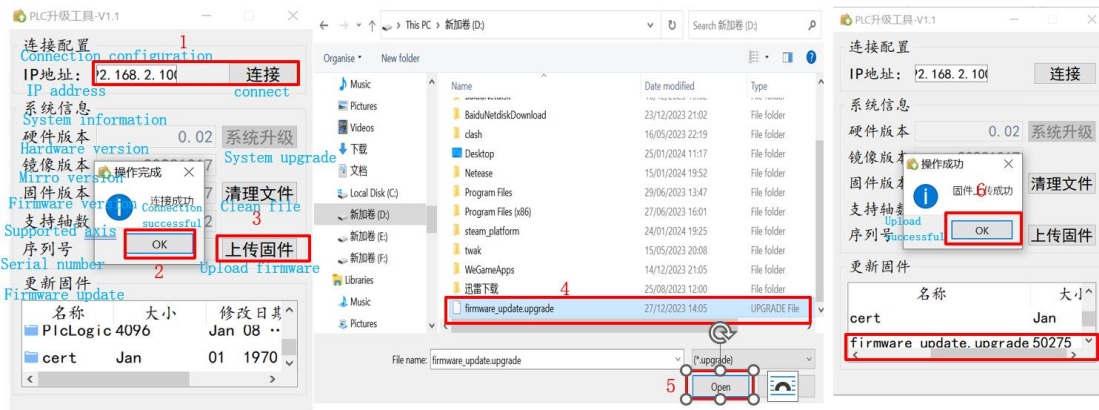

Enter the IP address to connect to the controller. After successful connection, upload the firmware package and restart the controller

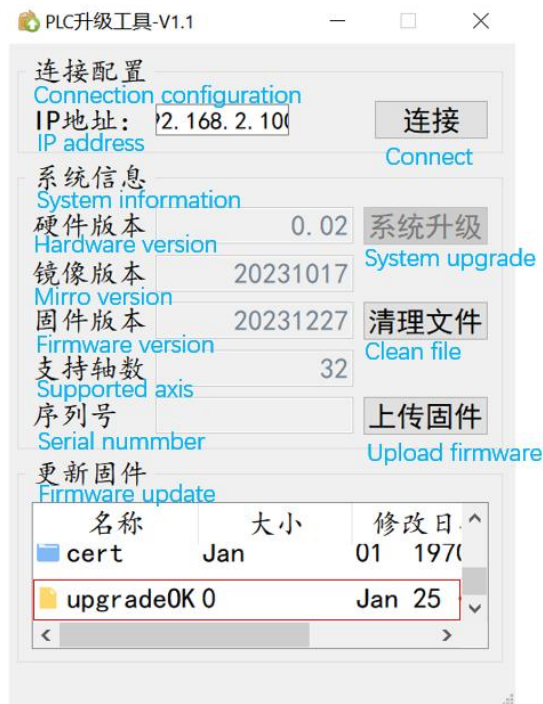

A upgradeOK file appears after the upgrate succeeded

Multi-node Connection

When there are many nodes on the RS485 bus, it is imperative to use a daisy-chain topology. If branch topology is required for connections, the branch length from the bus to each node should be as short as possible, ideally not exceeding 3 meters.

The use of star-type connections is strictly forbidden. A diagram of common RS485 bus topologies is as follows:

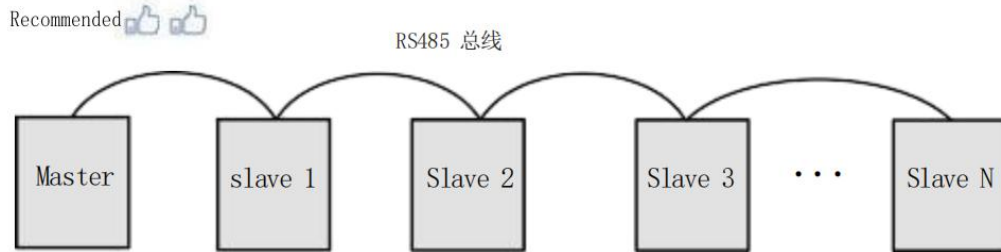

Daisy-chain Connection

RS485 Bus

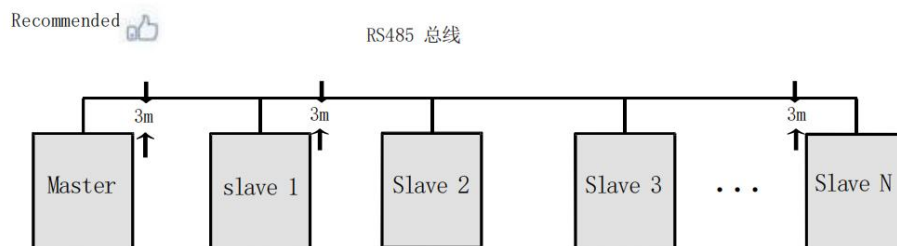

Branch Connection

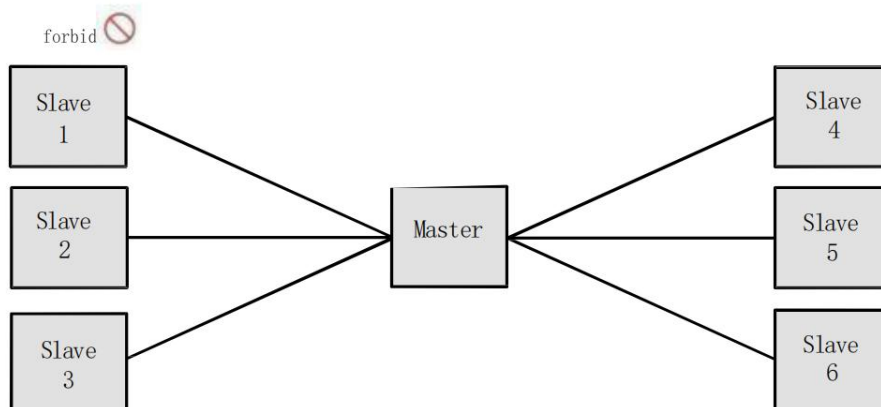

Star-type Connection (Prohibited)

RS485 Bus Wiring

When configuring the RS485 communication interface for the AX500 series programmable controller, ensure the following:

Three Cables: Make sure the on-site RS485 bus includes three cables, namely 485A, 485B, and GND.

Correct Wiring: Check whether the wiring terminals are connected incorrectly or reversed. Ensure that 485A and 485B are not reversed, and GND is correctly grounded.

Use of Shielded Cables: If using shielded cables, ensure that the shield layer is connected to the GND terminal. At any node or midway point, besides connecting the shield layer to the GND at the node, it is prohibited to connect the shield layer to any other location (including the on-site casing, equipment grounding terminal, etc.).

Cable Specifications: For cables with lengths exceeding 3 meters, it is recommended to use AWG26 or thicker cables to reduce cable attenuation. It is advised to always use twisted pair cables to connect 485A and 485B, reducing electromagnetic interference and improving signal quality.

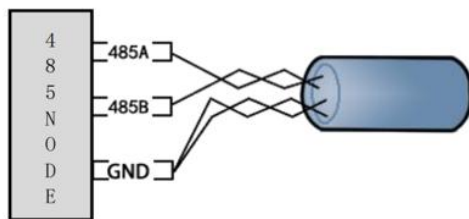

Figure A: Multi-core Unshielded Cable

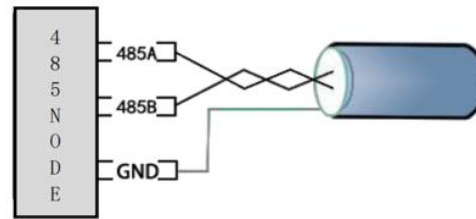

Figure B: Twisted Shielded Cable

RS485 Connection Diagram

- Recommended Cable 1: Multi-core cable with twisted pairs. Use one pair of twisted wires for connecting 485A and 485B, and twist the rest together to form the GND connection.
- Recommended Cable 2: Shielded twisted pair cable. Use the twisted pair for connecting 485A and 485B, and the shield for the GND connection.

RS232 Bus Wiring Description

Description of RS232 Pin is as follows:

RS232
232R
232T
GND

4. Ethernet Connection

The AX500 series controller provides 3 network ports, which are described as follows:

No.	Network Port	Function
1	EtherNET	Support programming protocols, connect to HMI, and communicate via Modbus/TCP.
2	EtherCAT A	EtherCAT master port A
3	EtherCAT B	EtherCAT master port B (Ethernet functionality optional)

With the Ethernet port, the controller can be connected point-to-point with devices such as a computer, HMI, etc. via a single Ethernet cable.

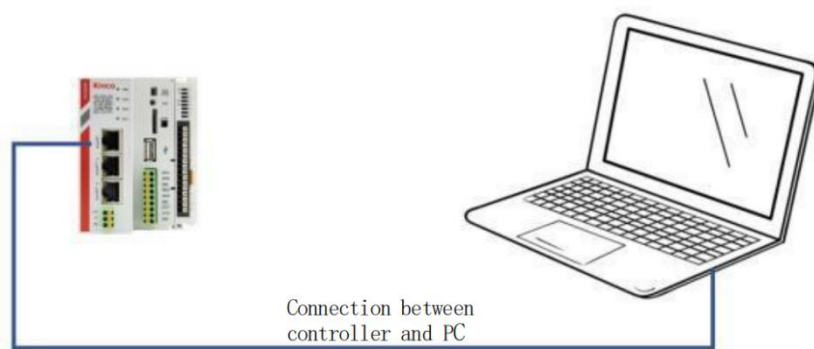

The controller can also be connected to a hub or switch via its Ethernet interface to form a multi-point communication network with other devices.

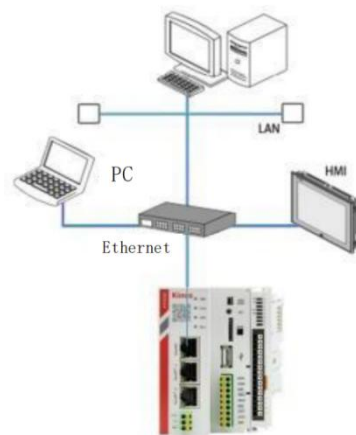

Connection of the CPU module to other devices via a switch

Programming Tool Downloading

Free user programming software of Kinco AX500 series can be downloaded at:

Kinco official website: <http://www.kinco.cn> on the data download page. Users can also download product and application reference materials for the AX series there.

The official CODESYS website: <http://www.codesys.cn/>, with the recommended version: SP 3.5.18.

As Kinco continuously improves its products and materials, it is recommended that users timely update their software and refer to the latest published materials when needed.

Programming Environment and Software Installation

Operating Environment Requirements

Hardware requirements: Recommended 64-bit Windows 7 or Windows 10 operating system; computer RAM of 8GB, and more than 5GB of remaining space on the hard drive or SSD.

It is recommended that the computer's CPU clock speed is above 2GHz, as lower speeds may affect the software's operating speed.

The PC and AX500 controller are connected via a LAN network cable. It is recommended to connect the AX500 through a router to the LAN network. This method allows for longer communication distances and faster interactive communication rates between the PC and AX500, making it more convenient for remote debugging, such as programming and debugging equipment in the workshop from an office. Therefore, a spare LAN port is required in the local network.

Mechanical Design

Dimensions

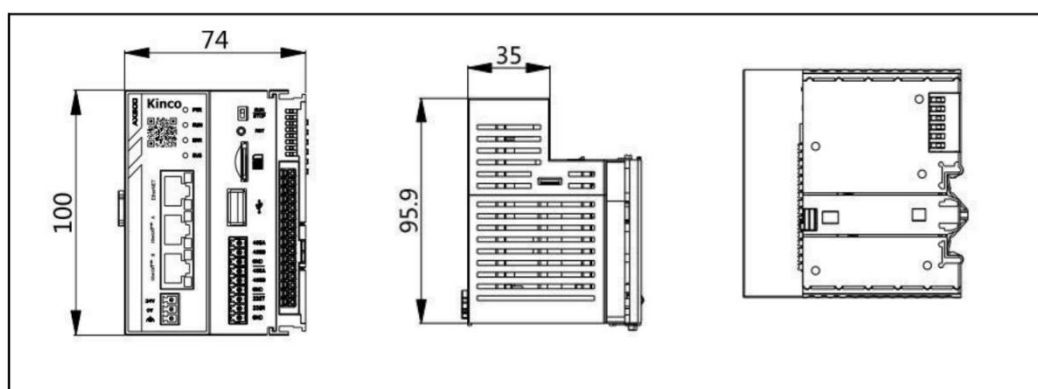

Dimensions of AX500 (unit: mm)

Mounting

Mounting Guide

The AX500 controller adopts a snap-fit installation design, supporting snap-in mounting to meet the installation requirements of different-sized cabinets on-site.

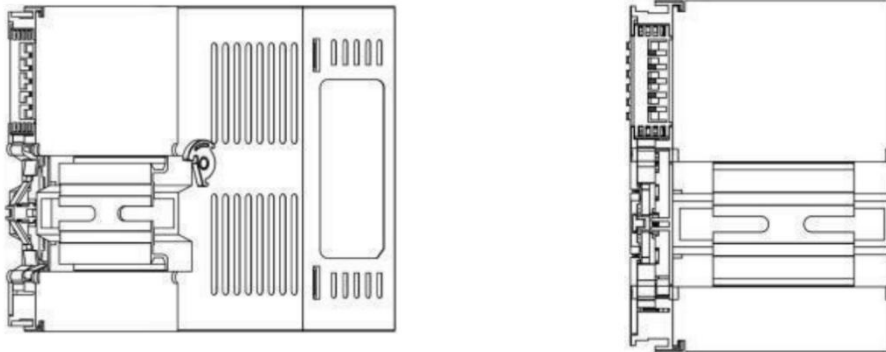

Snap-fit Installation



- ◆ Before installation, please ensure the device is powered off;
- ◆ For specific mounting dimensions, refer to the "Mechanical Design Reference" for the external dimensions;
- ◆ Do not overtighten the device to avoid damaging terminals and other components.

Add Device Packages to CODESYS

It is required to install the device package of the AX500 to the CODESYS package manager at the first operation of AX500. AX500 device package can be downloaded at Kinco official website or Kinco technical support.

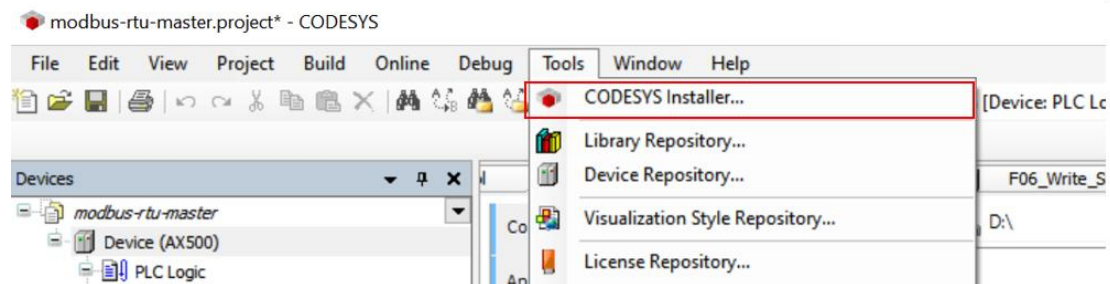

Open the package manager

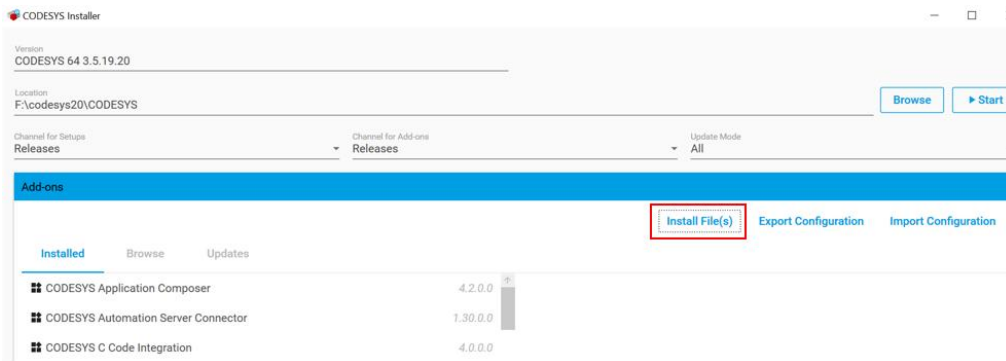

Install the device package

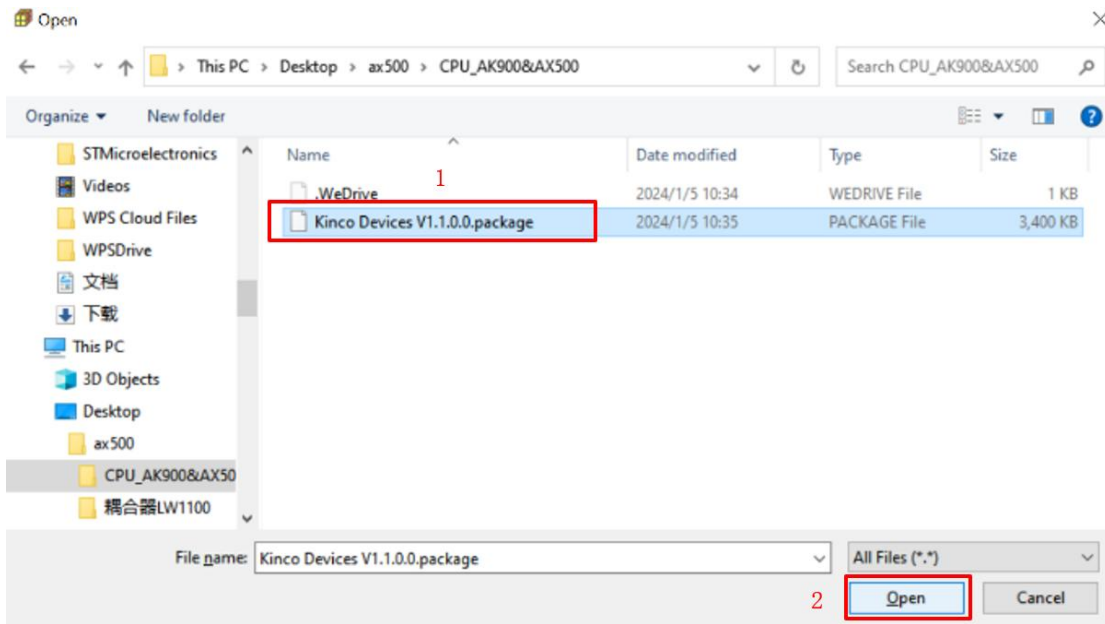

Open the AX500 device package



Allow unsigned and self-signed packages

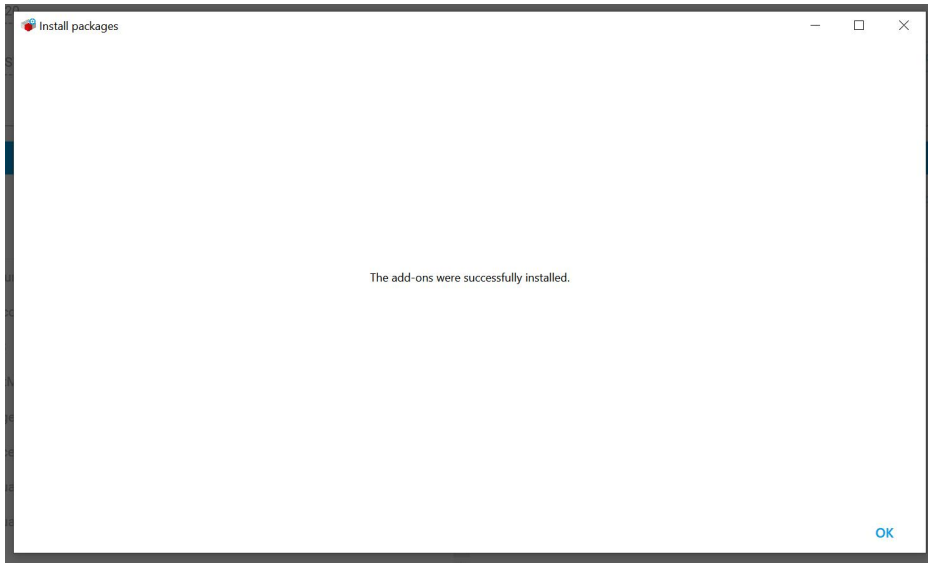

Installation complete

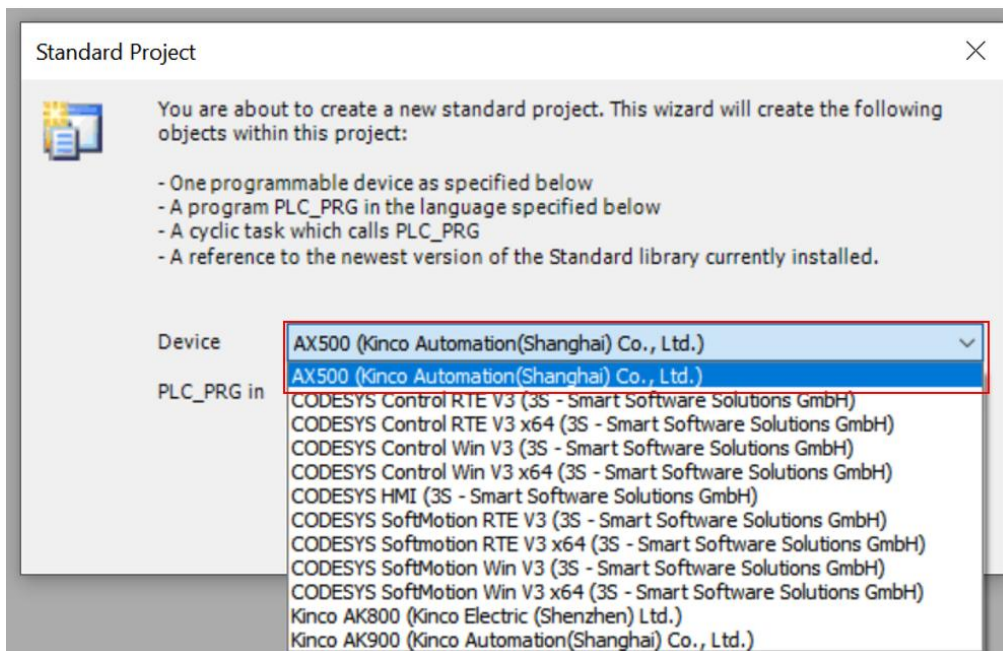

Choose AX500 as the device when creating a new project

Warranty Agreement

This product comes with an eighteen-month warranty period (based on the information on the body's barcode. If there are special agreements, the terms of the purchase contract apply). During the warranty period, if the product malfunctions or is damaged under normal usage as specified in the user manual, our company will provide free repair services.

During the warranty period, repair fees for damages caused by the following reasons will be charged based on the extent of the damage and the difficulty of repair:

- a) Damage caused by incorrect use or unauthorized disassembly, repair, or modification;
- b) Damage caused by fire, flood, abnormal voltage, other disasters, or secondary disasters;
- c) Damage to hardware caused by accidental drops or during transportation while in use;
- d) Damage caused by not following the operation instructions in the user manual provided by our company;
- e) Faults and damages caused by external factors(such as external devices).

When the product malfunctions or is damaged, please accurately and thoroughly fill out the *Product Warranty Card*.

Repair costs will be assessed based on the extent of the damage. Please consult our after-sales service department for detailed charges.

The Product Warranty Card is generally not reissued. Please keep it safe and present it to the repair personnel during the warranty claim.

If you encounter any issues during the service process, please contact our agents or our company promptly.

Purchasing this product implies acceptance of this warranty agreement. Kinco reserves the right to interpret this agreement.

Product Warranty Card

Customer Information	Company Address:	
	Company Name:	Contact:
	Postal Code:	Contact Phone Number:
Product Information	Product Model:	
	Barcode (Barcode Sticker Area):	
	Agent's Name:	
Repair Information	(Time and Explanation):	
	Service Personnel's Name:	